



ITM. / ART. 1902314



Create amazing spaces™



MANUAL

ARTISAN™ 97

USER MANUAL | 조립 설명서

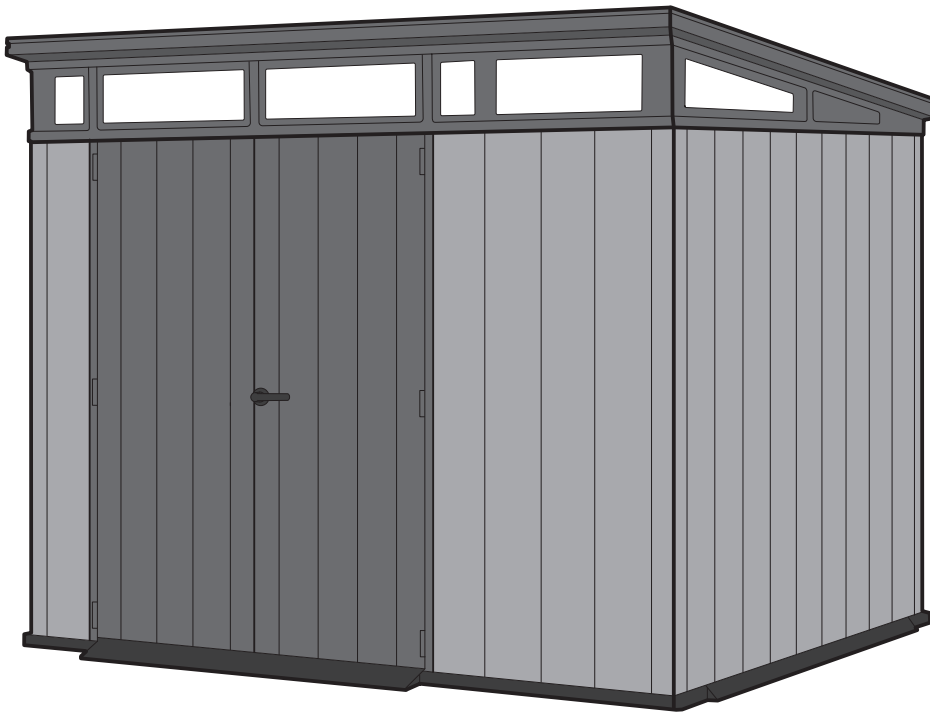

IMPORTANT | 중요

RETAIN FOR FUTURE REFERENCE: READ CAREFULLY

조립 설명서를 보관하시고 주의 깊게 읽어주십시오.

For outdoor use only. Not for commercial use | 실외용. 상업적 용도가 아님.

SKU: 17204256

고객 센터
 TEL.031-767-2492
 FAX.031-767-2492
 E-mail.info@keter.co.kr

5008910 A-1593



SITE PREPARATION | 장소 준비

Level the ground surface | 땅 고르기

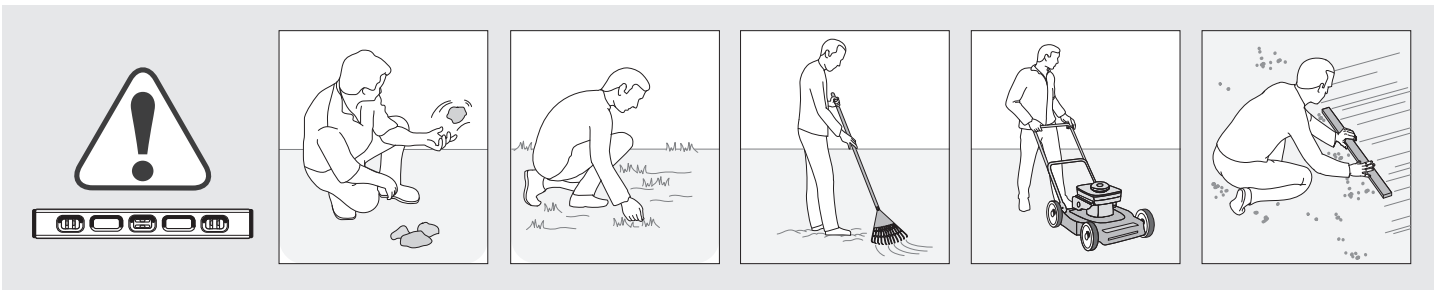

Recommendation: Construct a wooden or concrete base as a foundation | 권장사항: 데크나 콘크리트 바닥을 권장합니다.

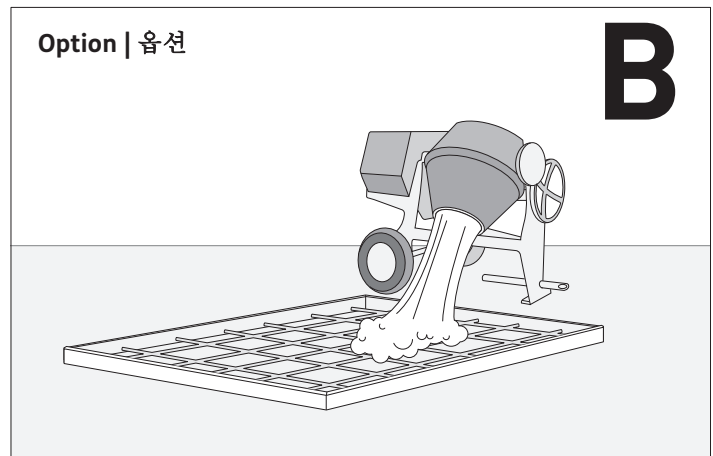
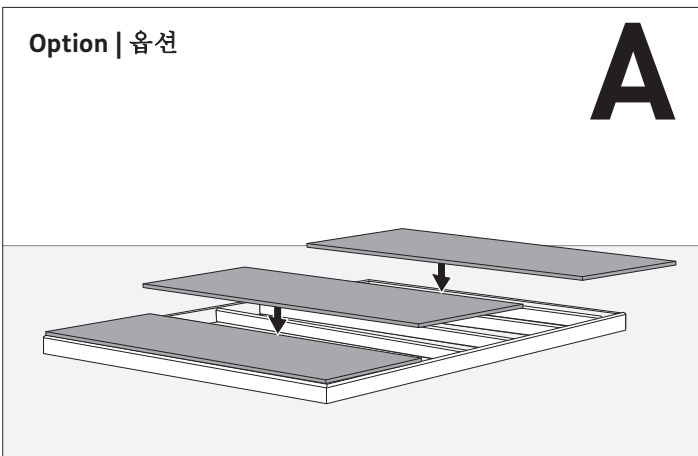

For external access during assembly, make sure to leave enough room around the outside of the shed assembly site.

조립시에 외부 작업이 필요하므로 충분한 공간을 마련하고 작업하시기 바랍니다.

External floor measurements are: | 외부 바닥 치수

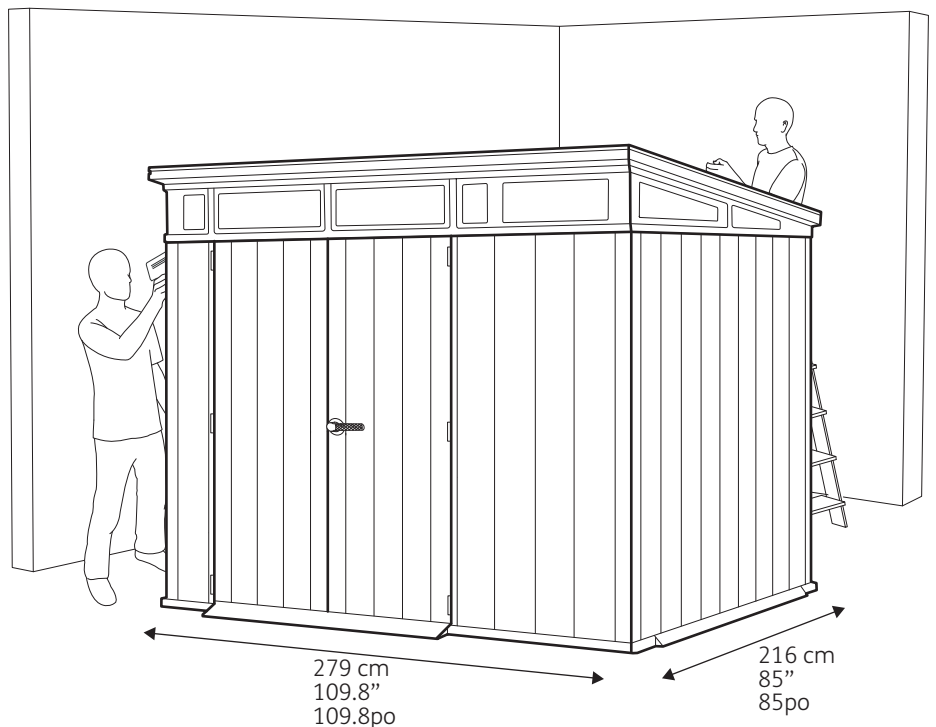



BEFORE STARTING ASSEMBLY | 조립을 시작하기 전에 확인할 내용

Read the care and safety guidelines at the end of this manual | Check to ensure that there are no missing or damaged parts BEFORE starting or arranging assembly | Remove all parts from the package(s) and spread them out on a clean work surface | Review all assembly instructions | Assemble all the parts according to the directions in this manual. Do not skip any steps.

뒤쪽에 있는 조립, 관리 및 안전에 관한 주의사항을 읽어주십시오 | 시작하기 전에 누락되거나 손상된 부품이 없는지 확인하십시오 | 모든 부품을 포장지에서 제거하고 깨끗한 작업 표면에 펼쳐 놓으십시오 | 조립 설명서 전체 내용을 확인해보십시오 | 반드시 조립 설명서대로 조립하시고 어떤 단계도 건너뛰지 마십시오.

REQUIRED TOOLS | 필요한 도구



ASSEMBLY REQUIRES TWO PEOPLE | 2명 이상의 성인이 조립하시길 바랍니다.





SHED PARTS | 창고 부품

Remove all parts from the package(s) and spread them out on a clean work surface. Code letters are imprinted on each part for easy identification | 모든 부품을 포장 박스에서 꺼내 깨끗한 바닥에 펼쳐주시기 바랍니다. | 부품 번호는 각 부품에 표시되어 있습니다.

FLOOR PARTS | 바닥 부품

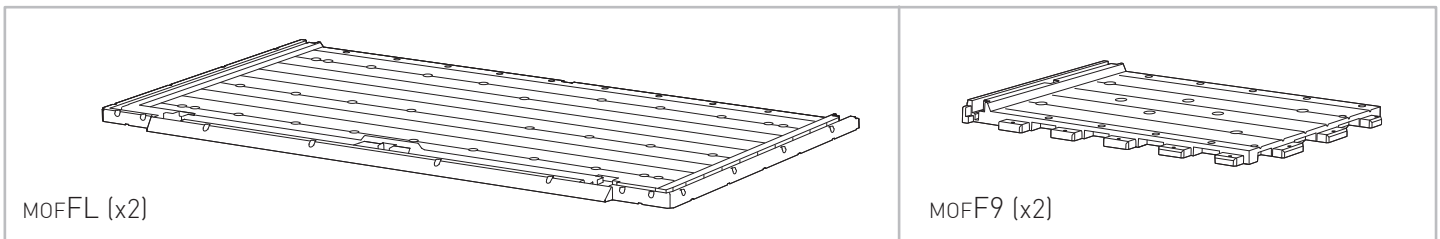

WALL PARTS | 벽 부품

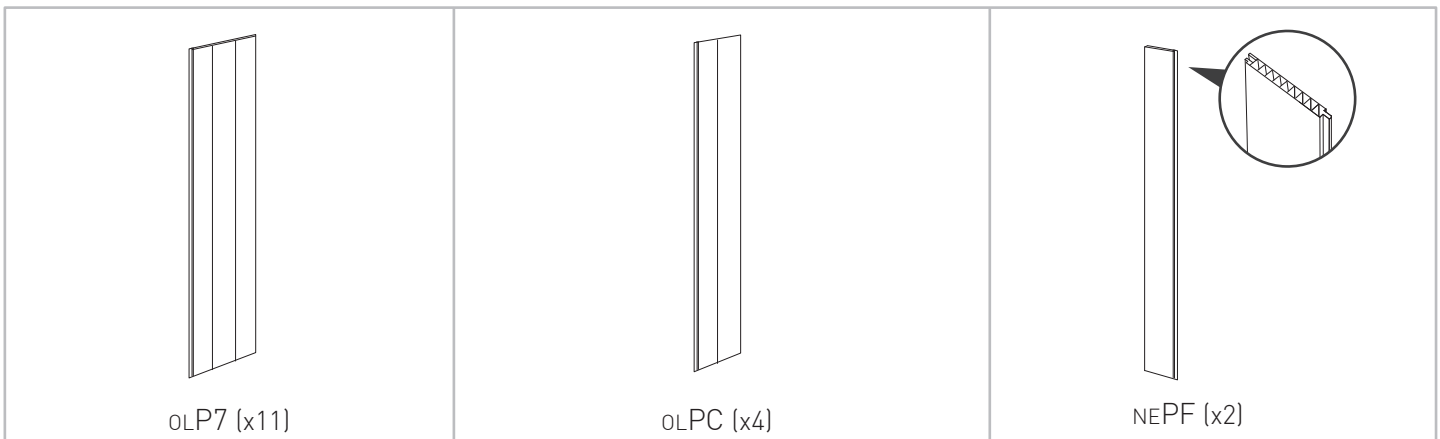

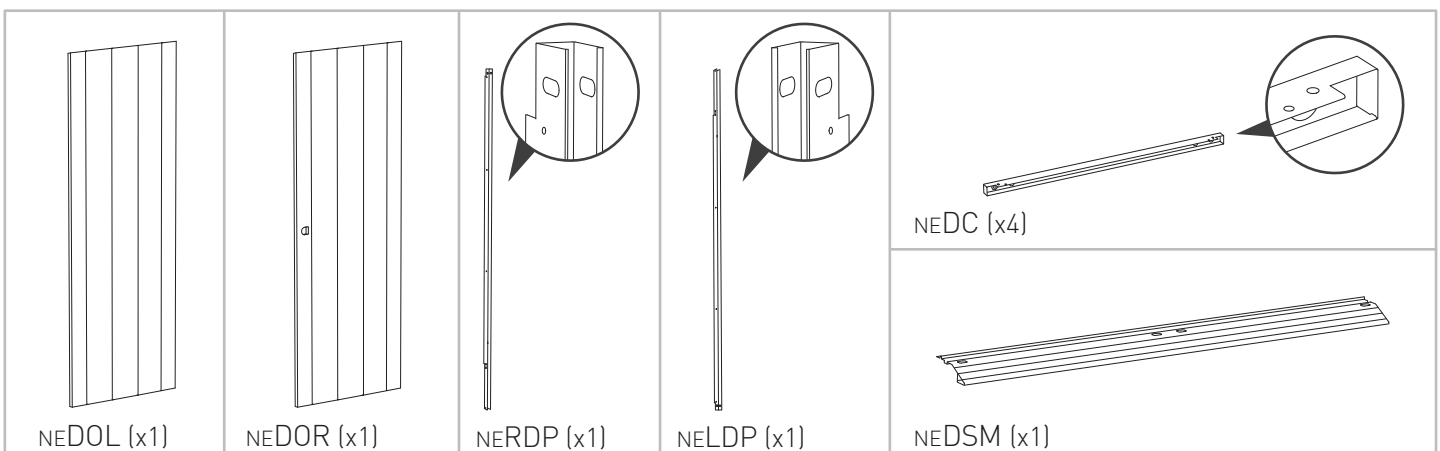

DOOR PARTS | 문 부품







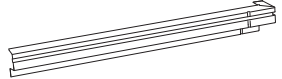
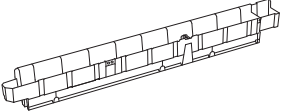
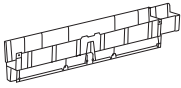
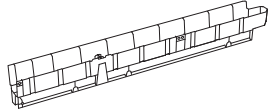
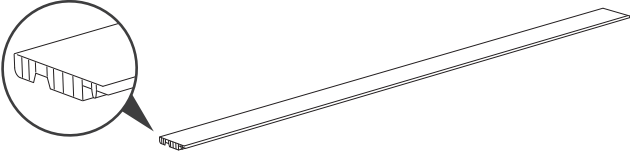
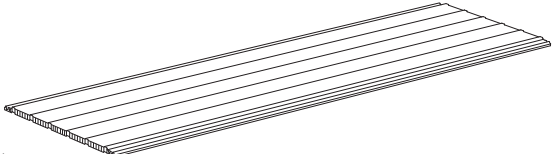

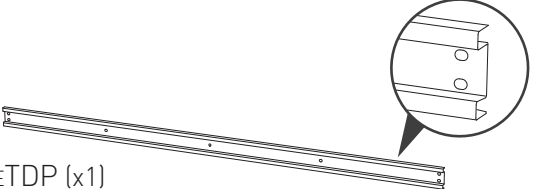
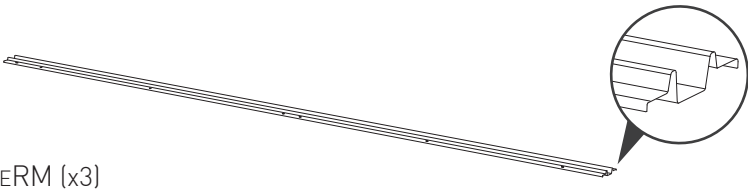
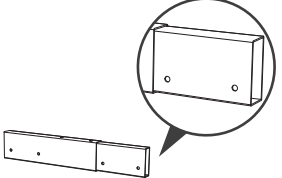
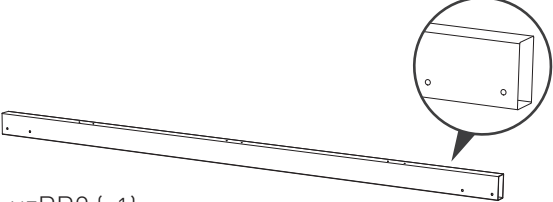
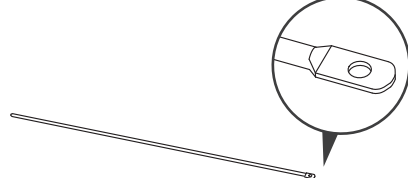

ROOF PARTS | 지붕 부품

 NELC (x1)	 NECE (x1)	 NERC (x1)
 NELD (x1)	 NEDE (x1)	 NERD (x1)
 NEPRE (x2)		 NEPR (x4)

METAL PARTS | 금속 부품

 NETDP (x1)		 NERM (x3)			
 NEBC9 (x2)	 NERB9 (x1)		 NEMB (x2)		
 NEDSO (x2)	 NEDSI (x1)	 NEDSW (x1)	 NEFFM (x1)	 NEBPM (x1)	 NESM9 (x2)



WINDOW PARTS | 창문 부품

NEFF (x1)	NEFE (x1)	NEBLT (x1)	NELT (x1)
NEGR (x2)	NEGE (x1)	NERT (x1)	NEBRT (x1)
NEGT (x2)			

SMALL PARTS | 소형 부품

NEDMC (x8)	NEDH (x6)	KP (x14)	NEPL	NERA (x3)	NEDS (x1)
NUHG (x2)	NUHH (x2)	NUHB (x1)	NUHA (x1)	NUHC (x1)	NUHF (x2)
NUHD (x1)	NUHE (x1)	NEDPC (x2)	NE9C (x2)	NERK (x4)	NEMRC (x1)

SCREWS | 나사

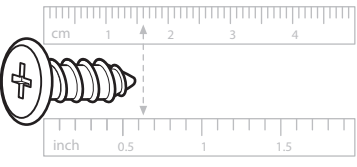
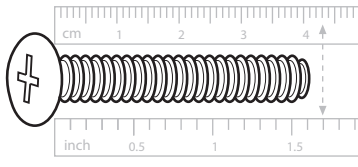
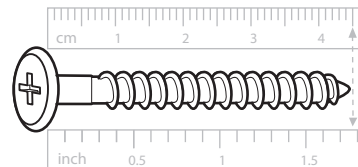
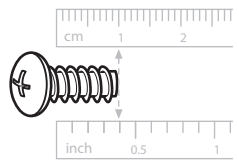
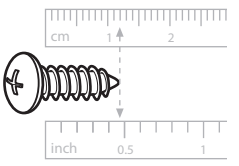
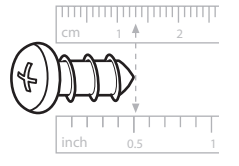
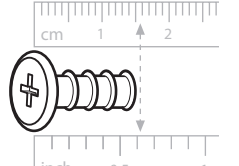
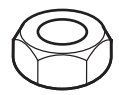
 <p>sc15 (x247) 16 mm / 0.63"</p>	 <p>sc8 (x13) 43 mm / 1.69"</p>	 <p>s45b (x32) 45 mm / 1.77"</p>		
 <p>sf13 (x16) 10 mm / 0.39"</p>	 <p>s13b (x91) 12 mm / 0.47"</p>	 <p>scw1 (x38) 12.7 mm / 0.5"</p>	 <p>sc7t (x12) 16 mm / 0.63"</p>	 <p>scn8 (x13)</p>

Packaging may contain some additional small parts for use as spare parts | 예비 부품이 포함되어 있을 수 있습니다.

NOTE: Due to variations in production, the actual assembled size may vary slightly from the specified dimensions.

참고: 제작 특성상 명시된 사이즈와 실제 사이즈는 조금 다를 수 있습니다.



FLOOR ASSEMBLY | 바닥 조립

1

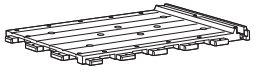

MOFF9 (x2)

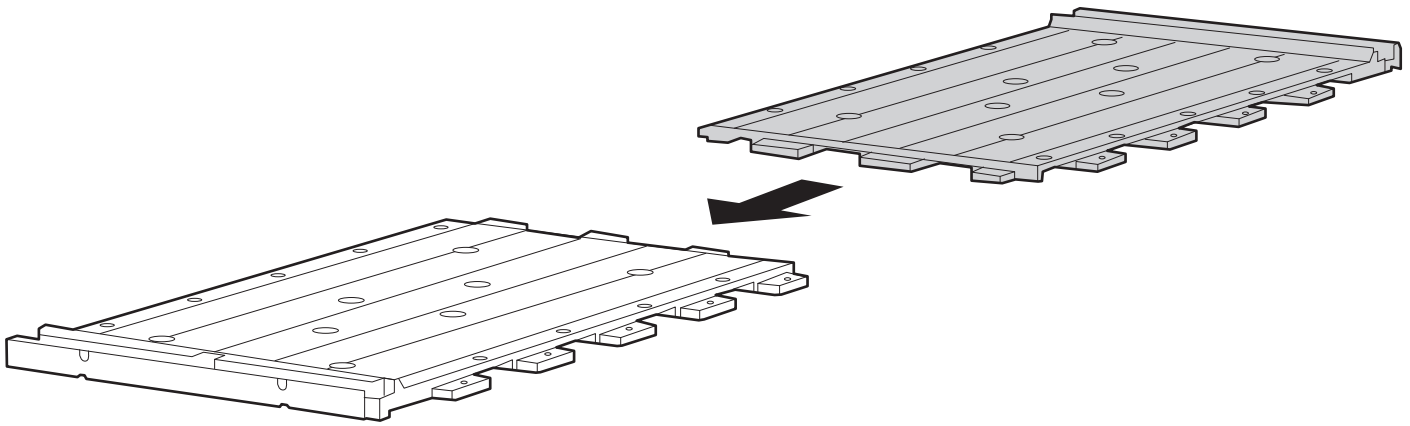

2



sc15 (x4)

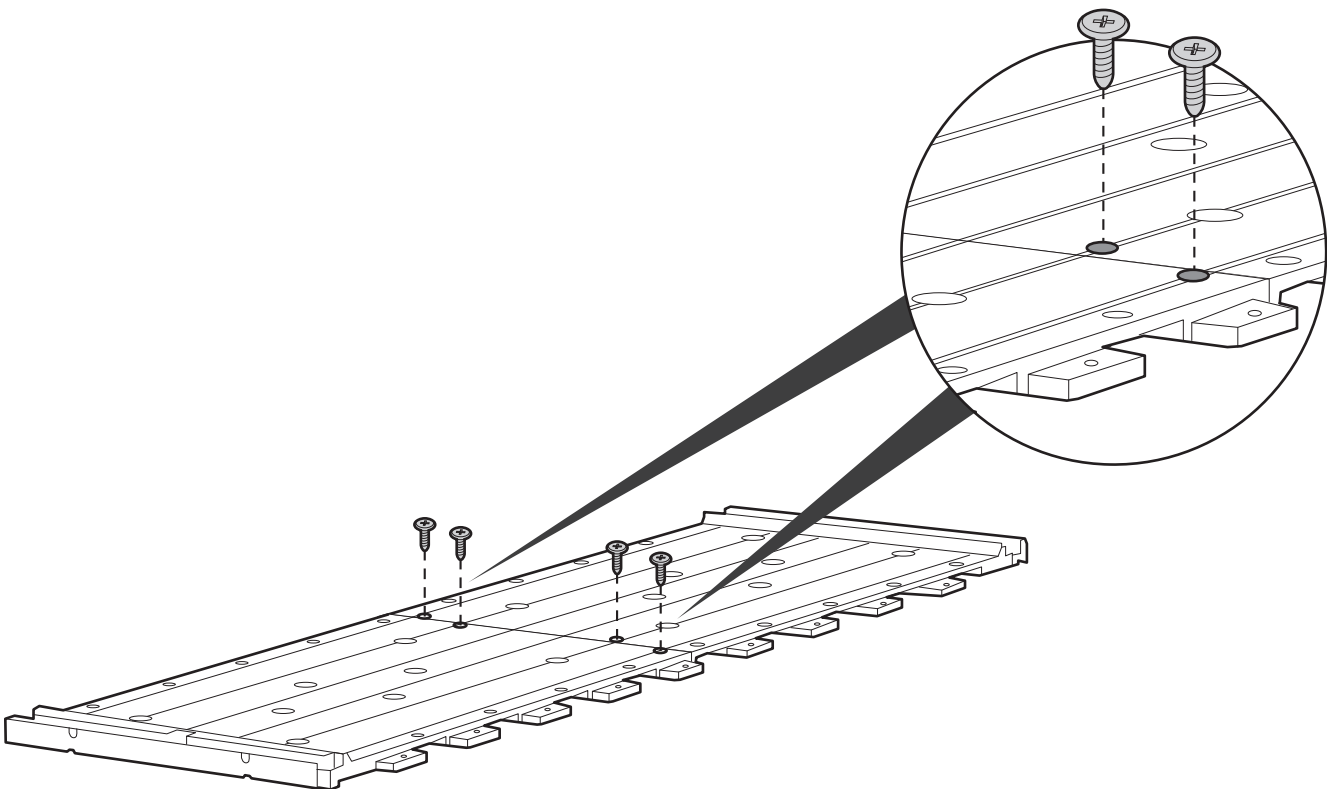



3

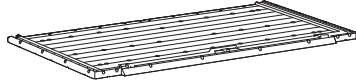
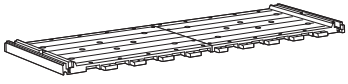

MOFFL (x2)

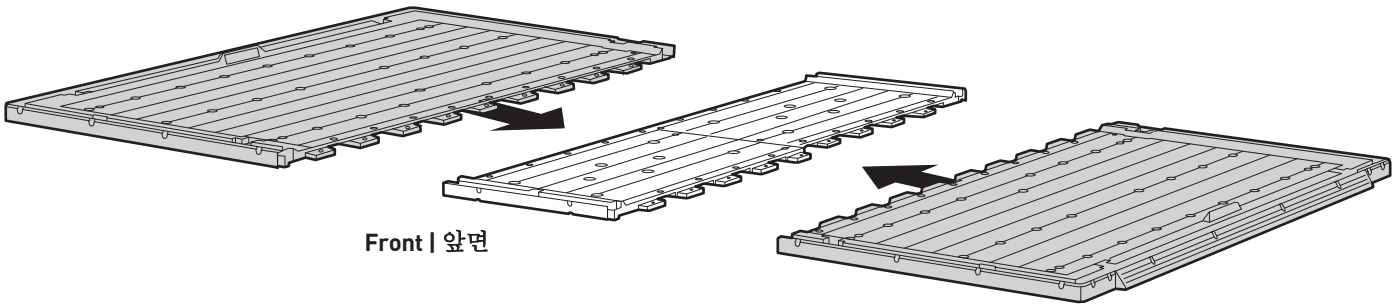

4

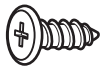

sc15 (x36)

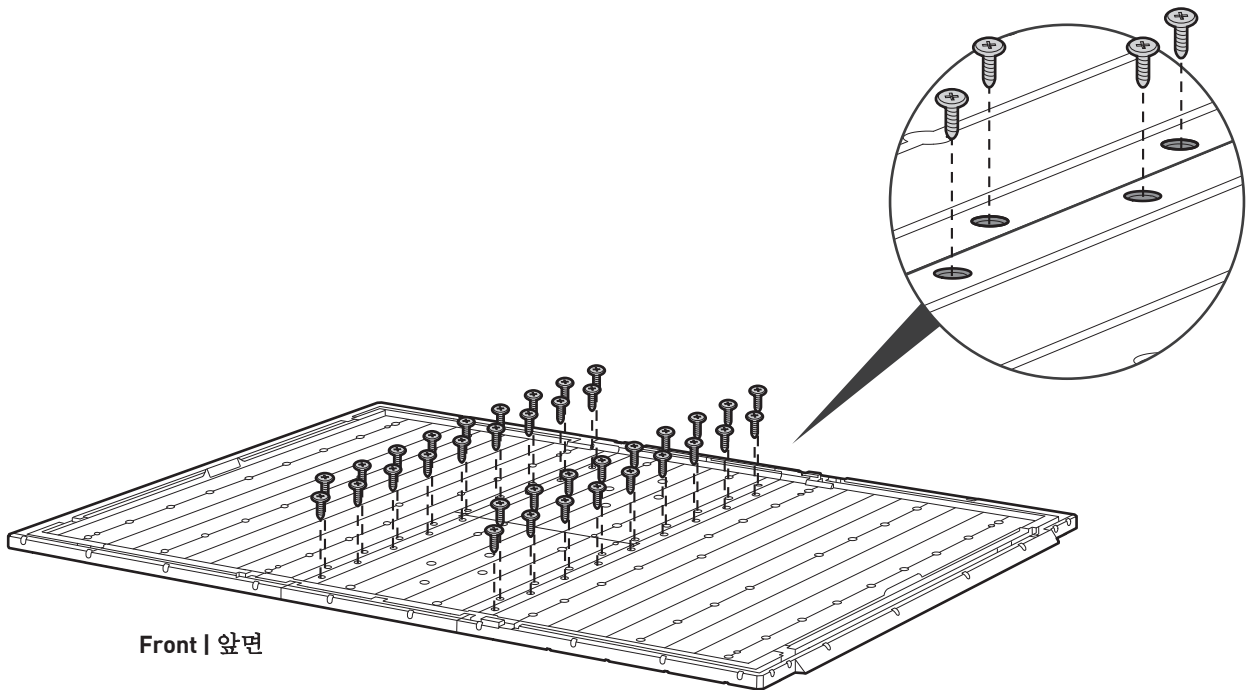

WALL ASSEMBLY | 벽 조립

5

oLPC (x1)

oLP7 (x1)

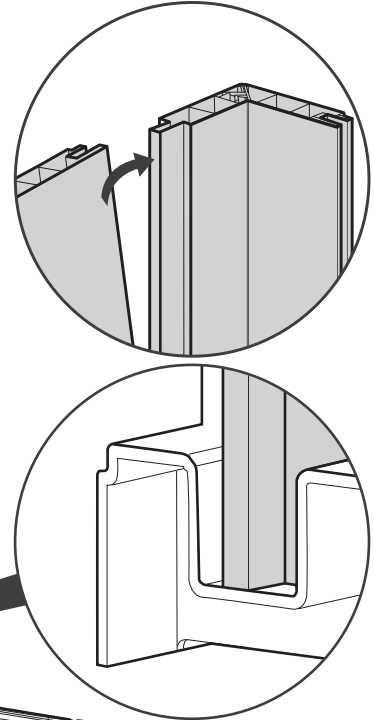
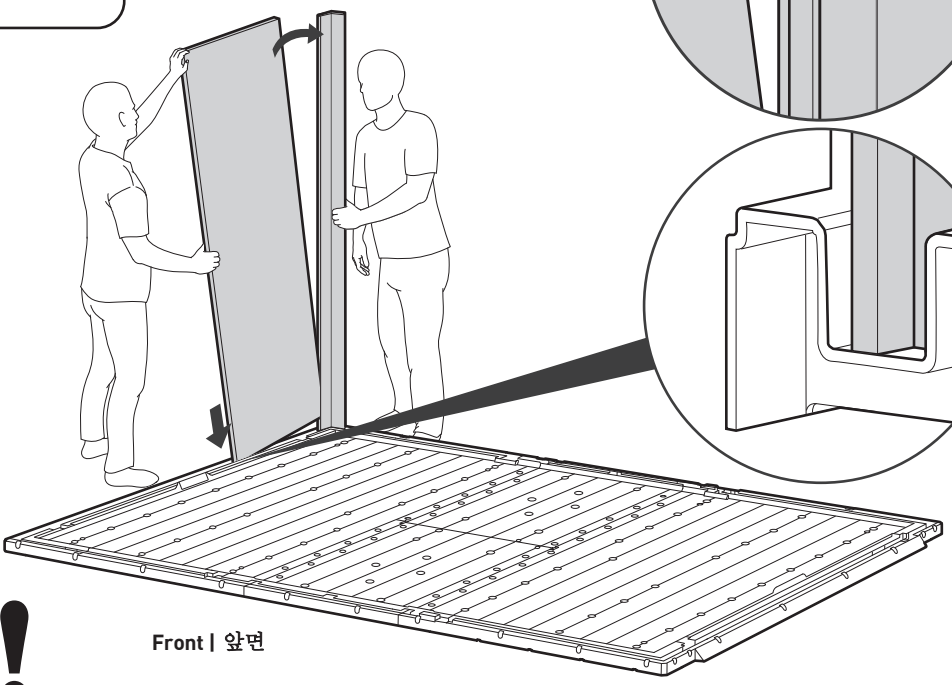
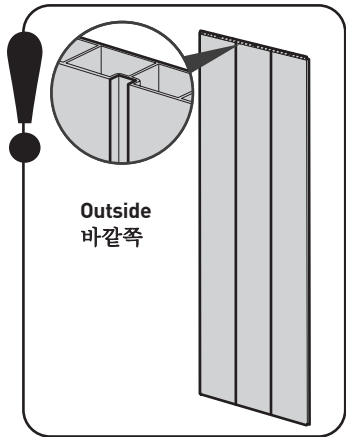
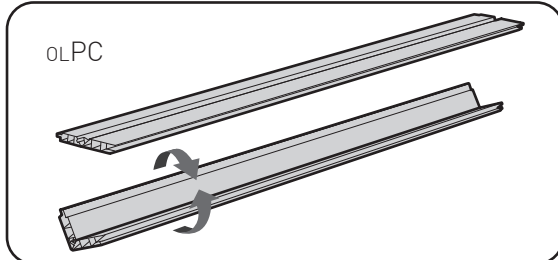

6

KP (x1)

s13b (x1)

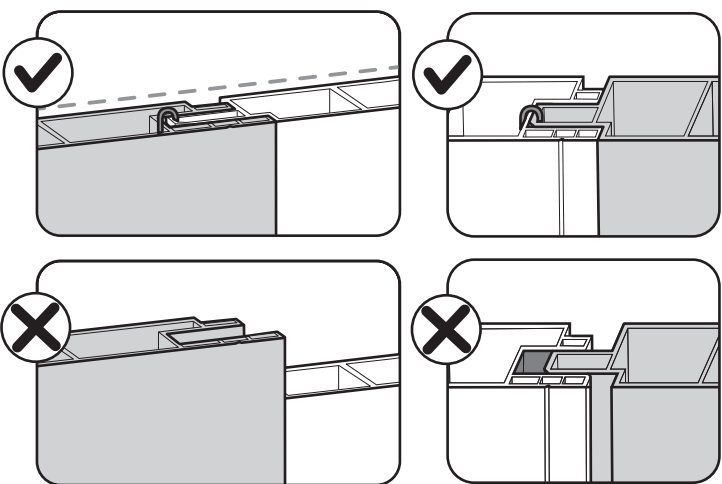
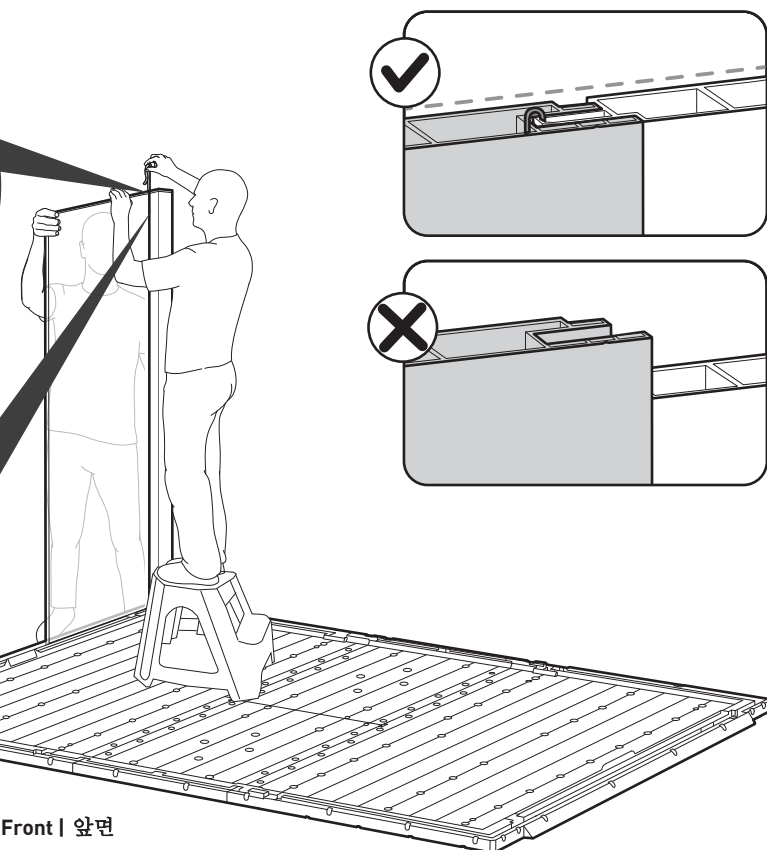
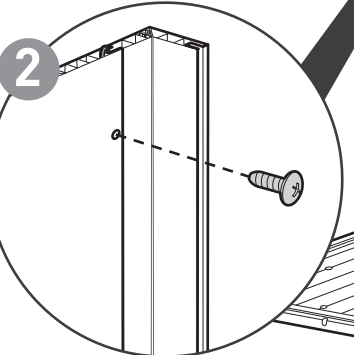
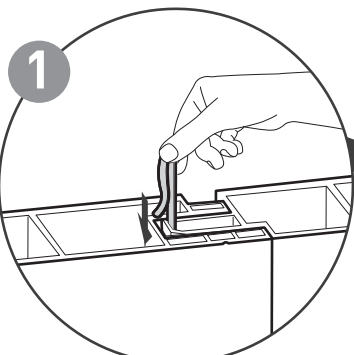



7



oLP7 (x1)

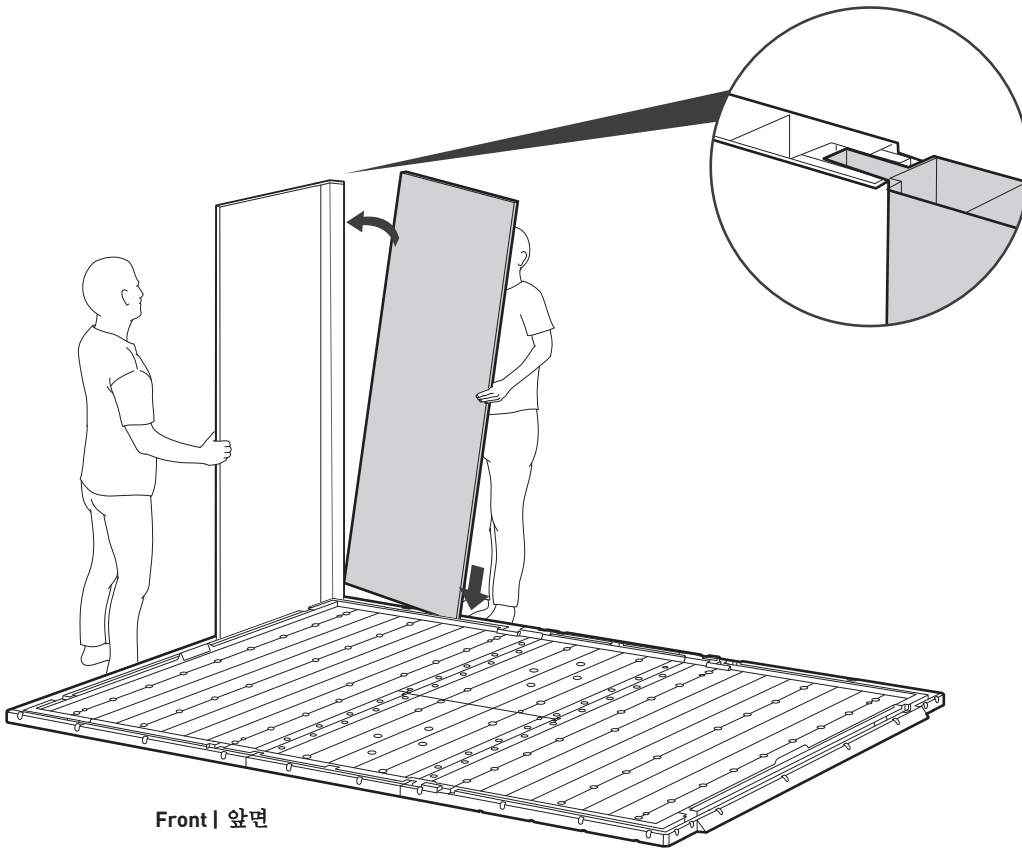

8



KP (x1)



s13b (x1)

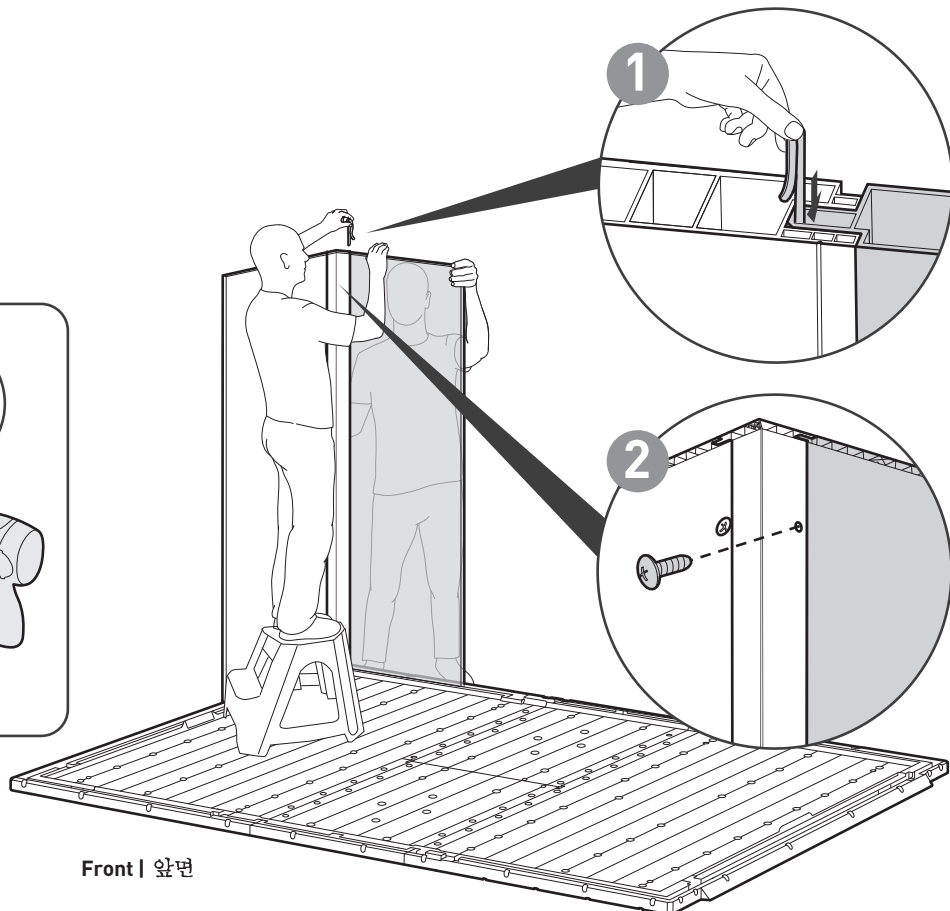
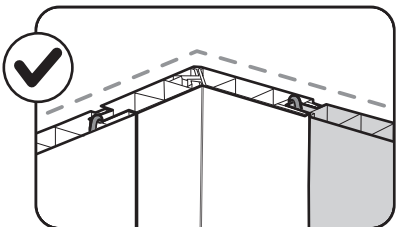



9



oLP7 (x3)



KP (x3)

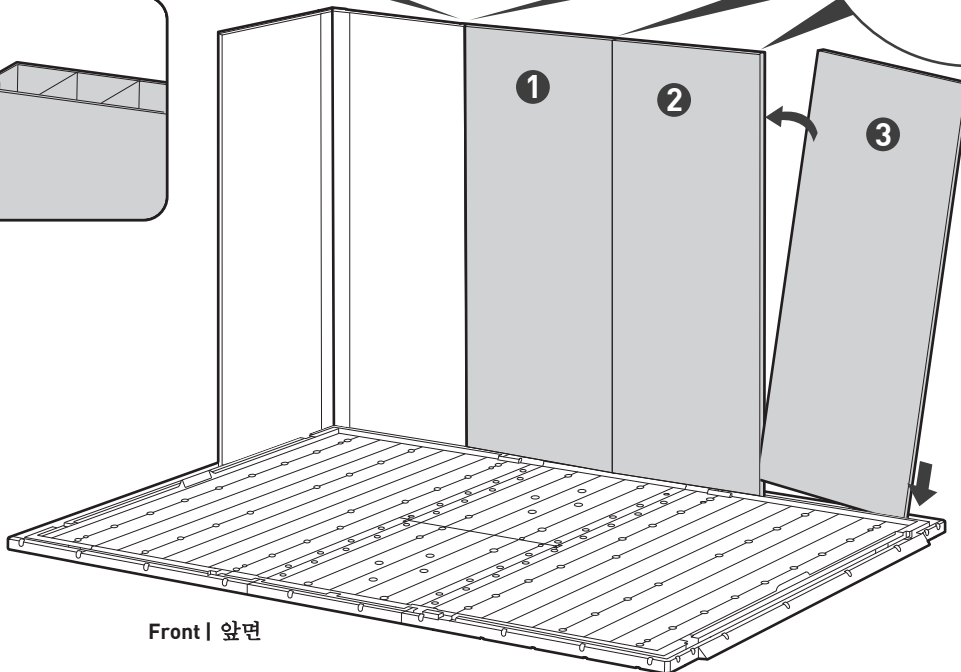
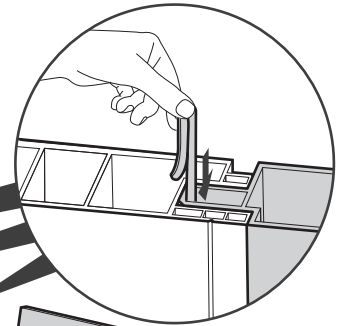
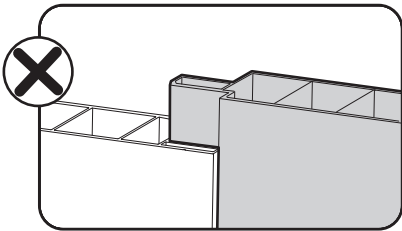
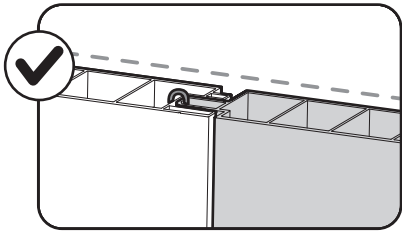

Front | 앞면

10



oLPC (x1)



KP (x1)



s13b (x1)

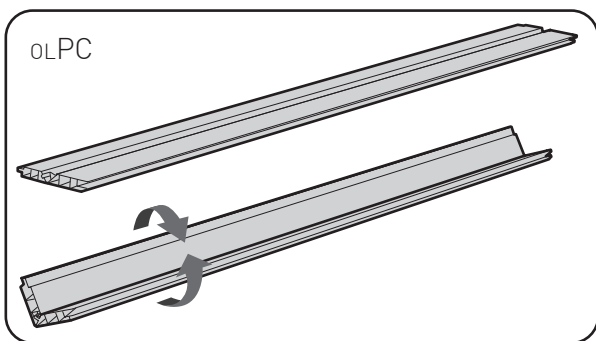

oLPC

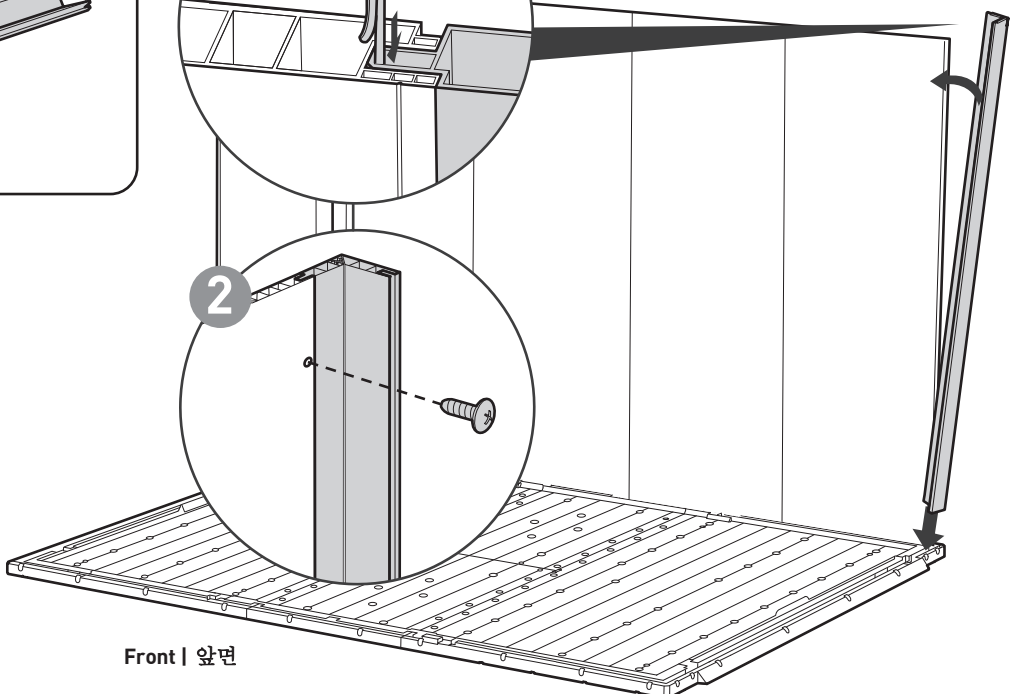
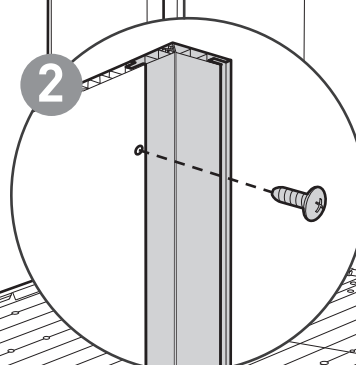
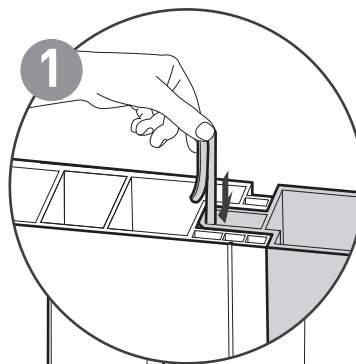
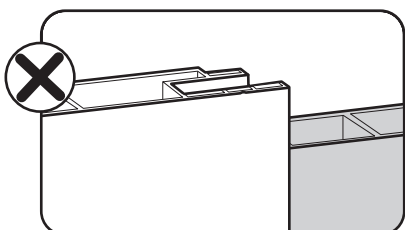
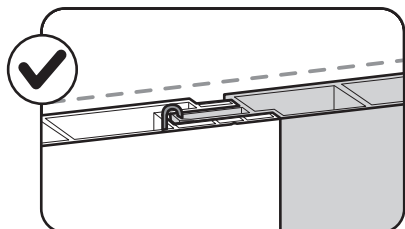

Front | 앞면





11



oLP7 (x1)



KP (x1)

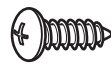

s13b (x1)

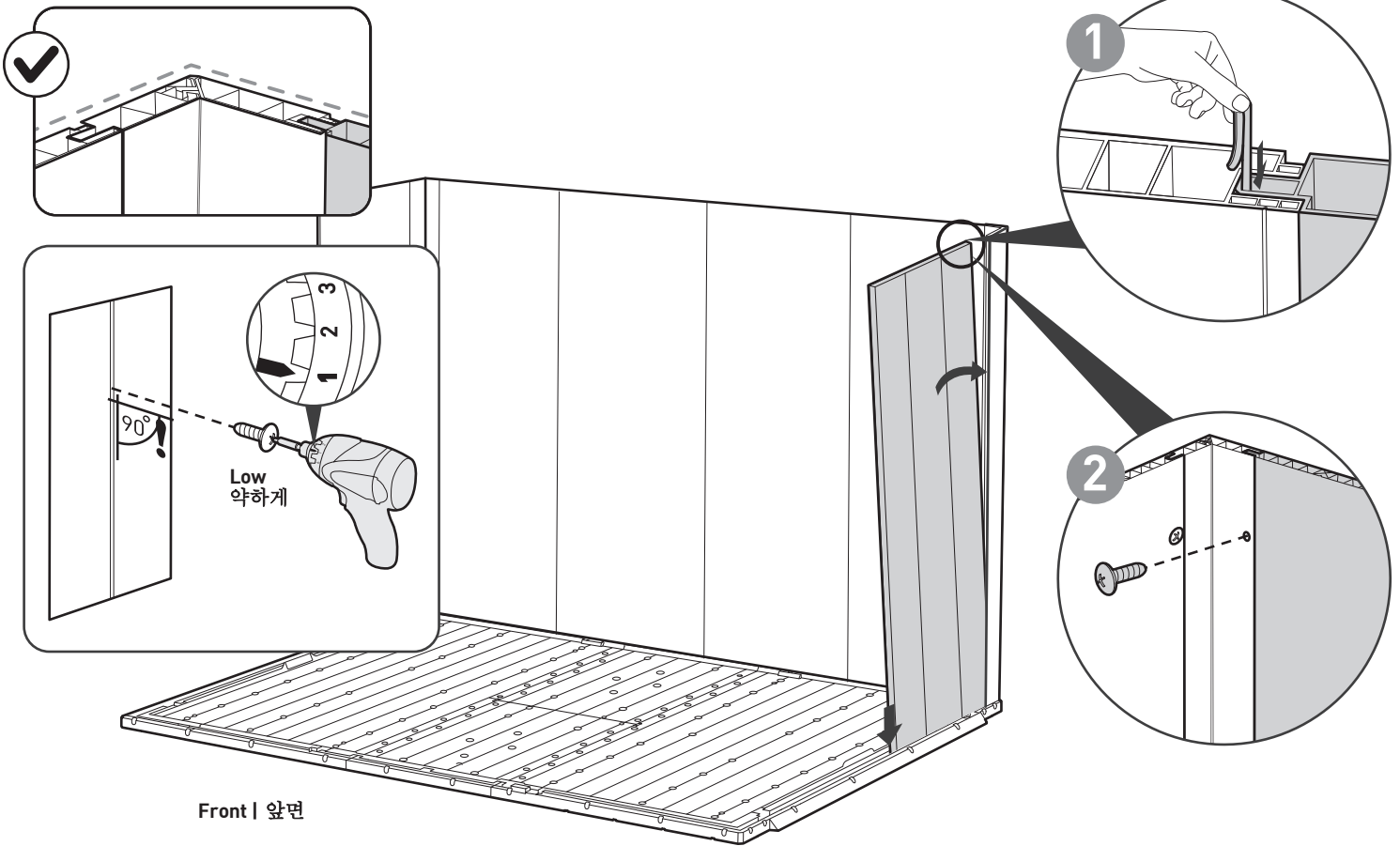

12



oLP7 (x2)



KP (x2)

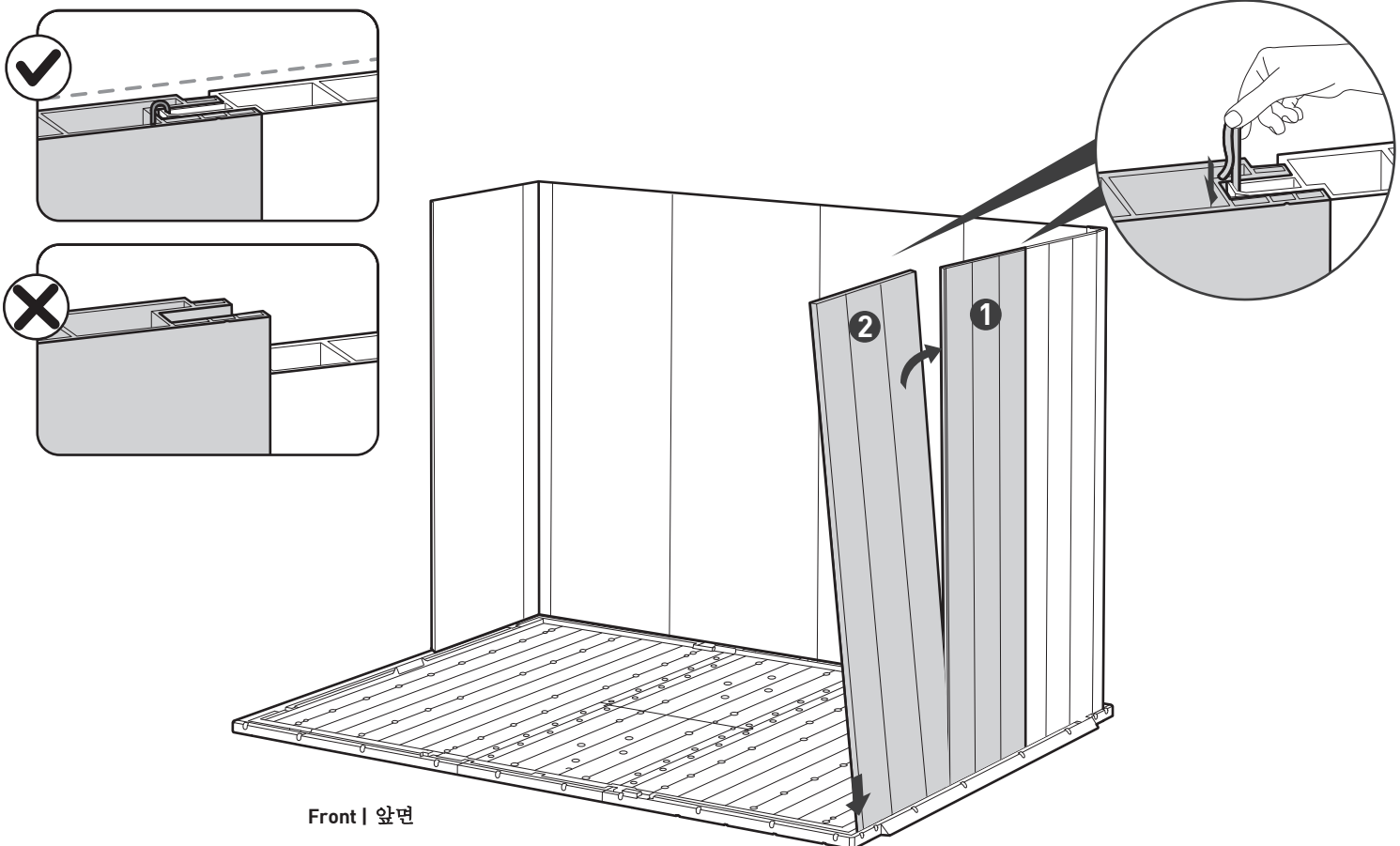



13

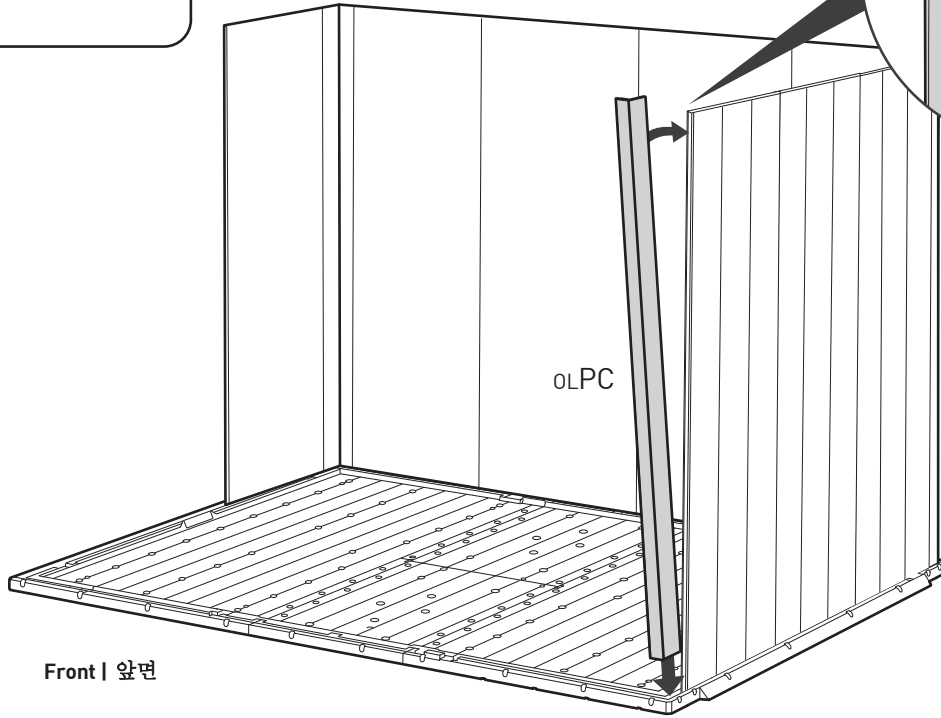
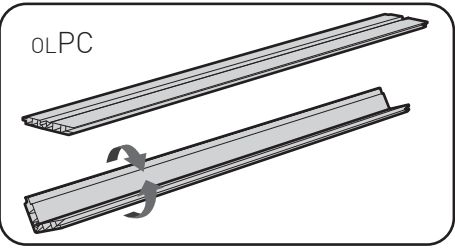

14

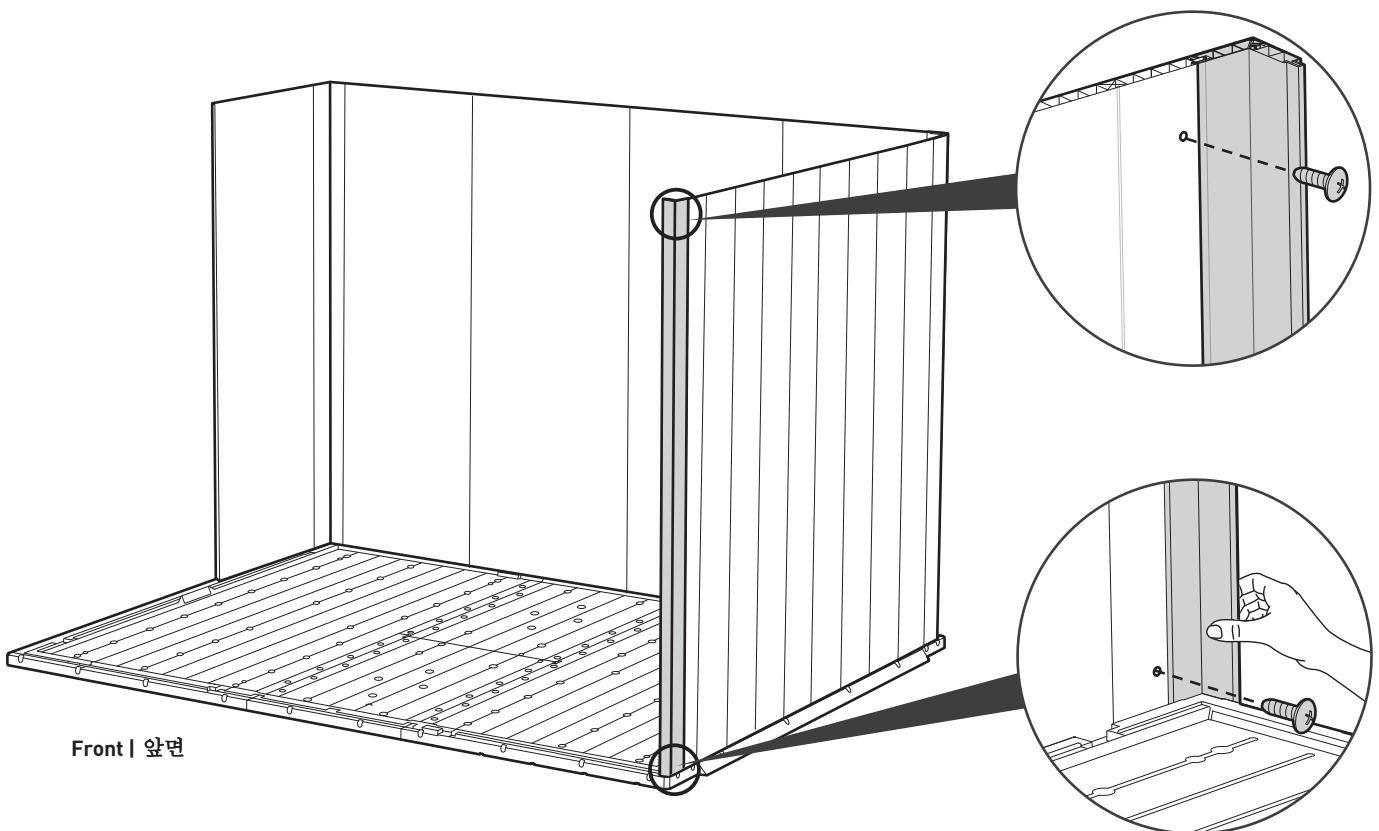



15



oLP7 (x2)



KP (x2)

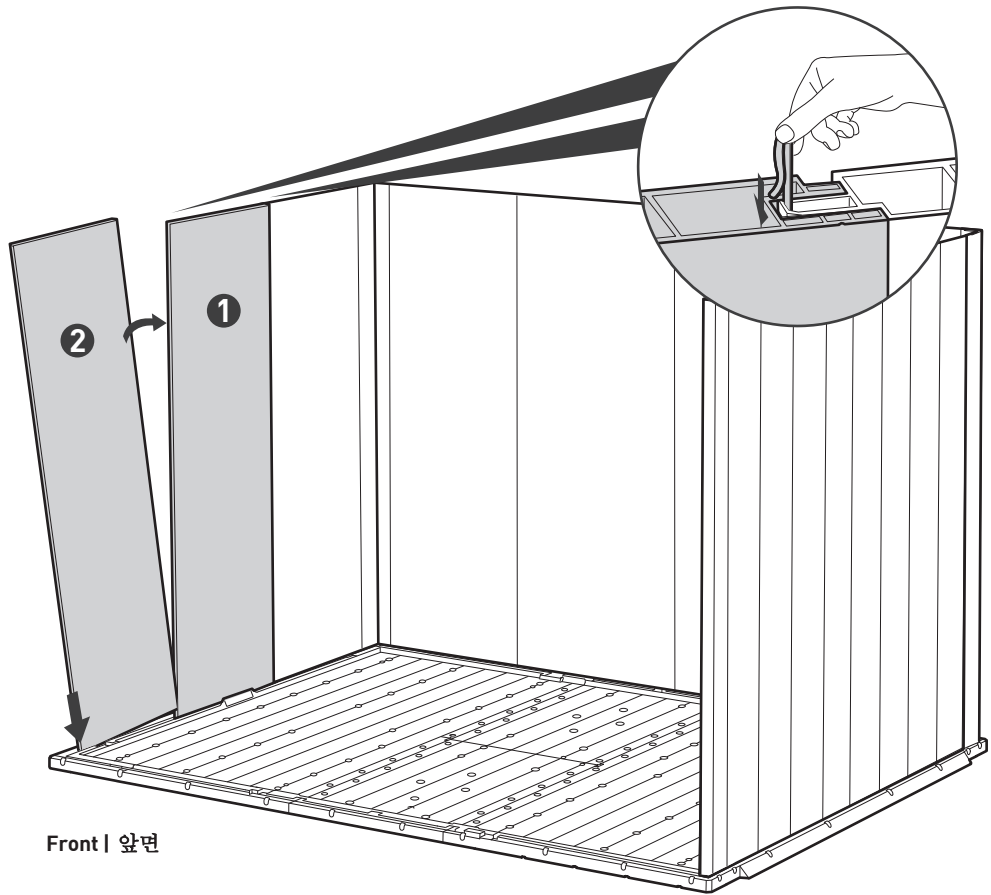
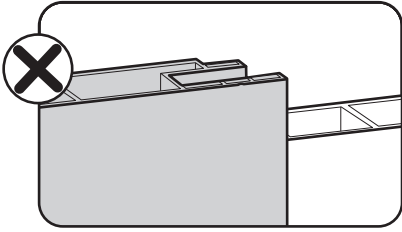
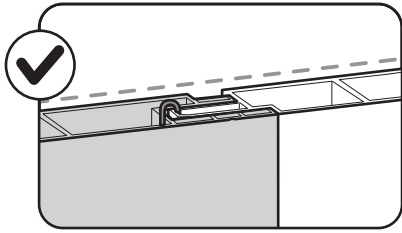

Front | 앞면

16



oLPC (x1)



KP (x1)

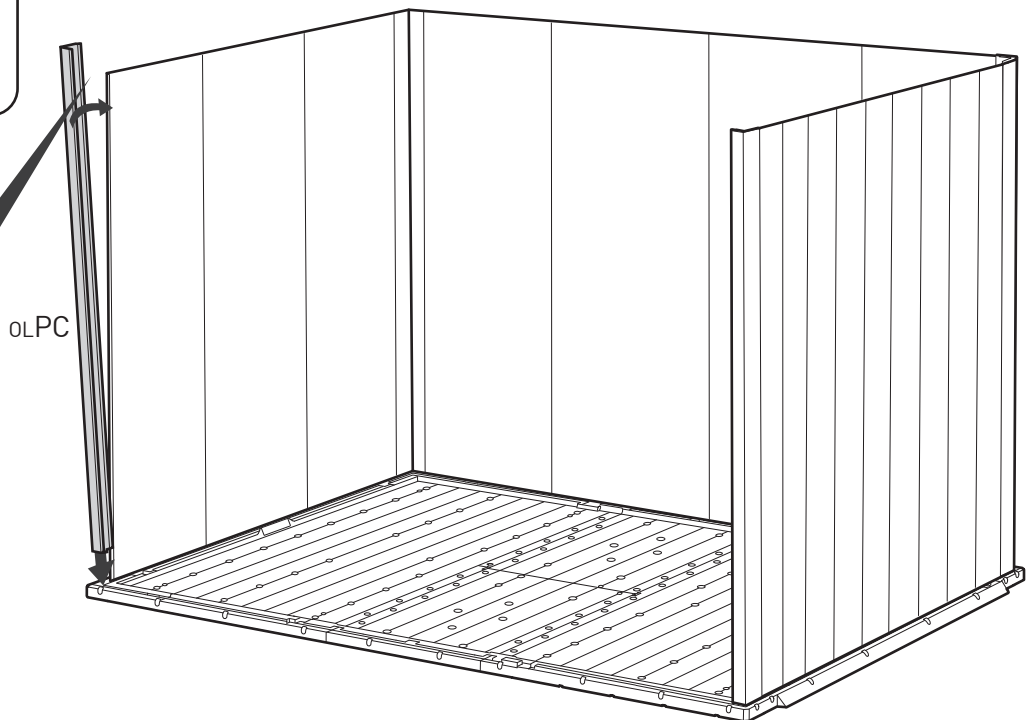
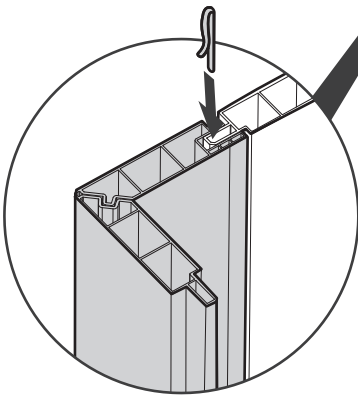
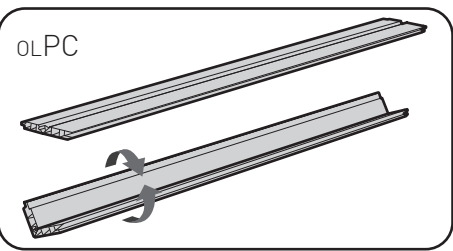



17

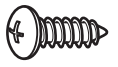

s13b (x2)

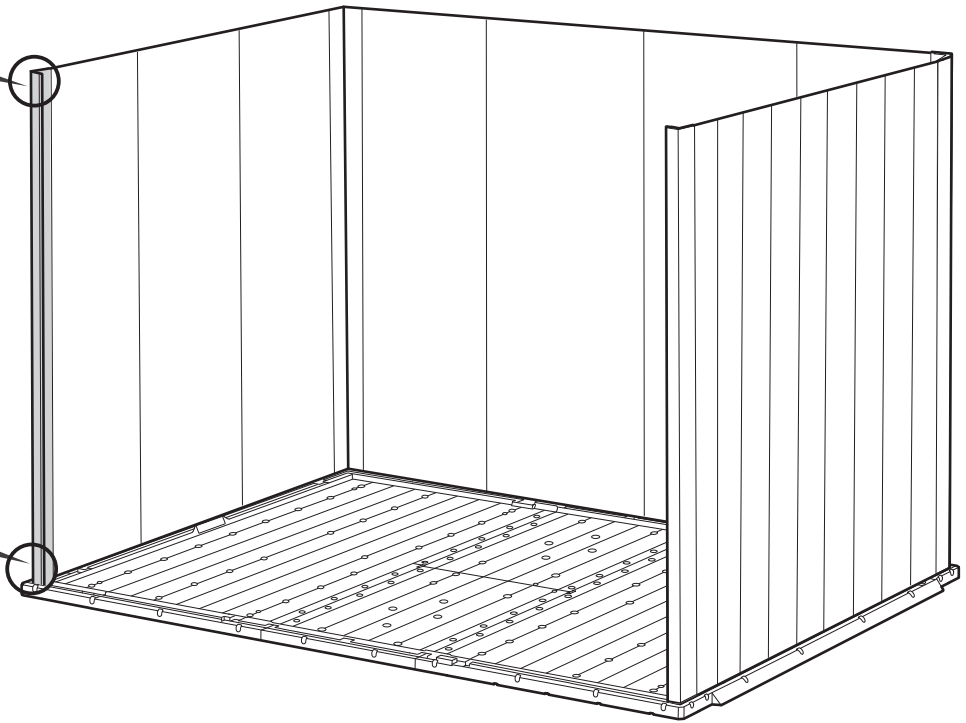
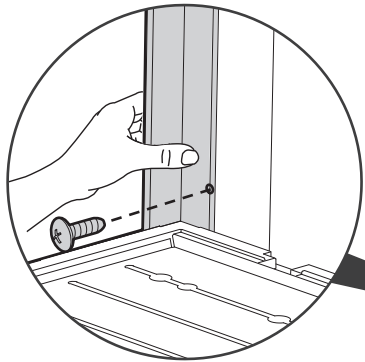
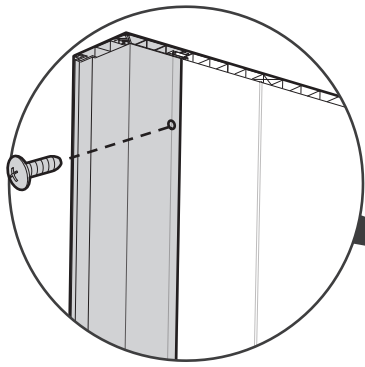



18



oLP7 (x1)



KP (x1)

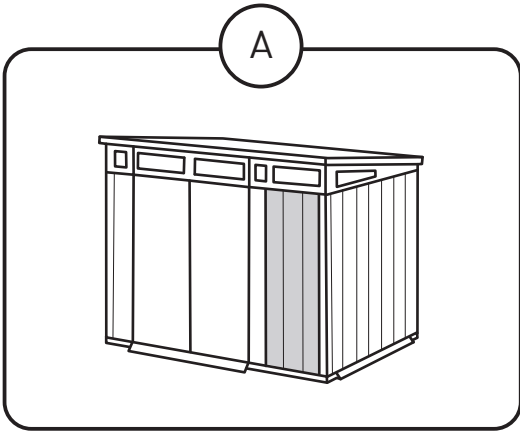

OR

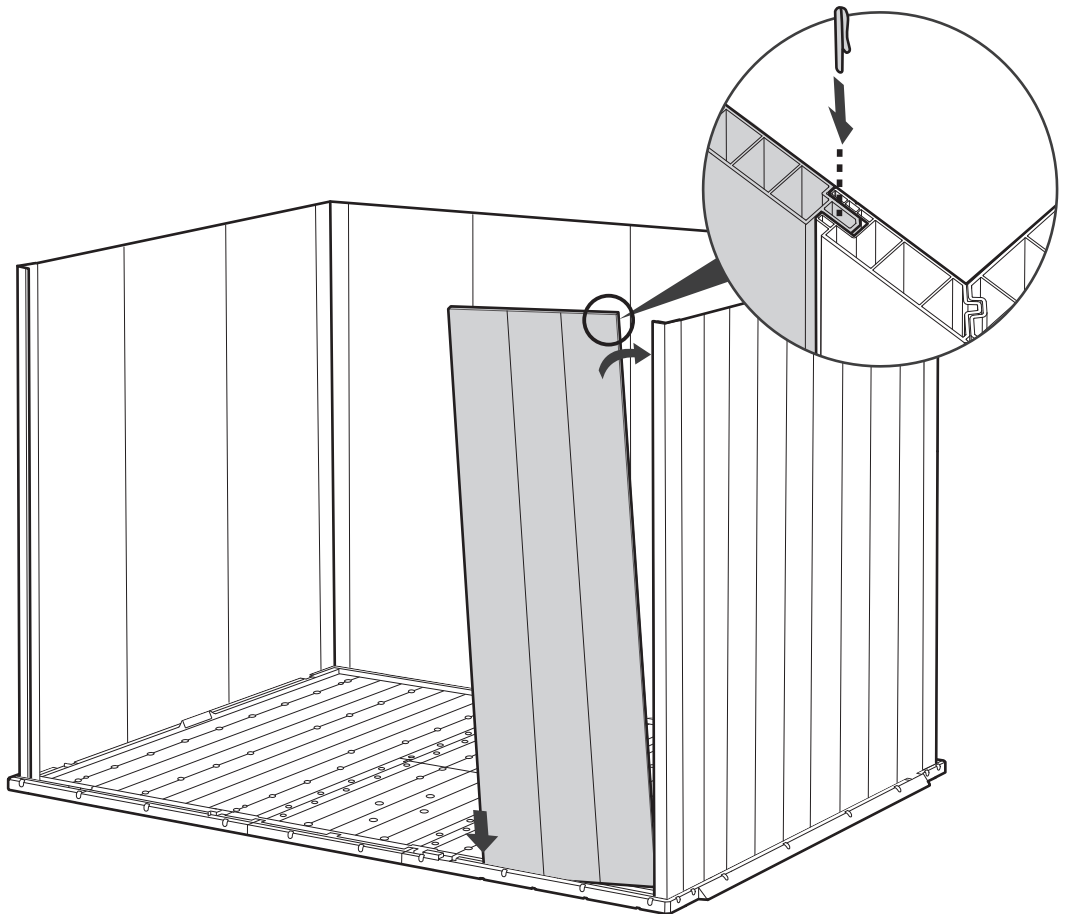
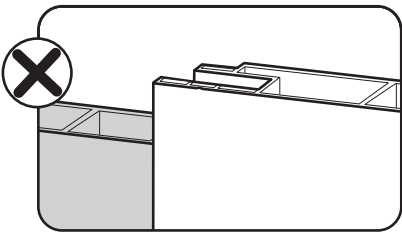
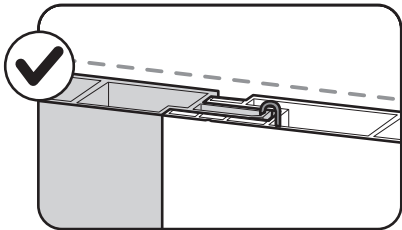
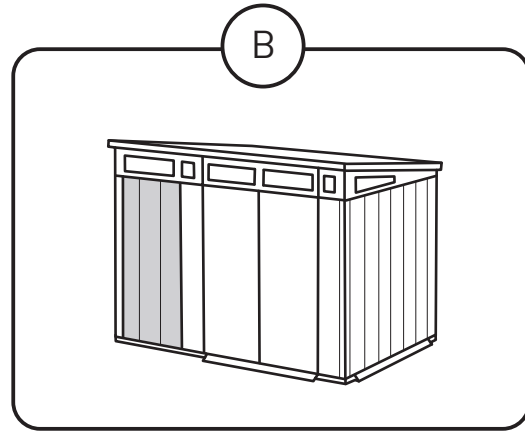



19

 s13b (x2)

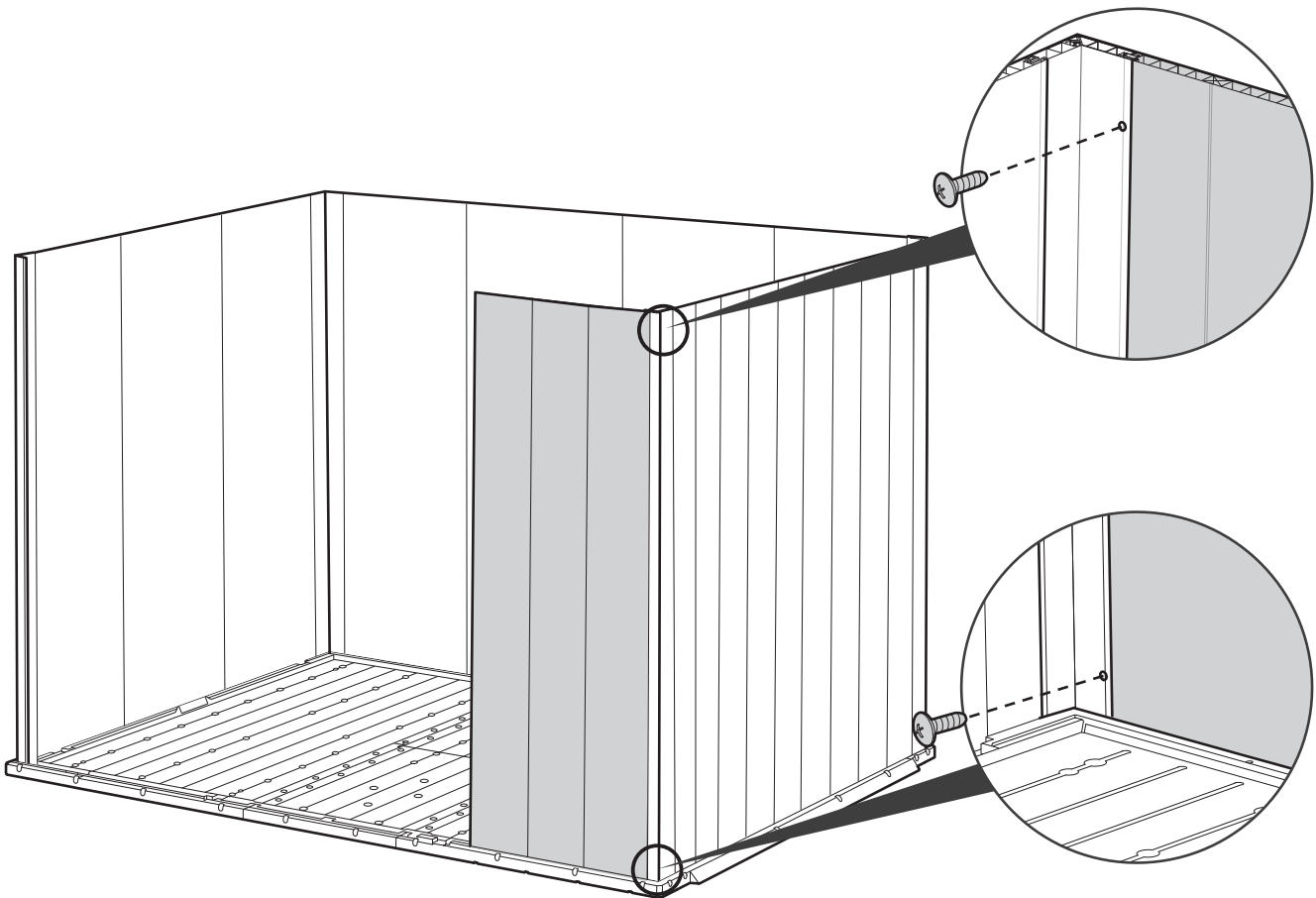

20

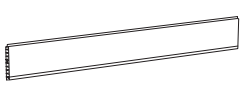
 NEPF (x2)

 KP (x2)

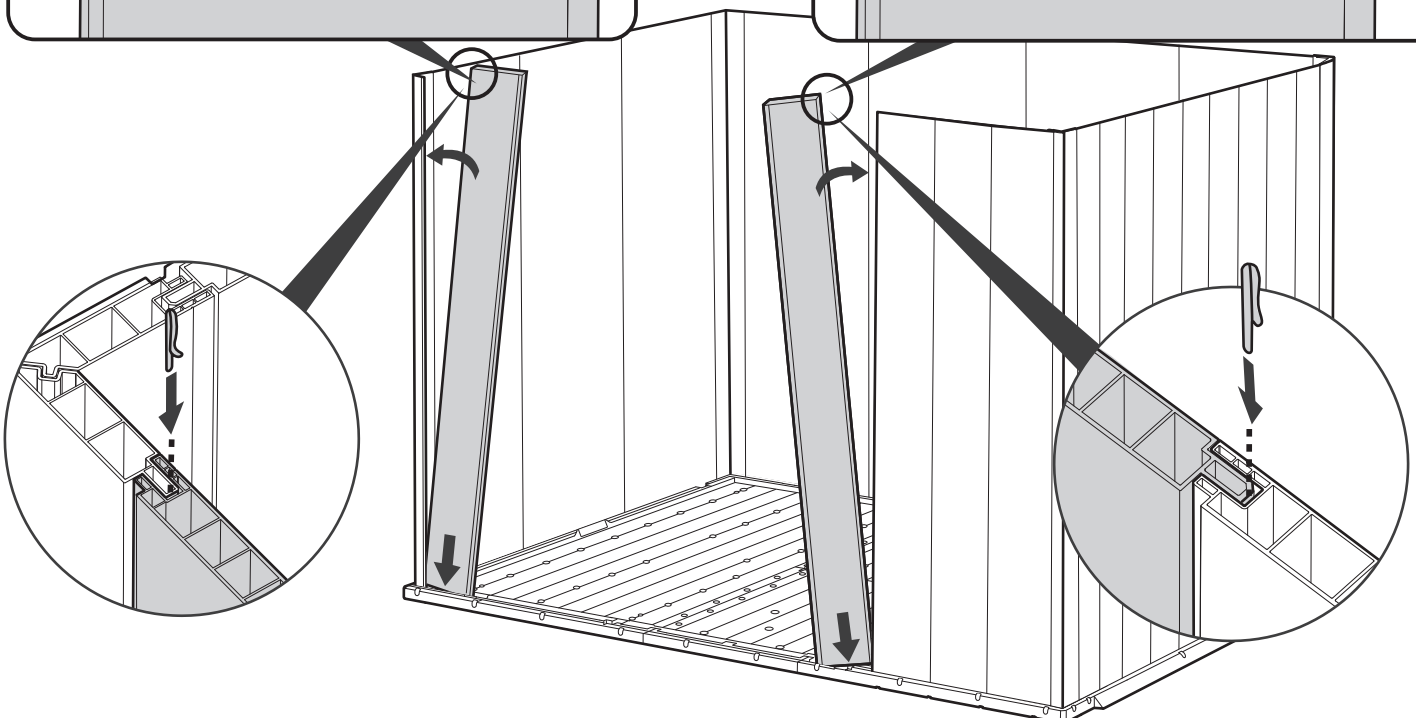
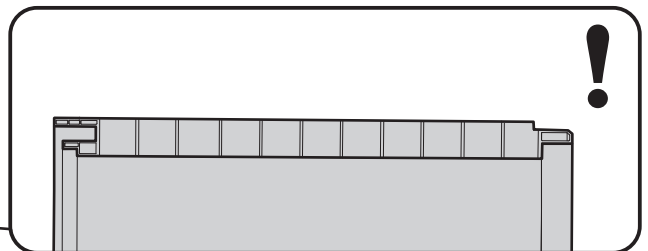
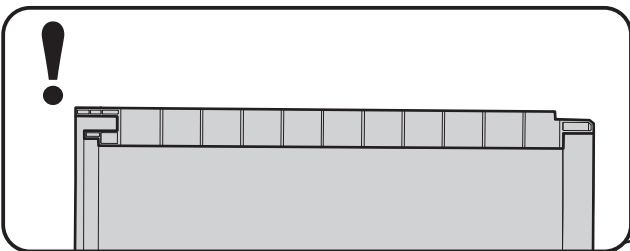



21

 s13b (x4)

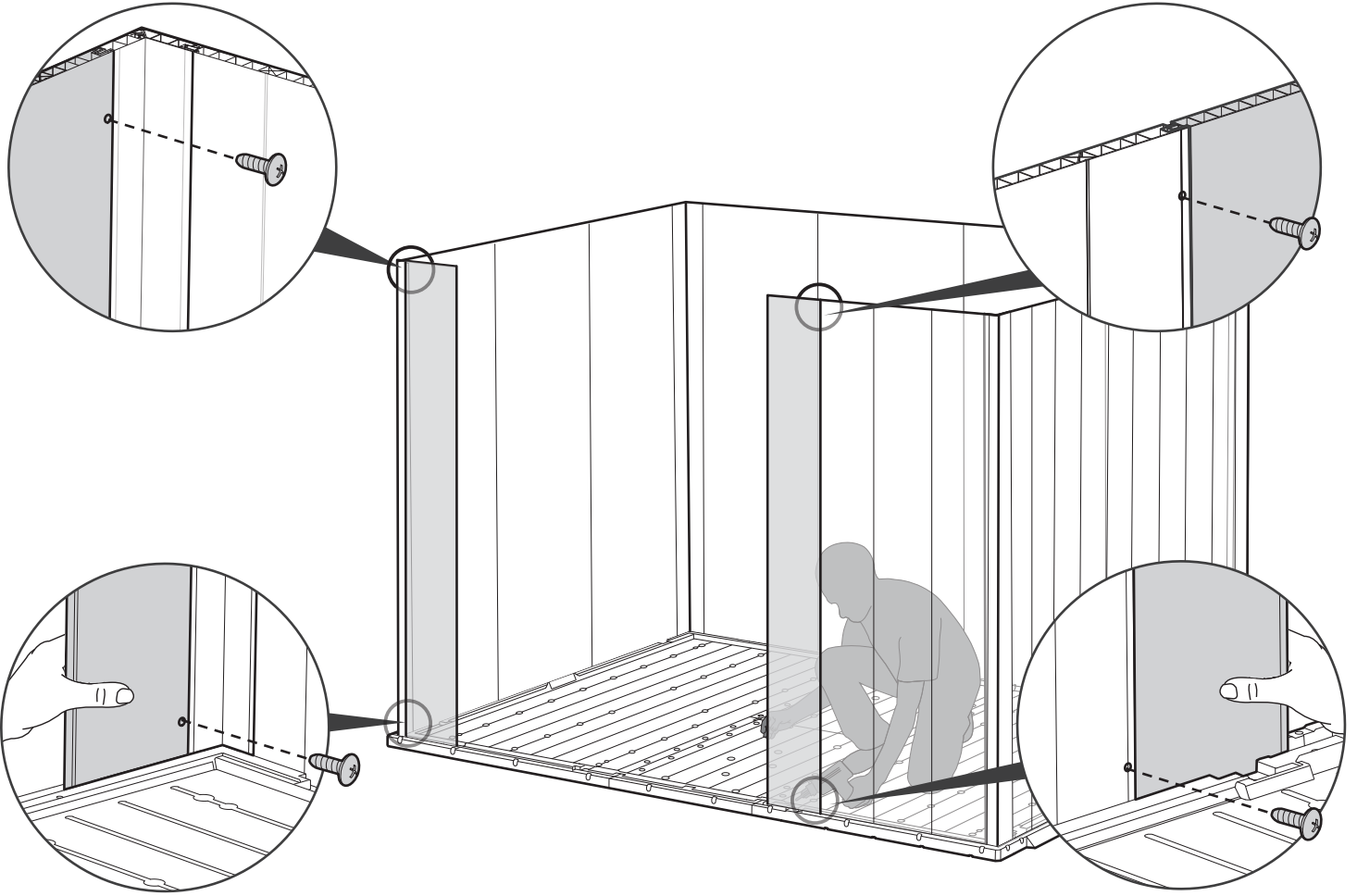



22



nEDSM (x1)

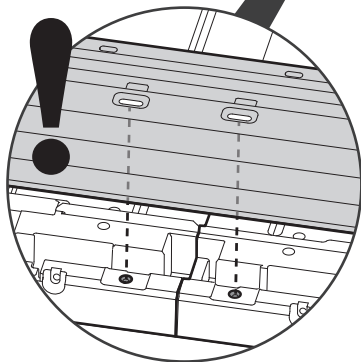
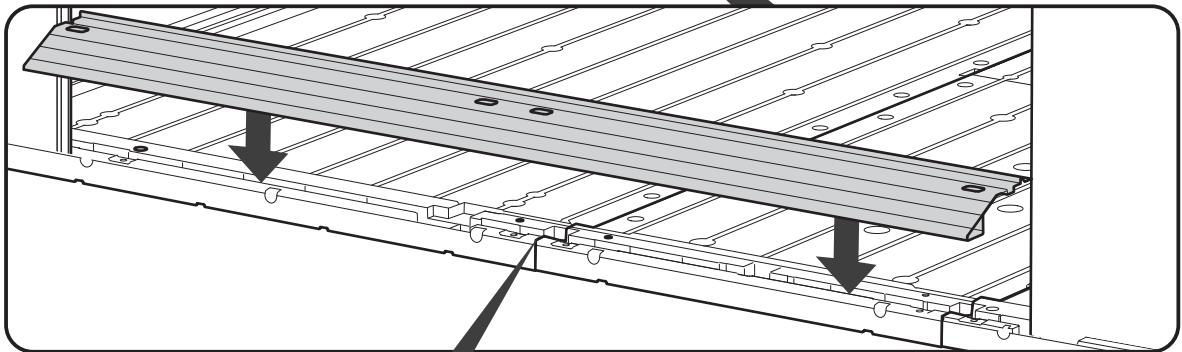
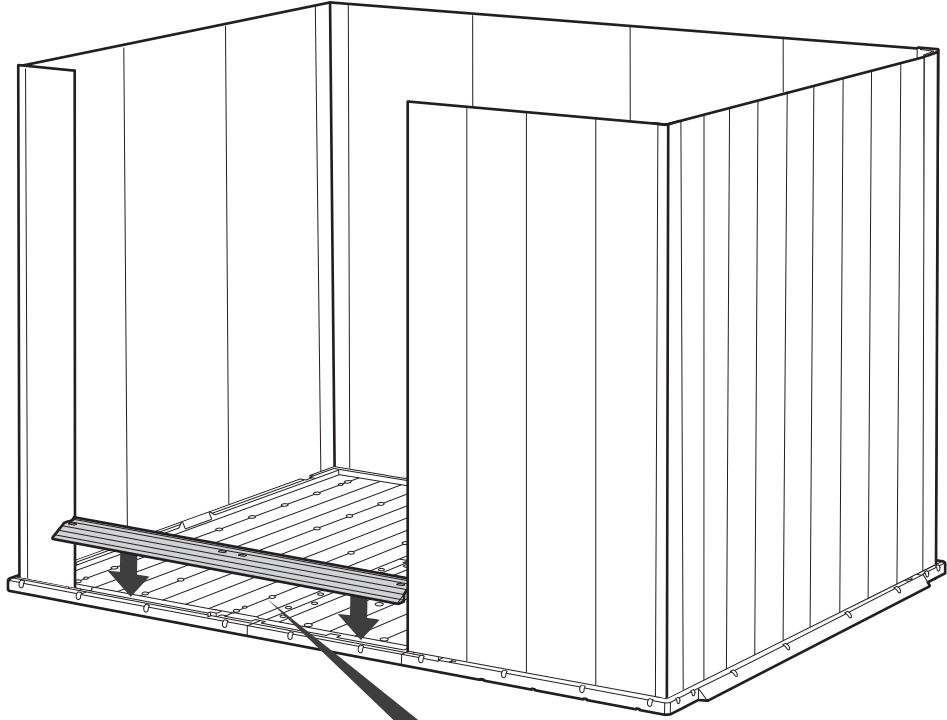



23

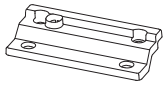

NEDS (x1)

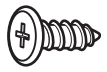

sc15 (x2)

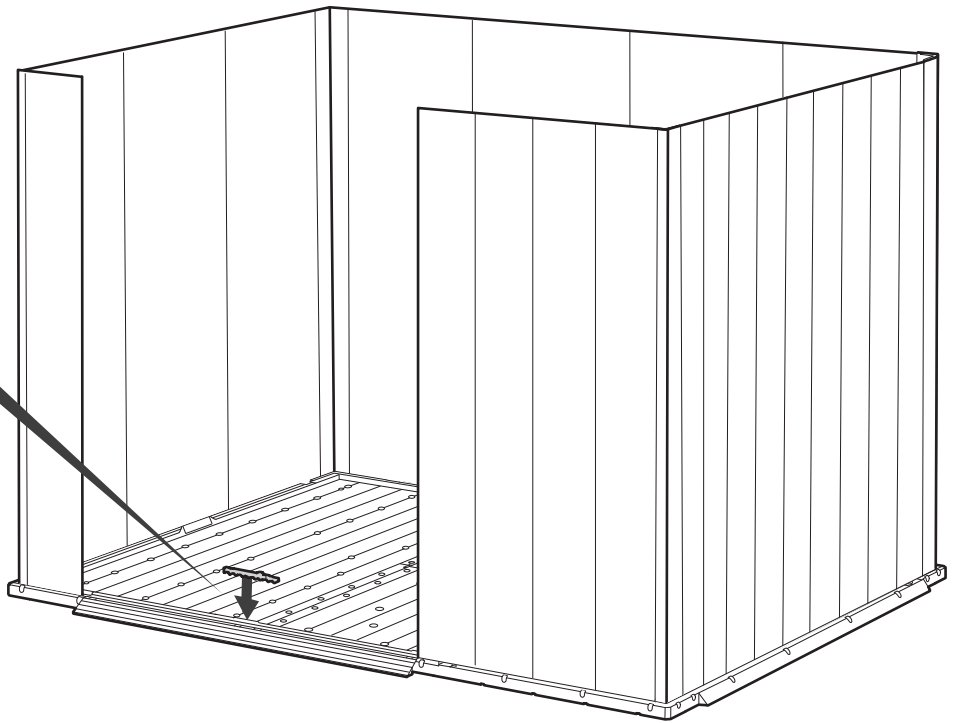
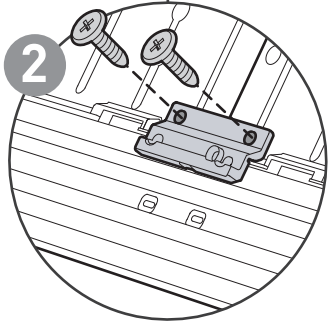
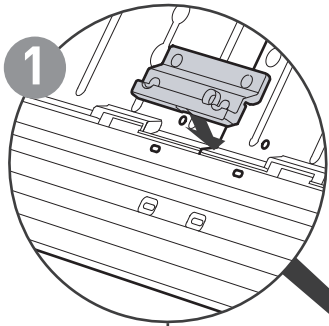



WINDOW ASSEMBLY | 창문 조립

24

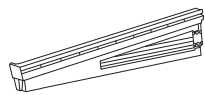

NEBLT (x1)



NELT (x1)



sc15 (x3)

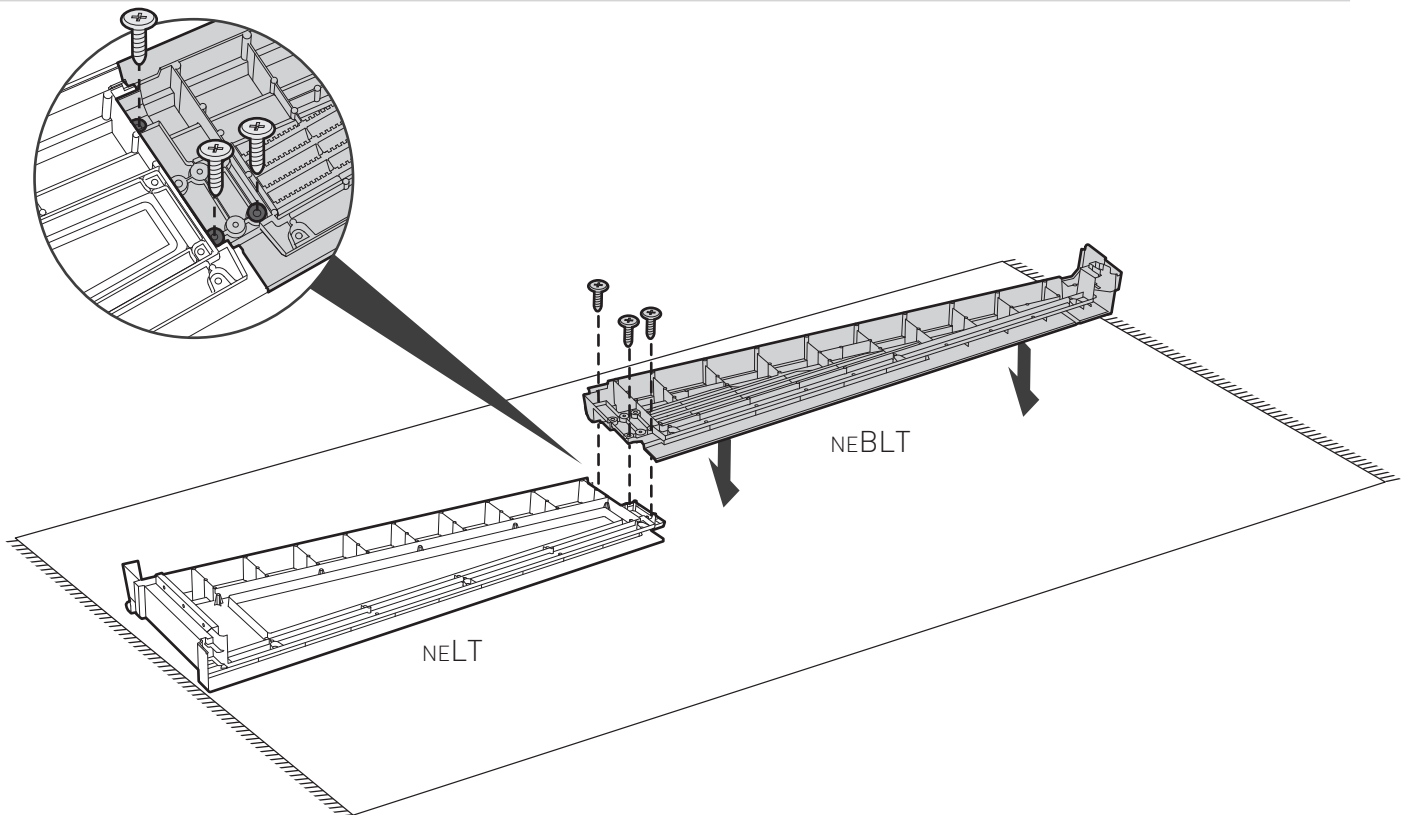

25

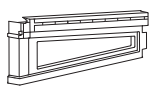

NERT (x1)

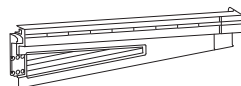

NEBRT (x1)



sc15 (x3)

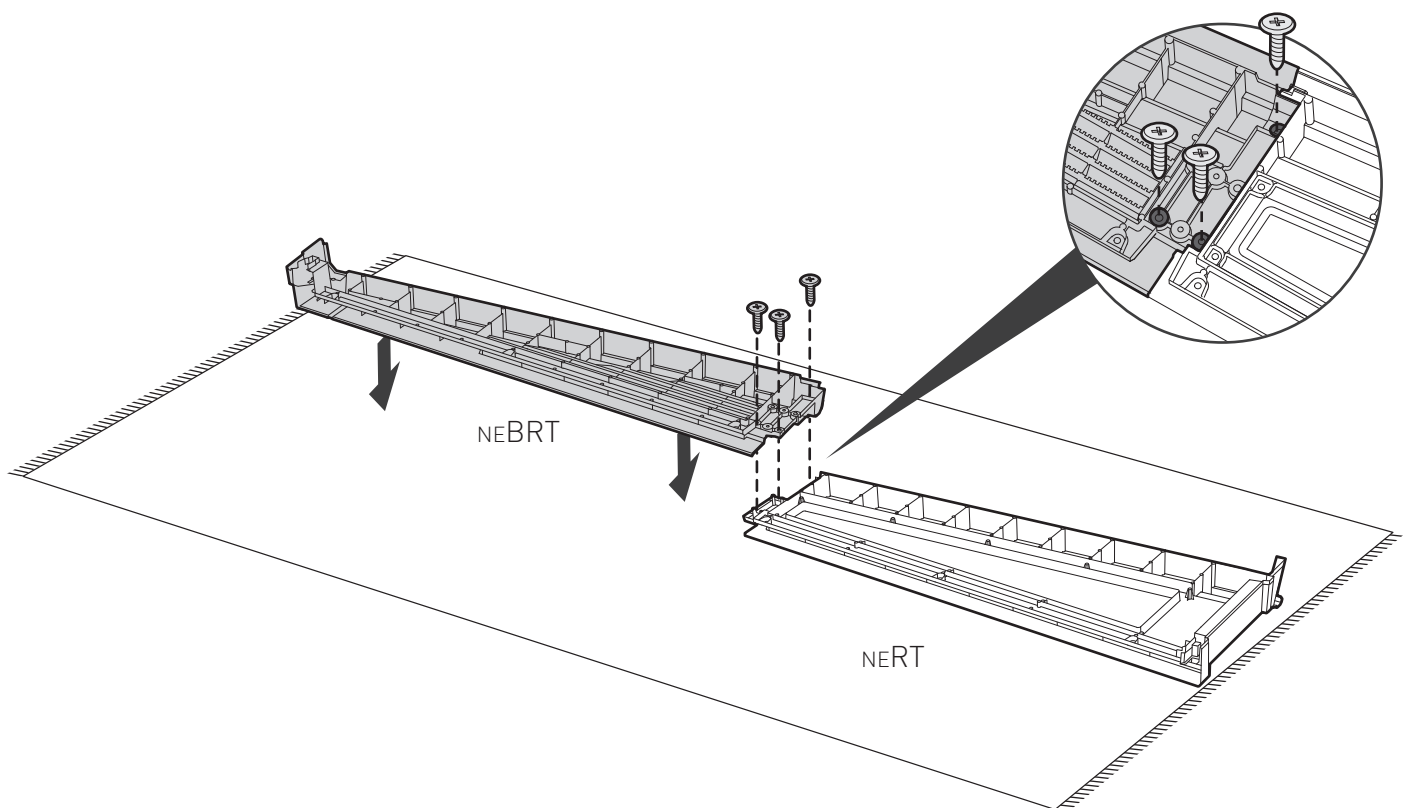



26

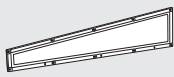

NEG T (x2)

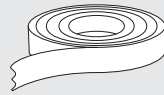

NEPL

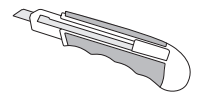

Right
오른쪽

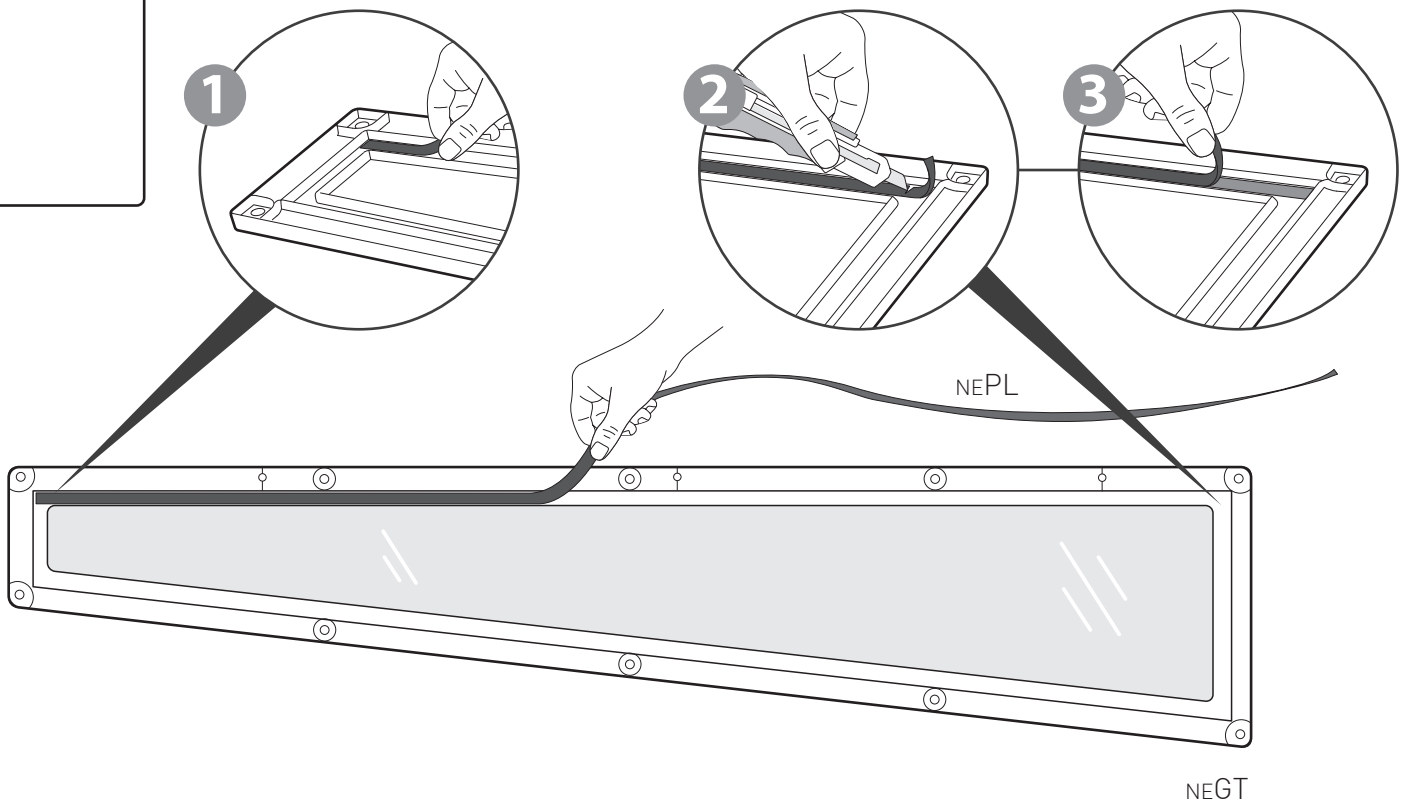

27

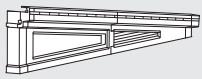

NEBRT + NERT

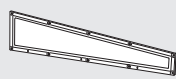

NEPL + NEG T



sc15 (x10)

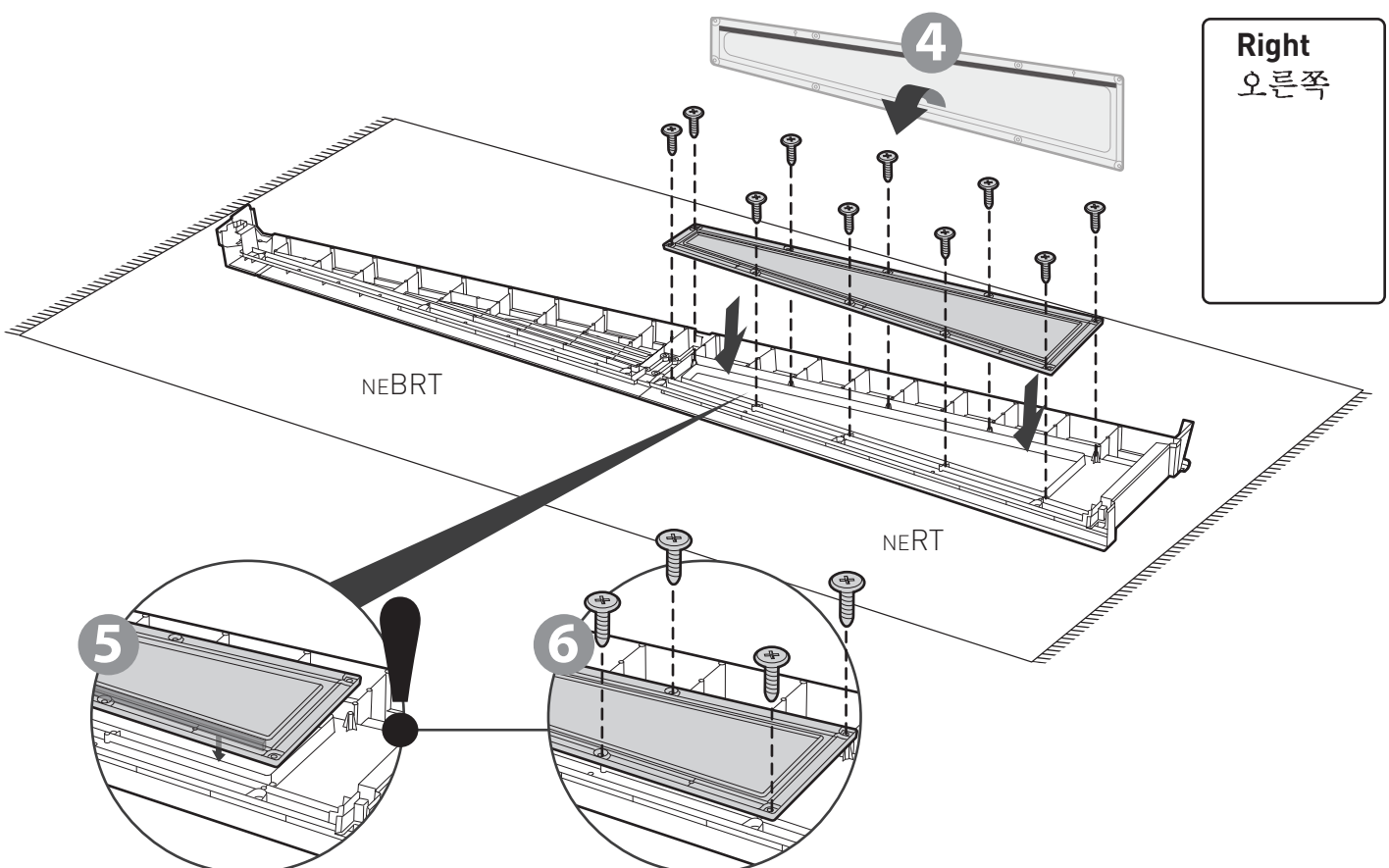

28

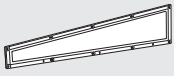

NEG T (x2)

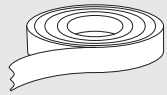

NEPL

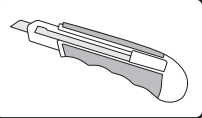

Left
왼쪽

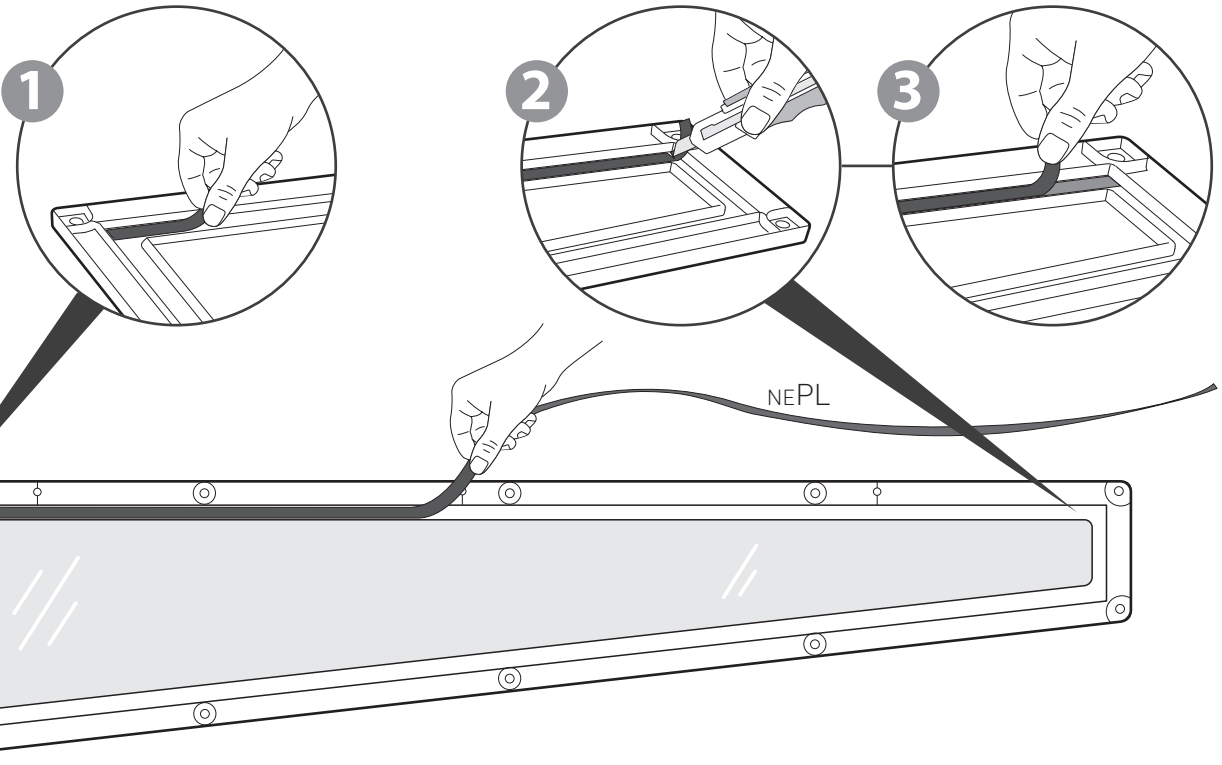

NEG T

29

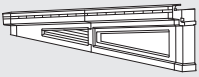

NEL T + NEBL T

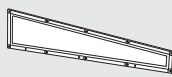

NEPL + NEG T



sc15 (x10)

Left
왼쪽

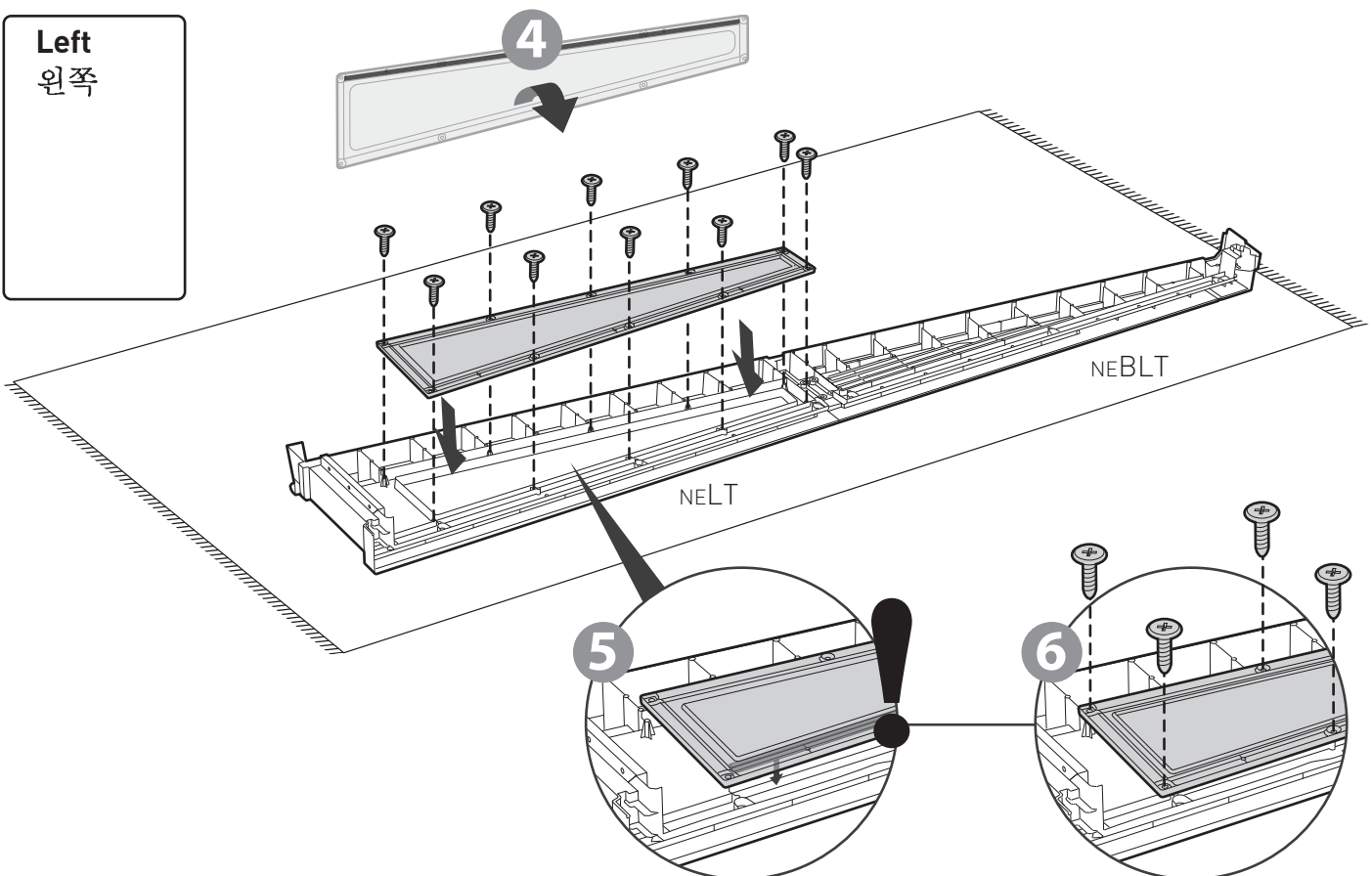



30



NEFFM (x1)

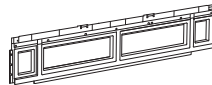

NEFF (x1)



sc15 (x2)

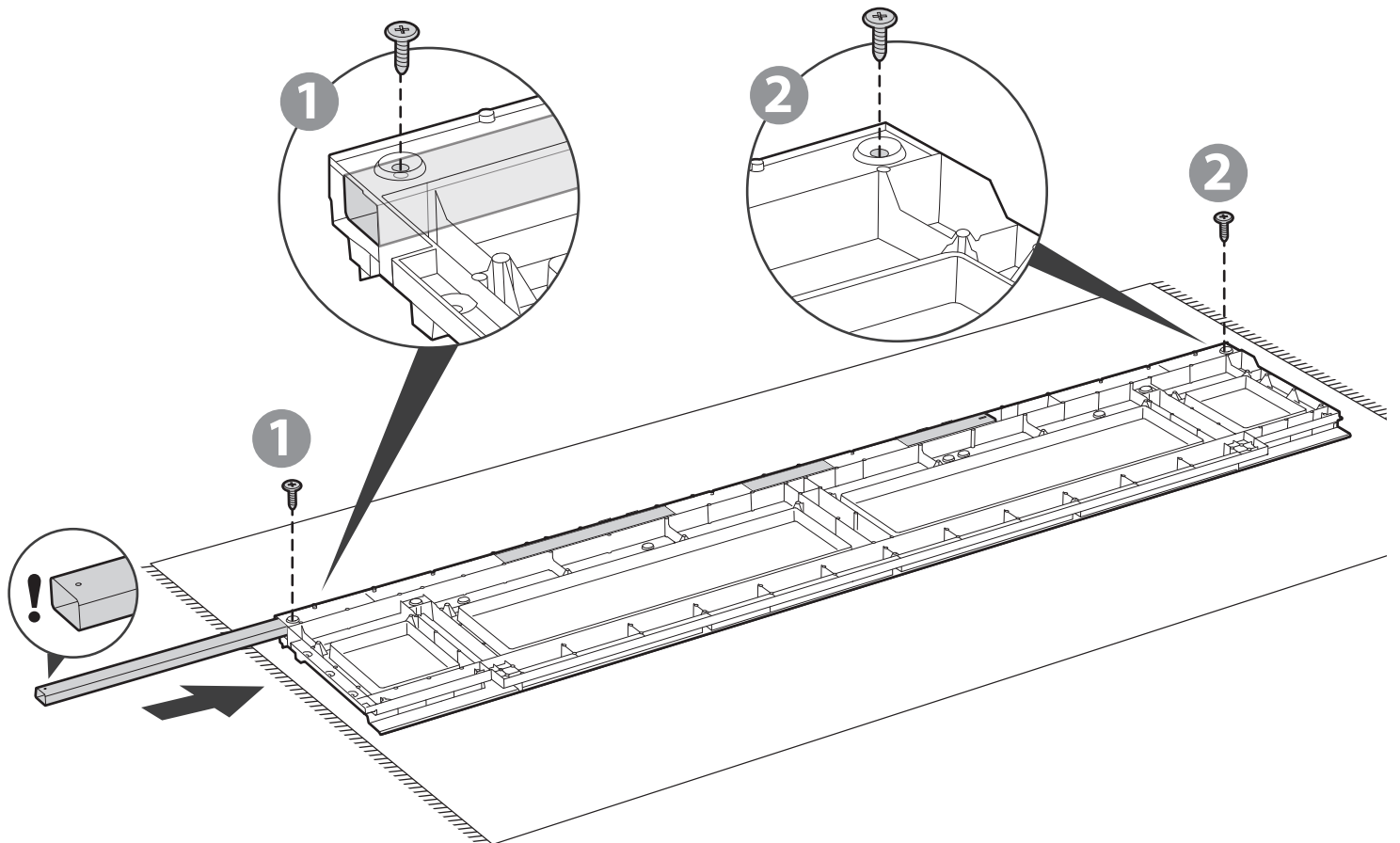

31



NETDP (x1)



sc15 (x3)

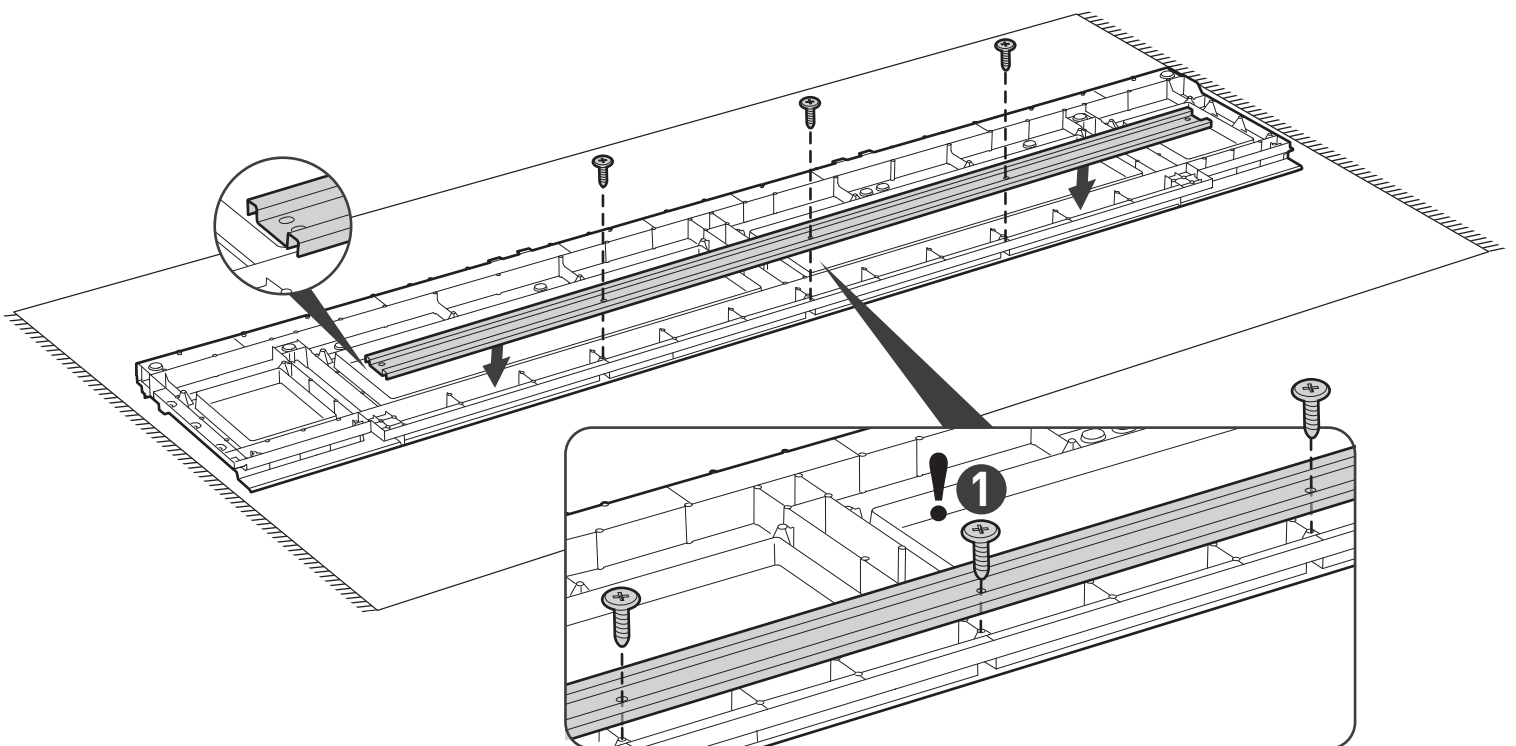



32

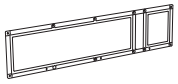

NEGR (x2)



NEPL



sc15 (x24)

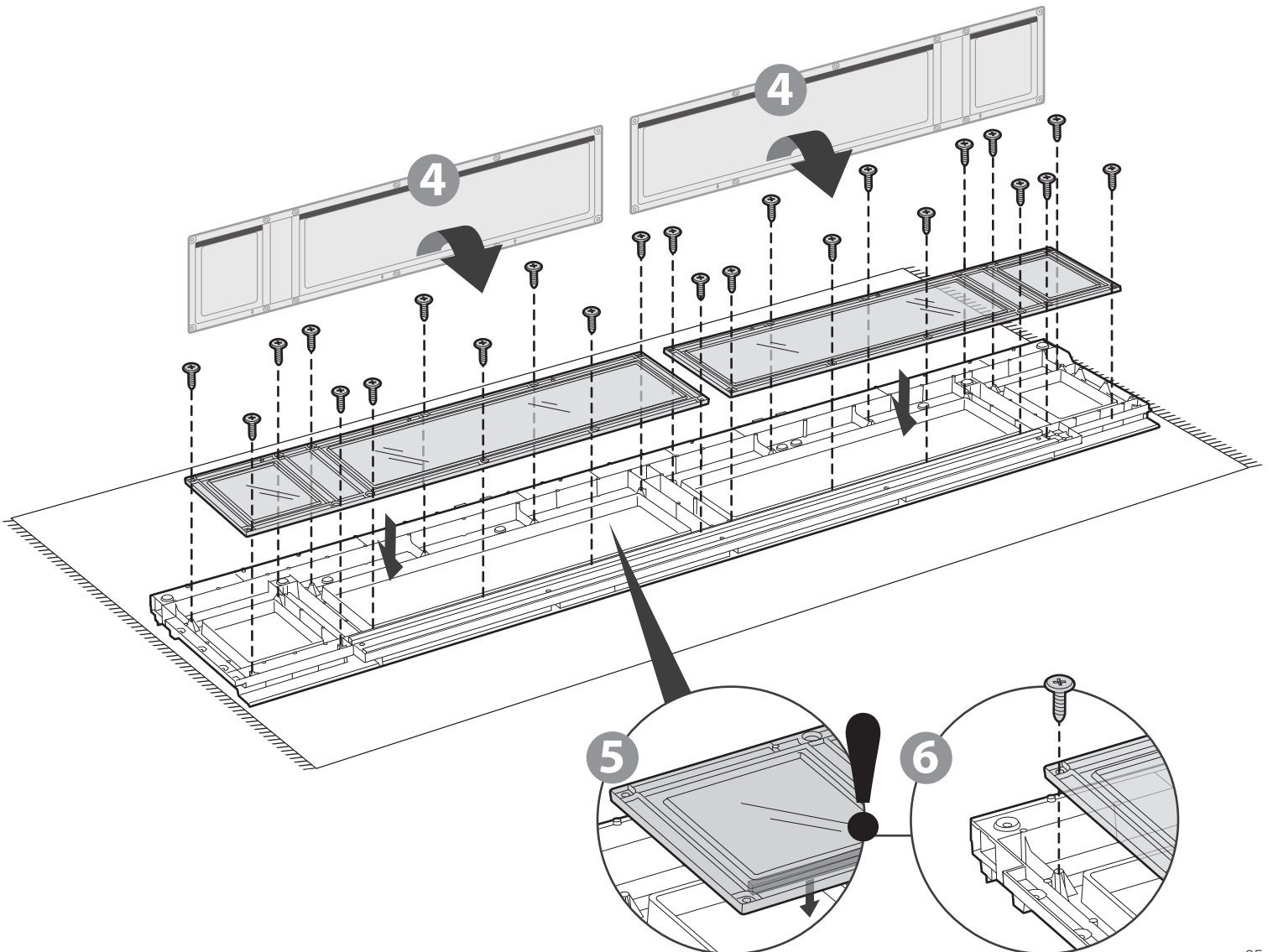
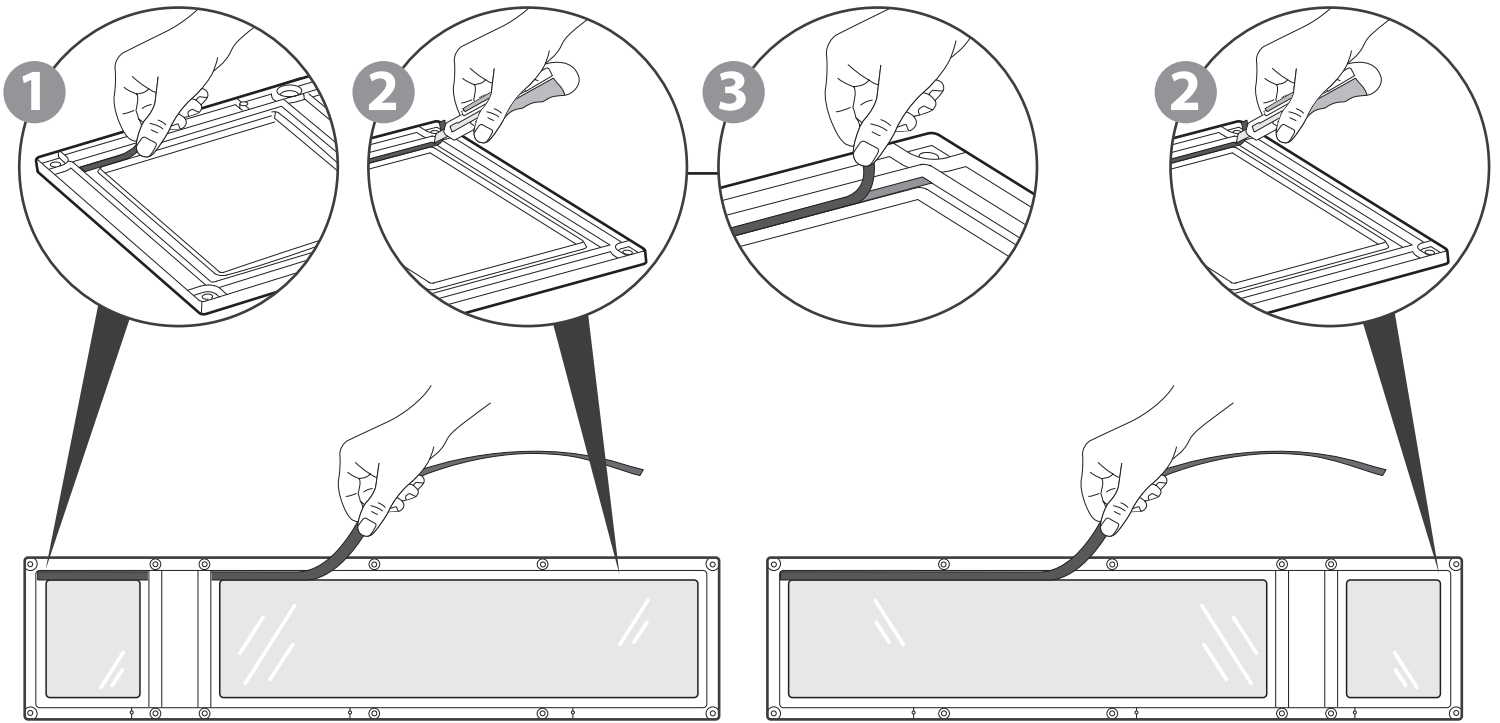
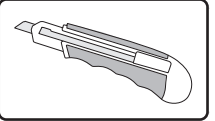



33

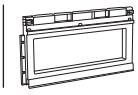

NEFE (x1)



NEGE (x1)



NEPL

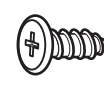

sc15 (x8)

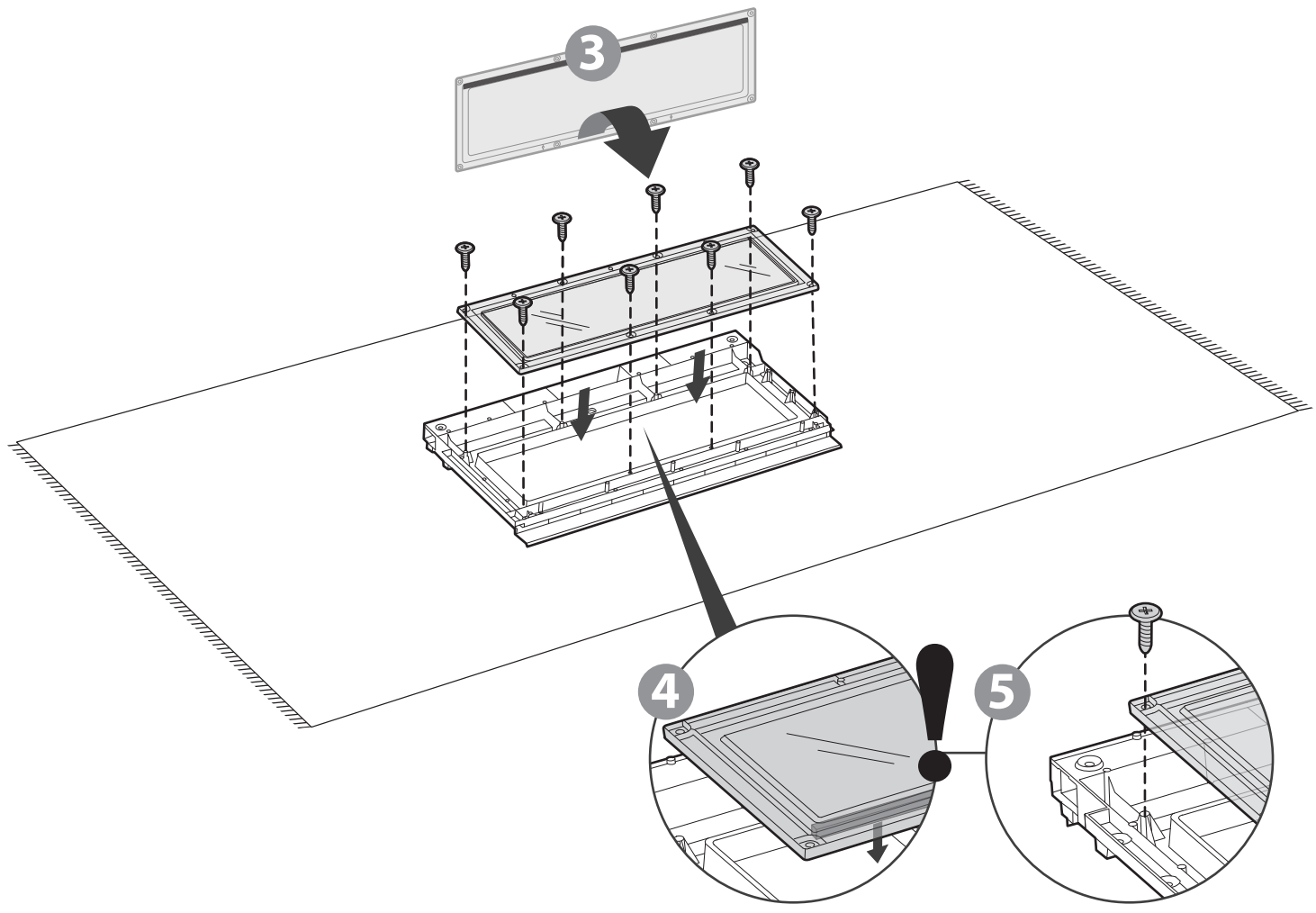
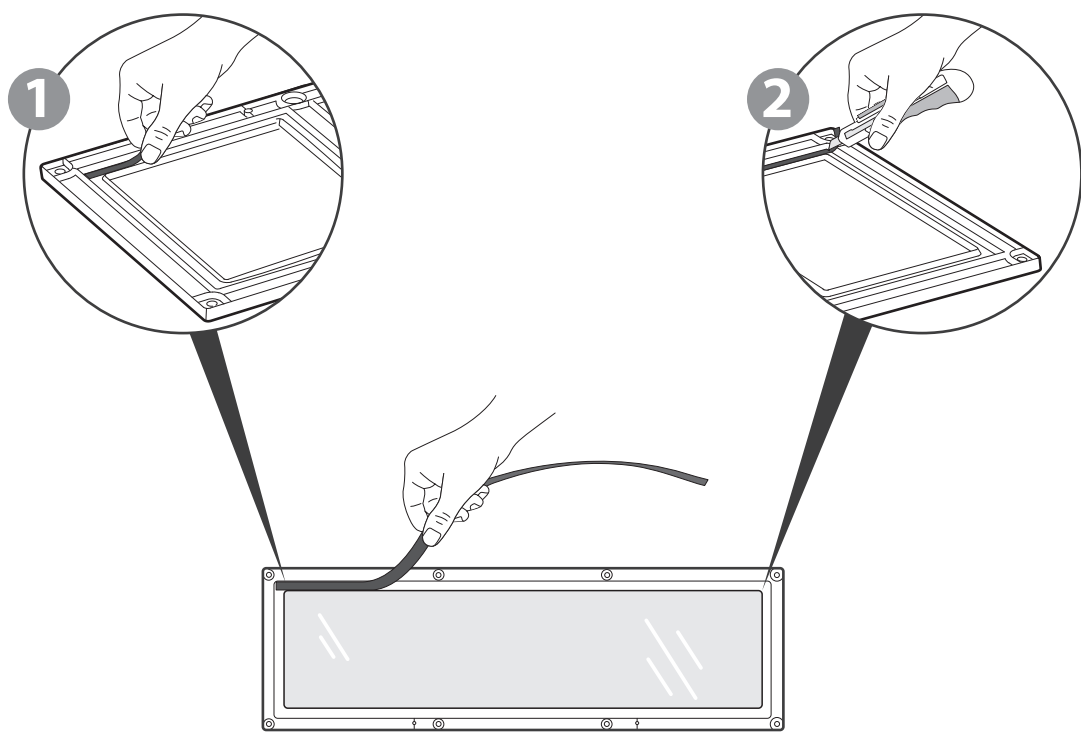
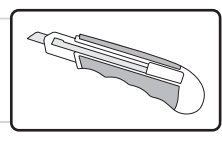



34

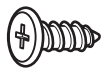
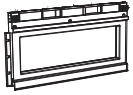

sc15 (x3)

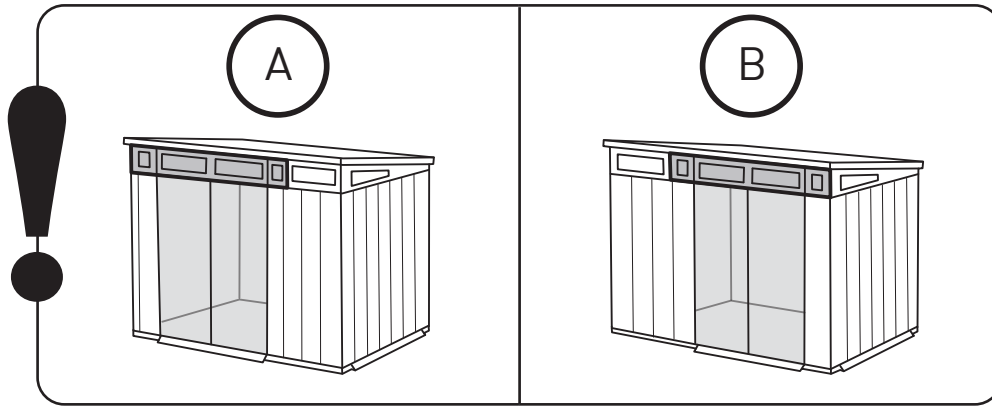

A

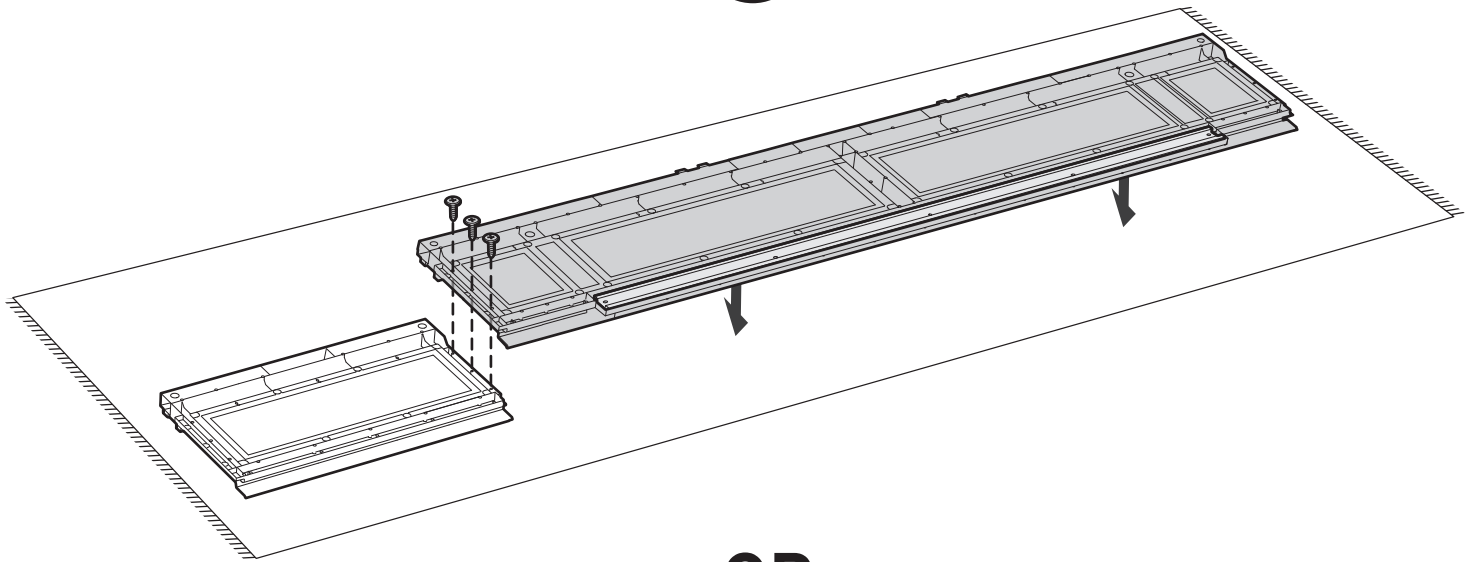

OR

B

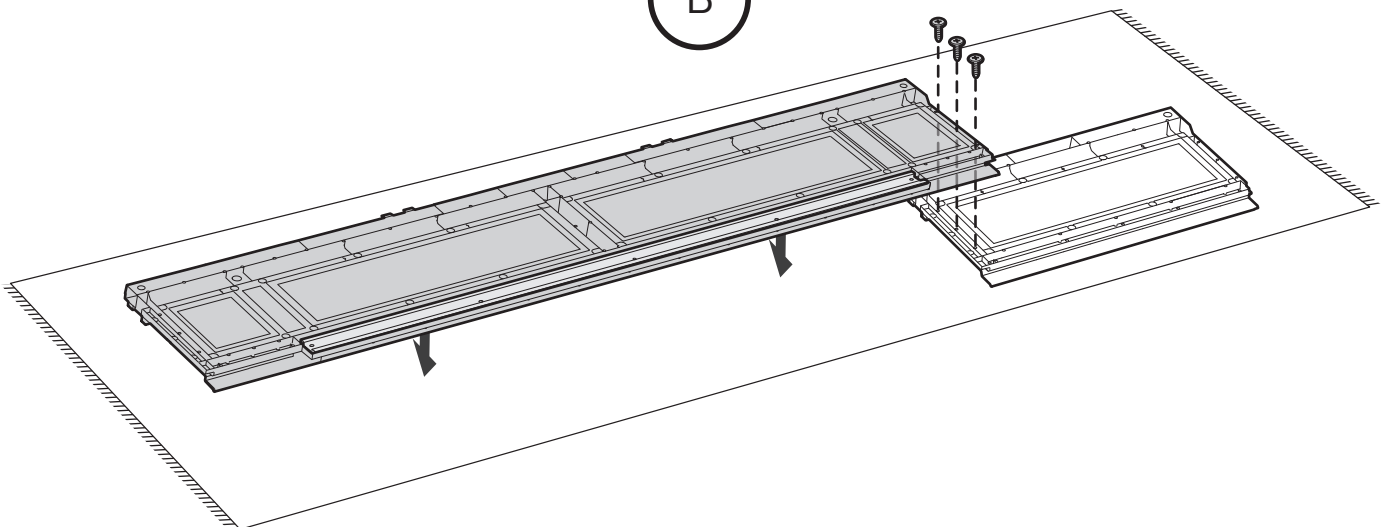



35

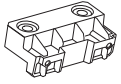

NEMRC (x1)

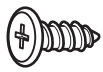

sc15 (x2)

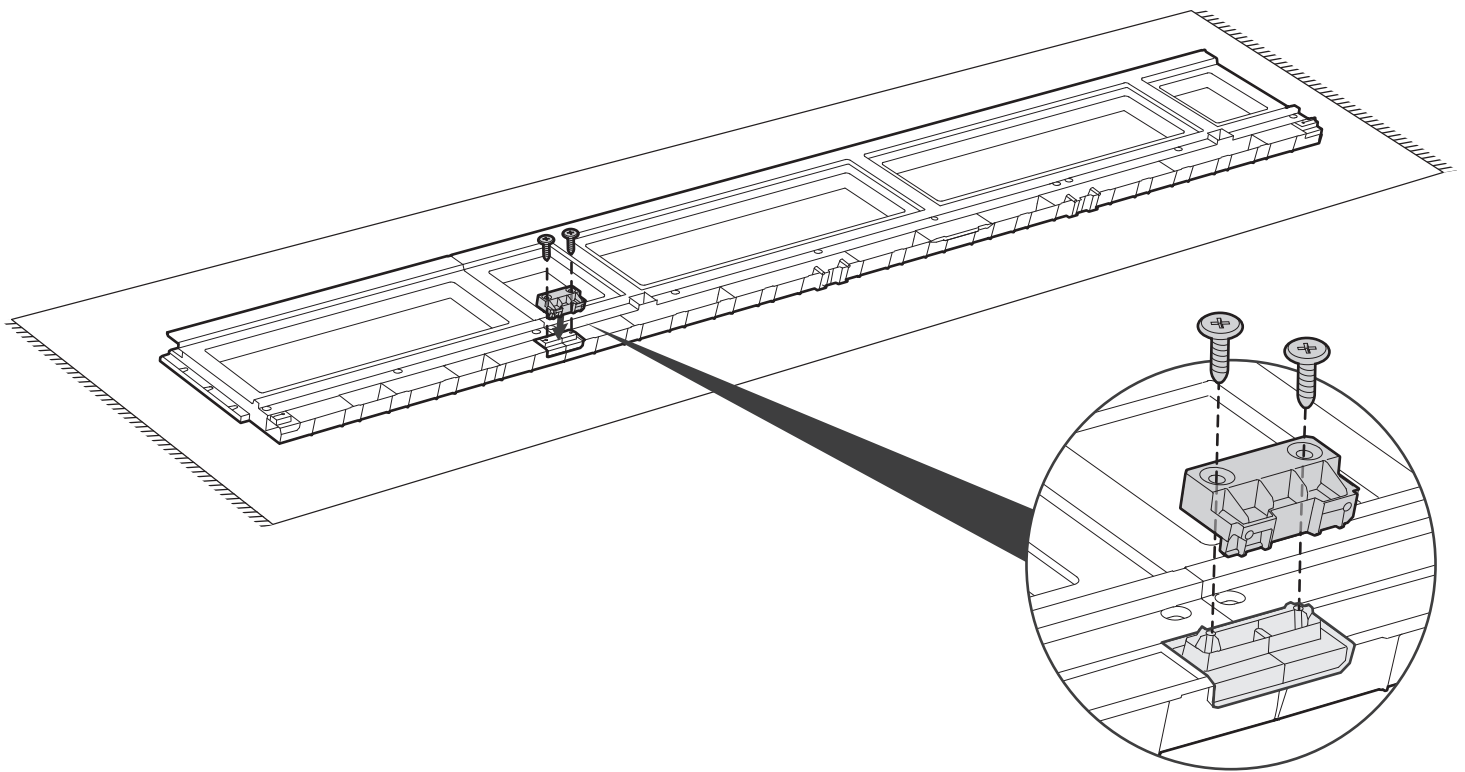
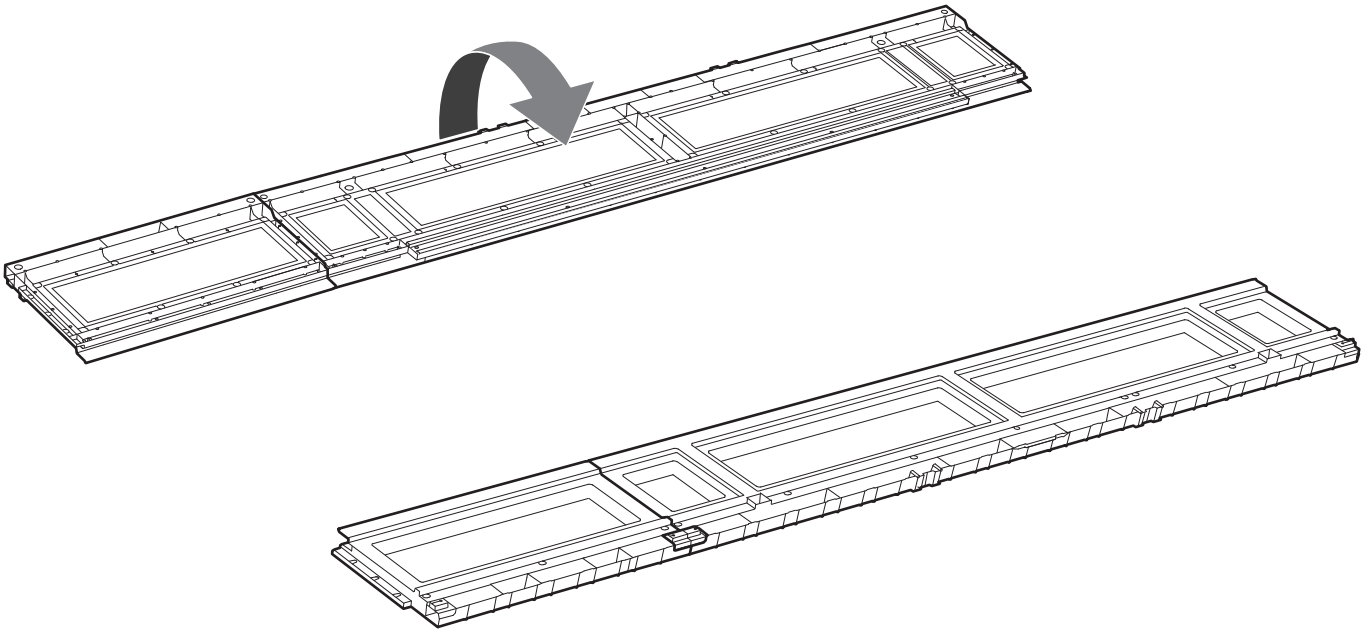



36

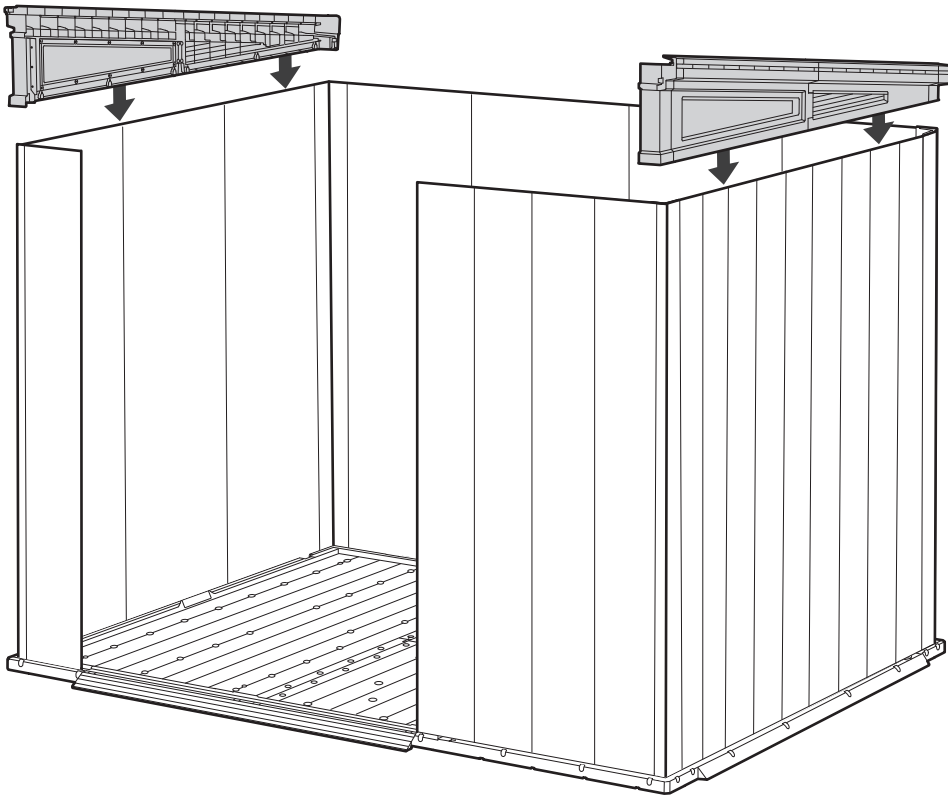

37

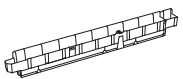

NELD (x1)

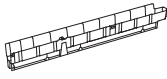

NERD (x1)

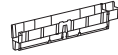

NEDE (x1)



sc15 (x6)

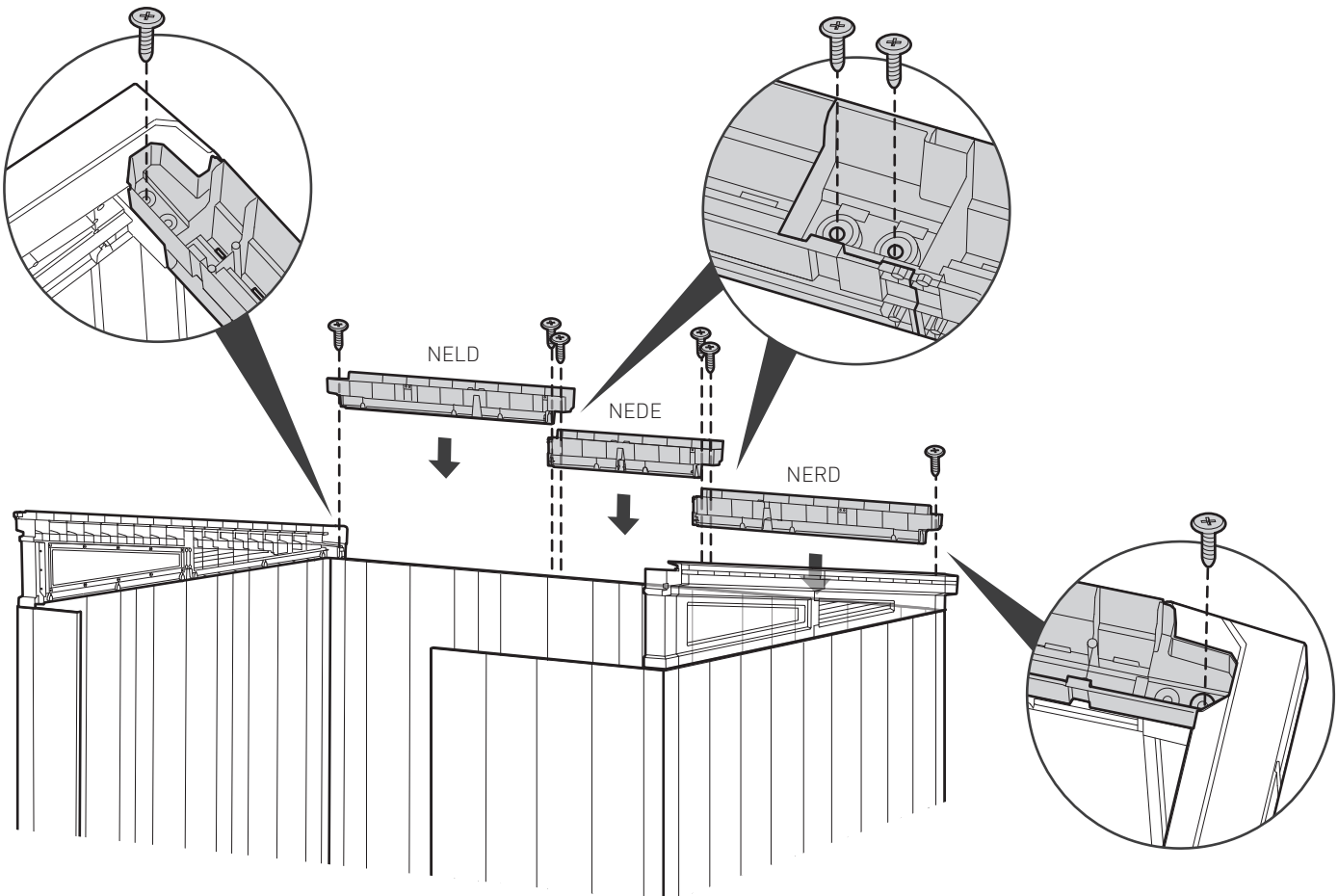



38

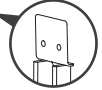

NEBPM (x1)



sc15 (x2)

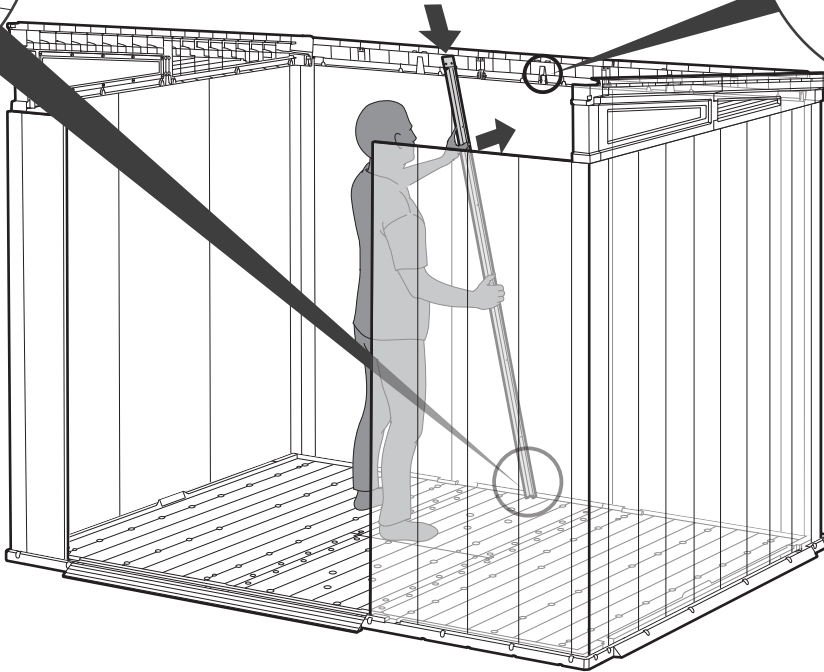
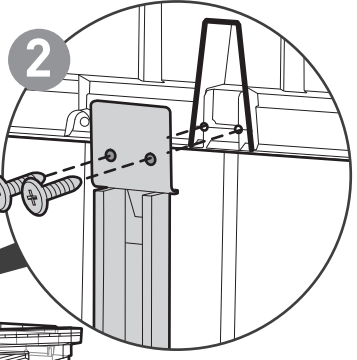
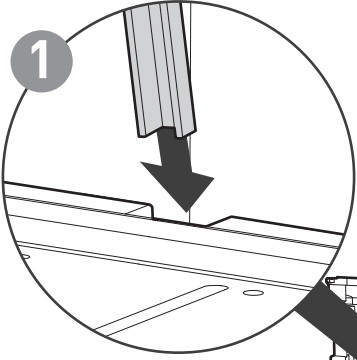

39



NESM9 (x1)



sc15 (x2)

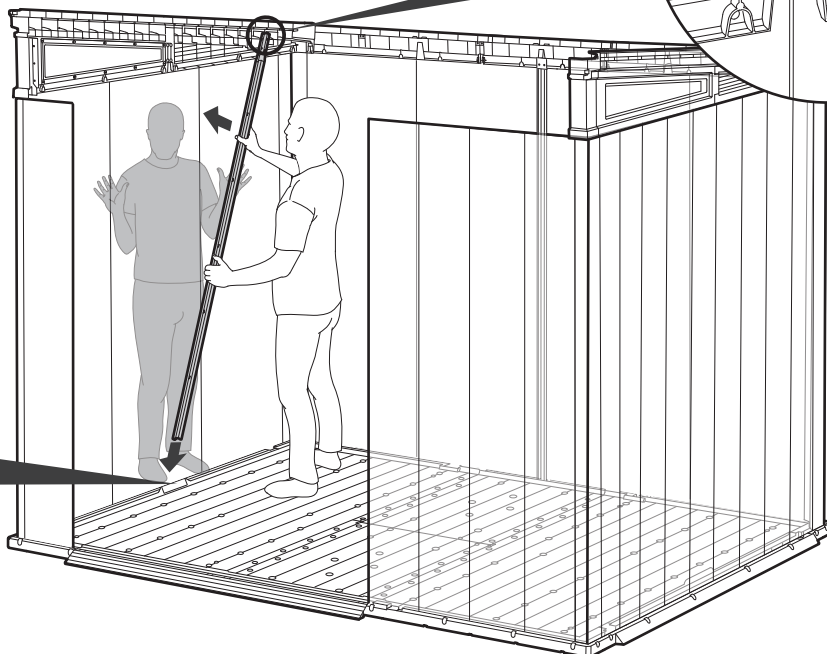
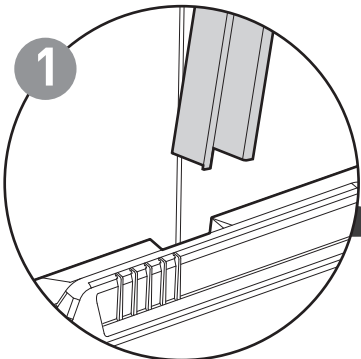
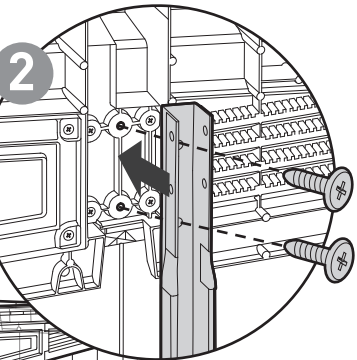



40



NESM9 (x1)

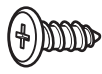

sc15 (x2)

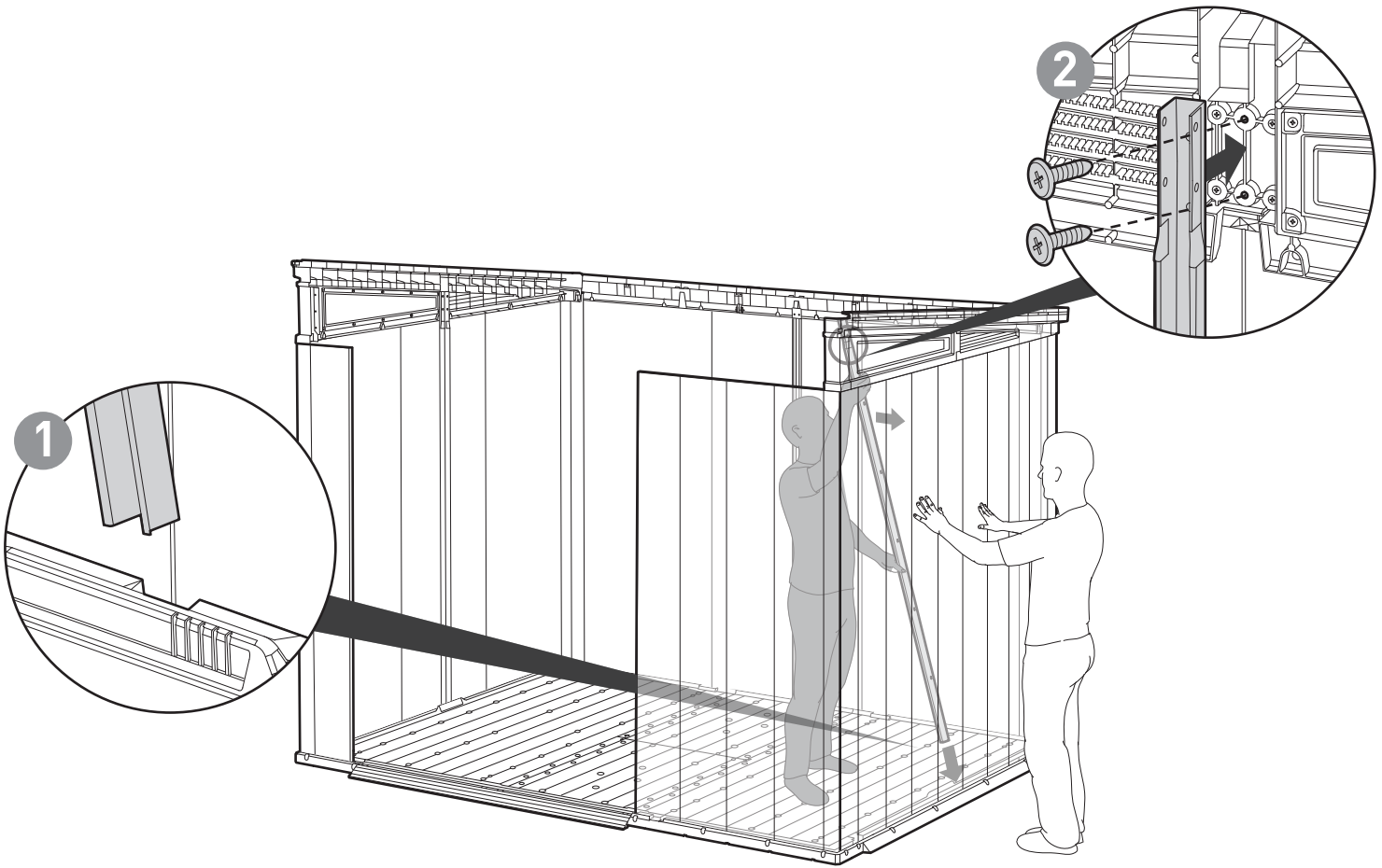

41



NESC9 (x2)

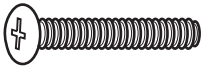

sc8 (x4)



sc15 (x4)

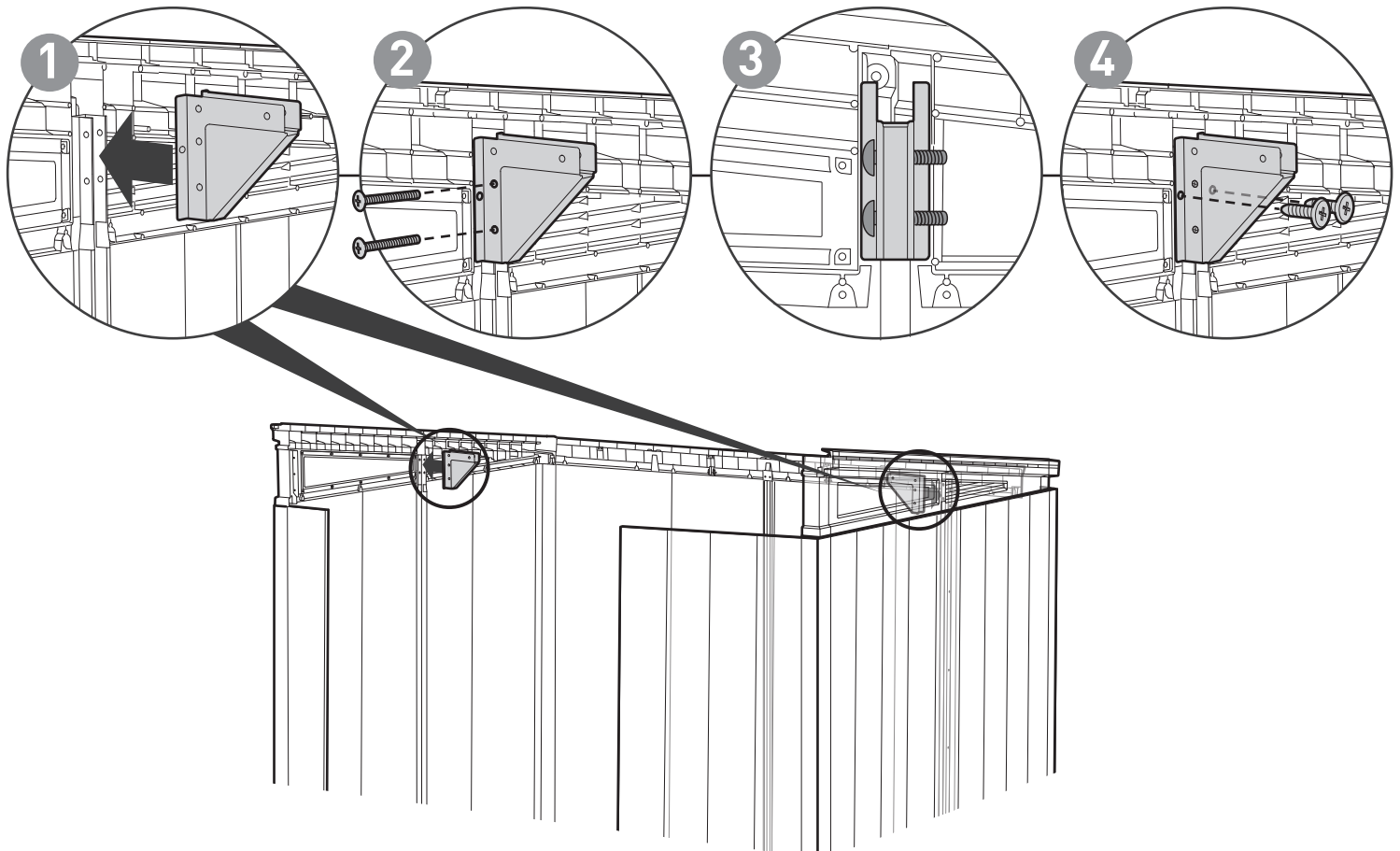



42



NERB9 (x1)

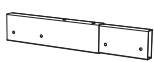

NEBC9 (x2)



sc8 (x4)



scn8 (x4)

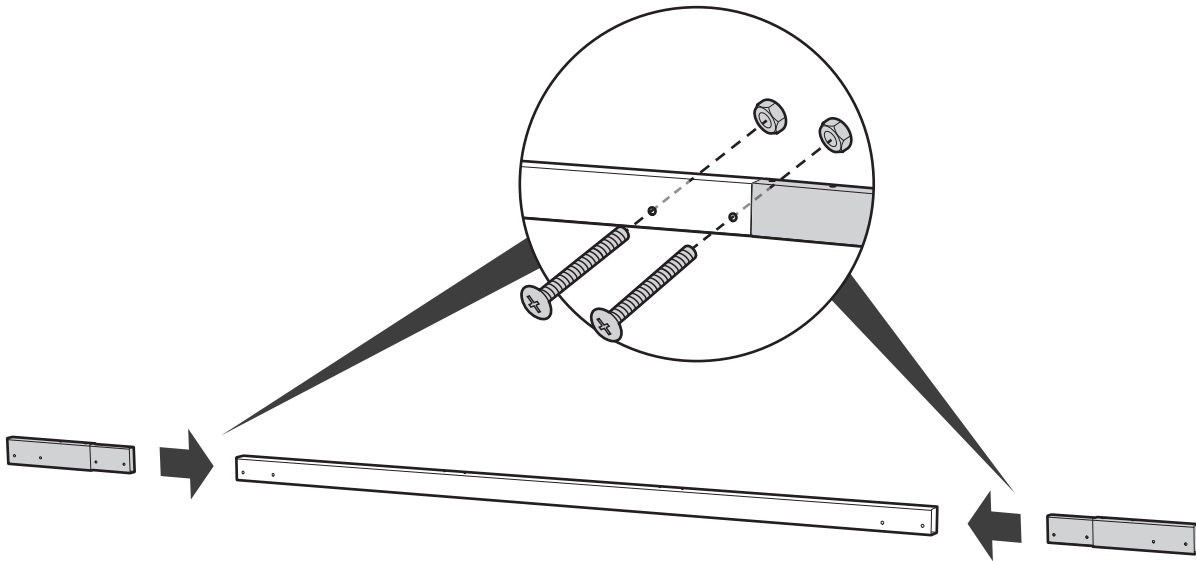

43



sc8 (x4)



scn8 (x8)

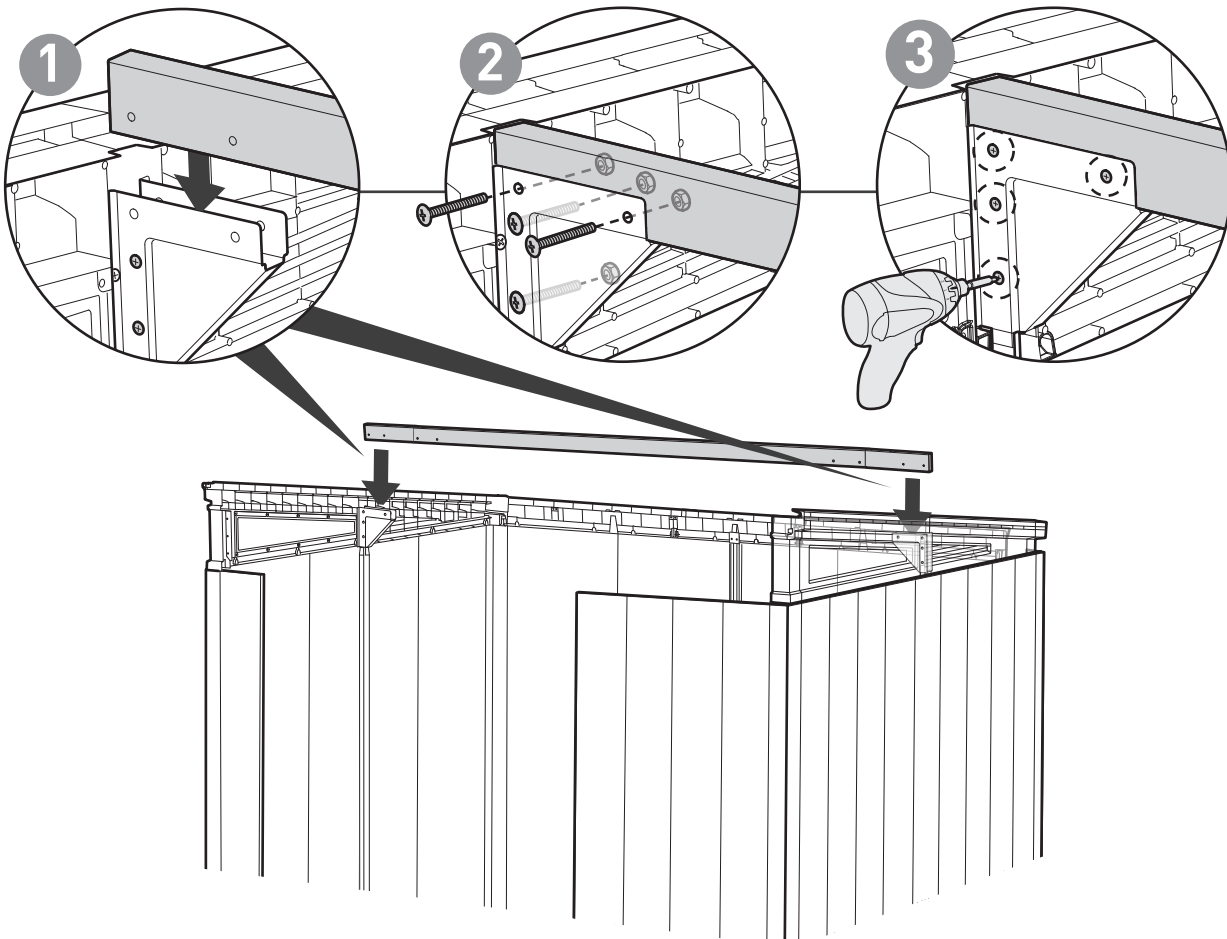



44



nELDP (x1)



nERDP (x1)

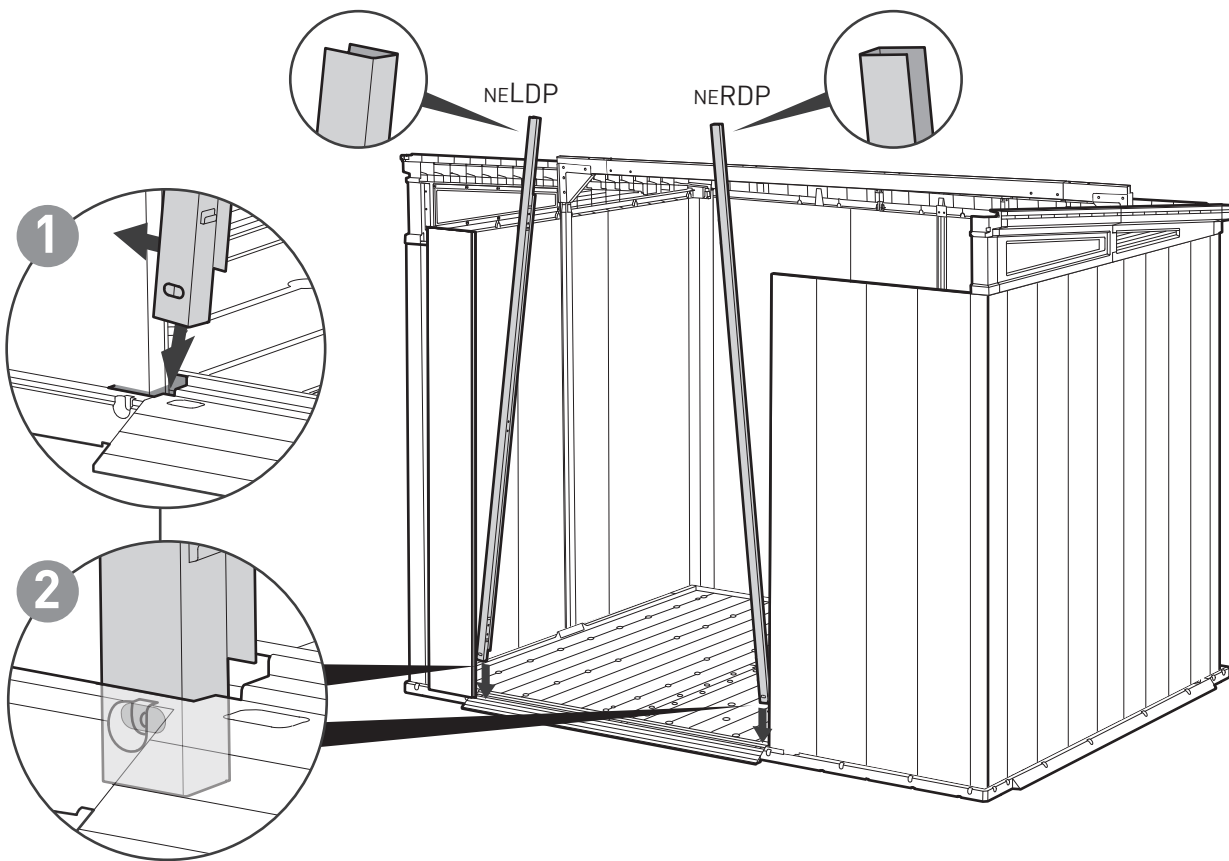

45

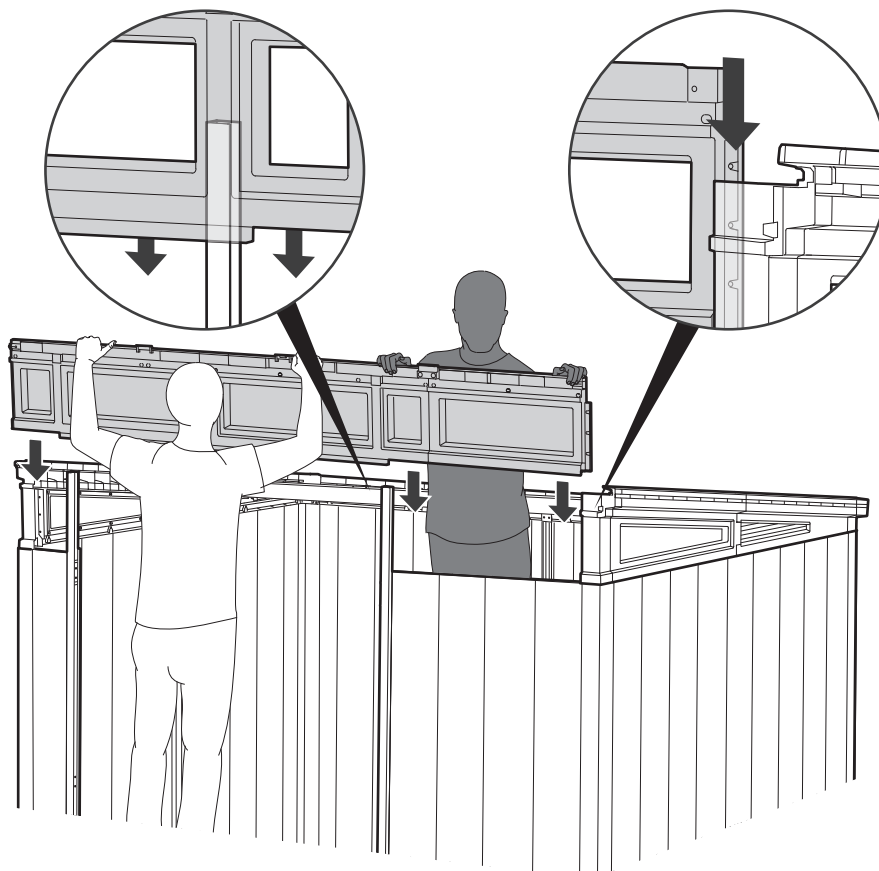
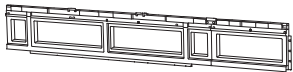

46

sc15 (x8)

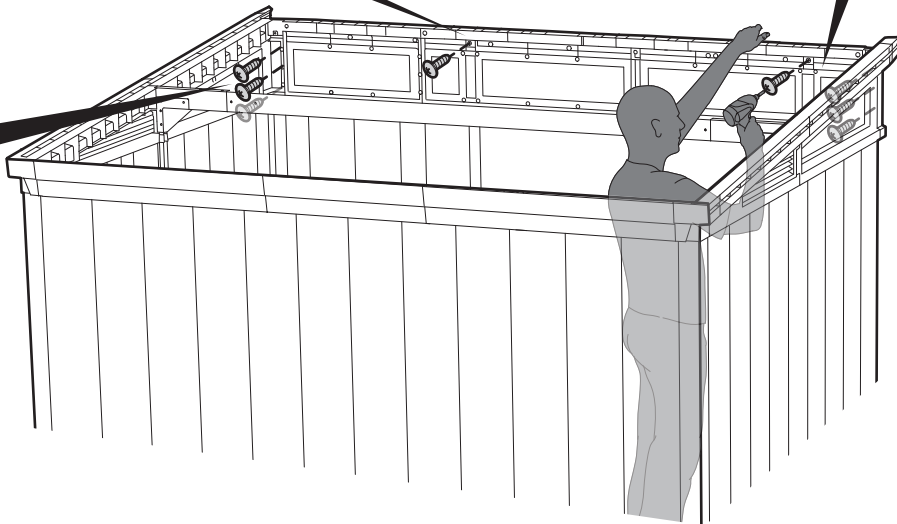
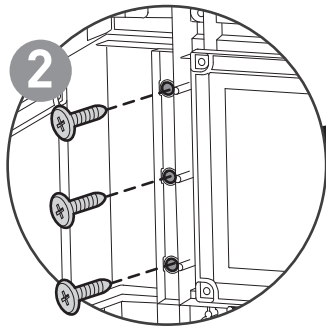
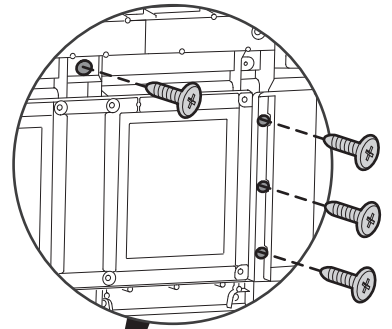
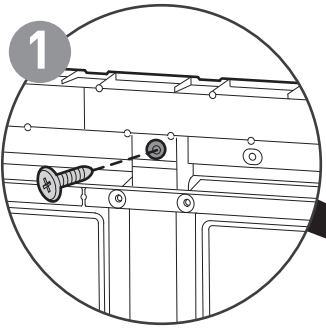

47

NERA (x3)

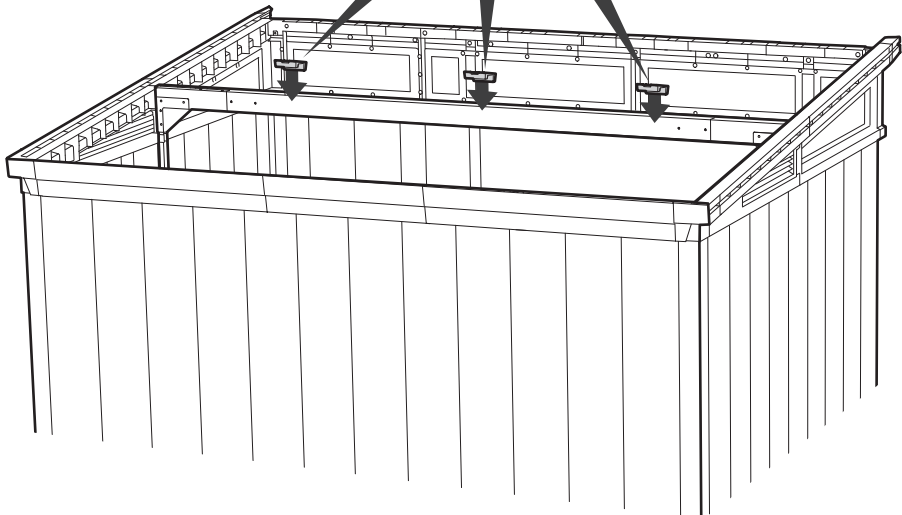
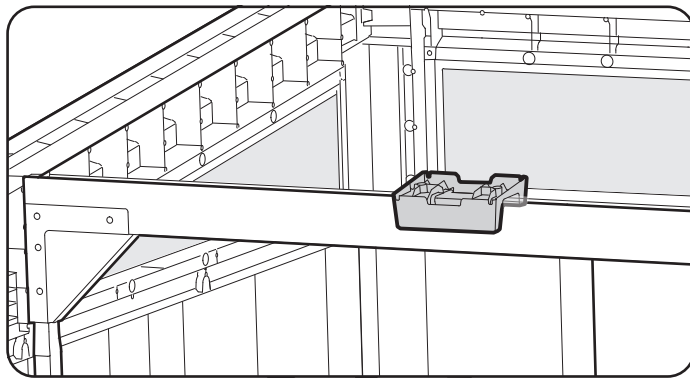
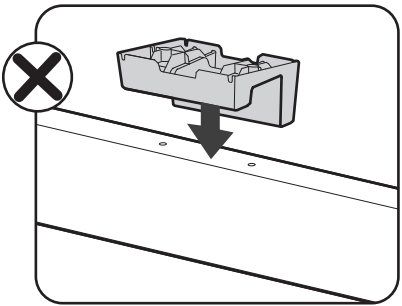
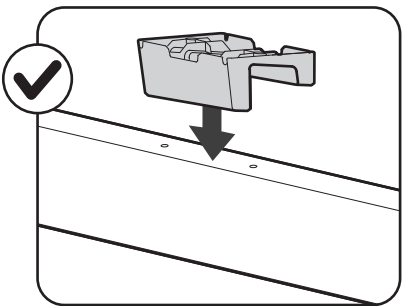

ROOF ASSEMBLY | 지붕 조립

48



NERM (x3)



sc15 (x18)

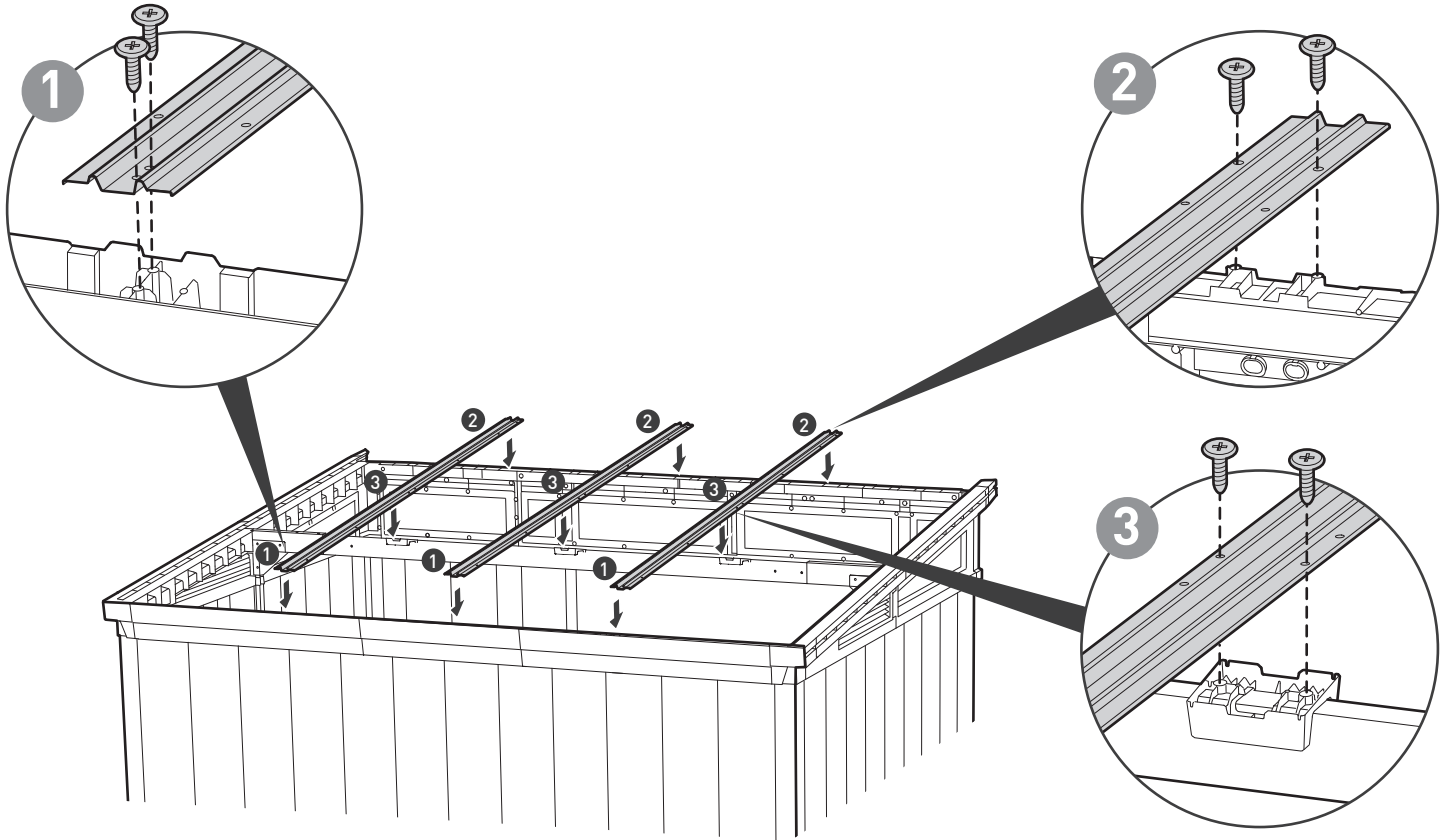

49



NEPRE (x2)

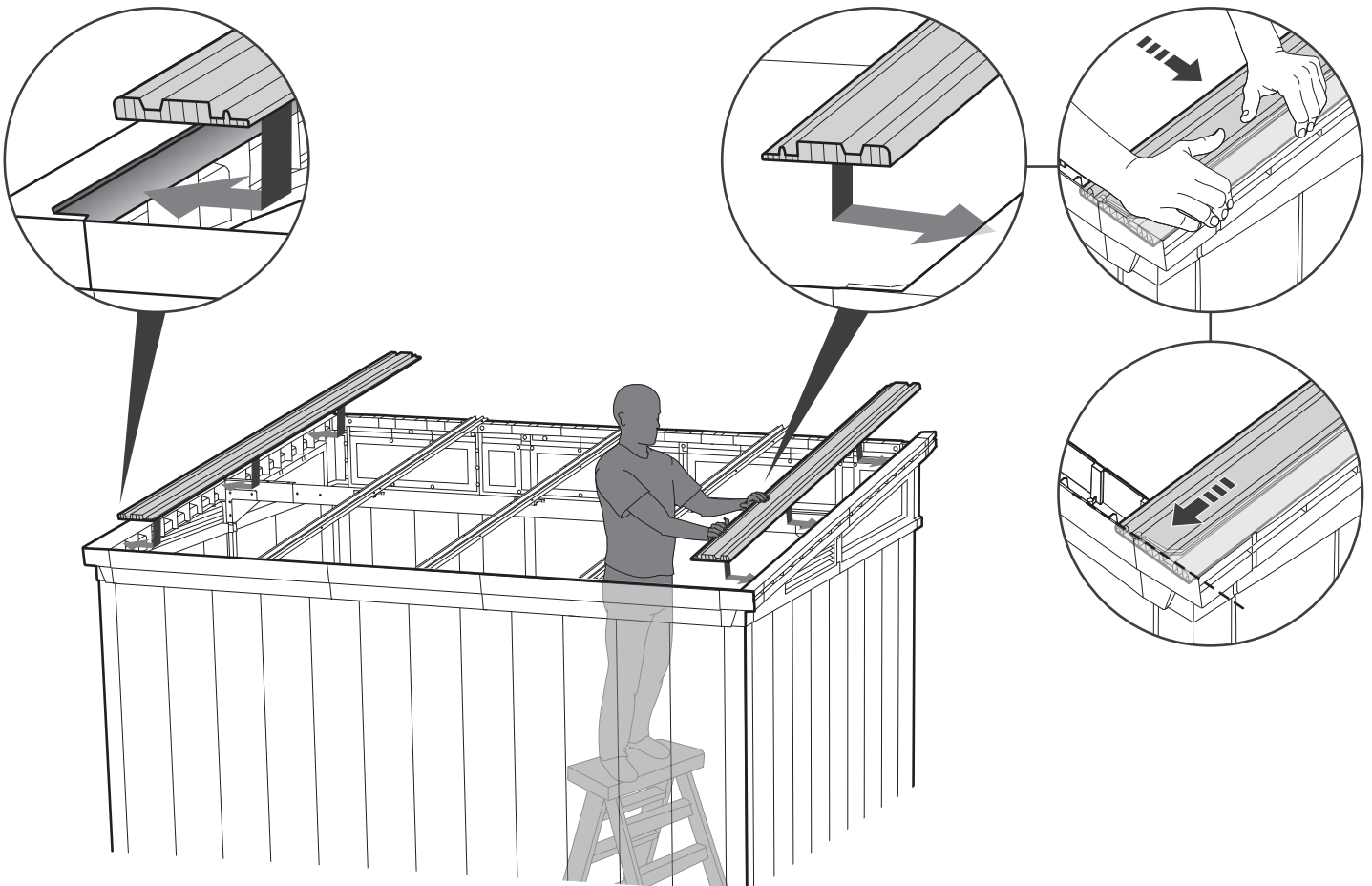



50



NEPR (x4)

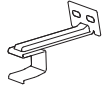

NERK (x4)

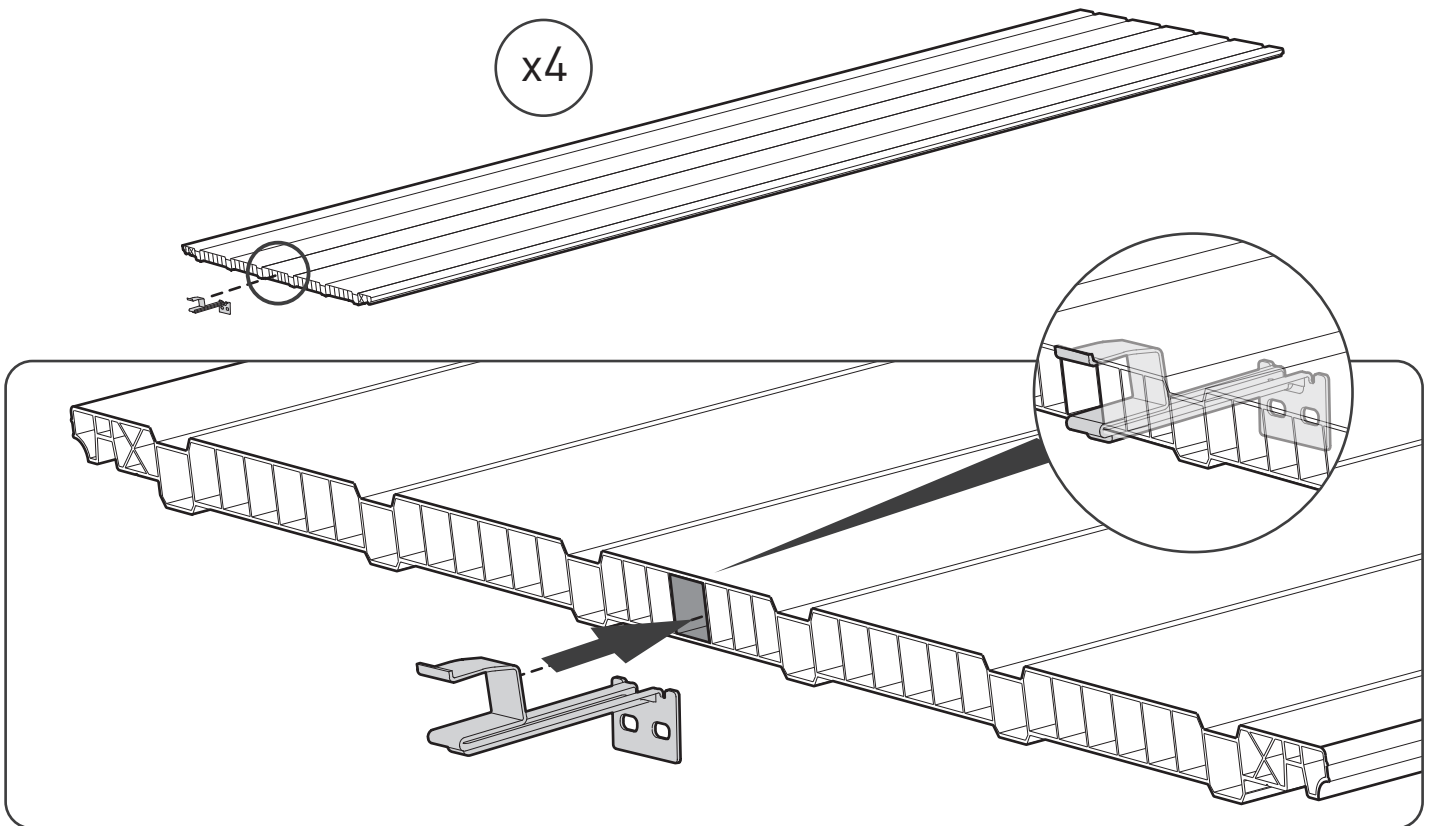

51



NEPR (x4)

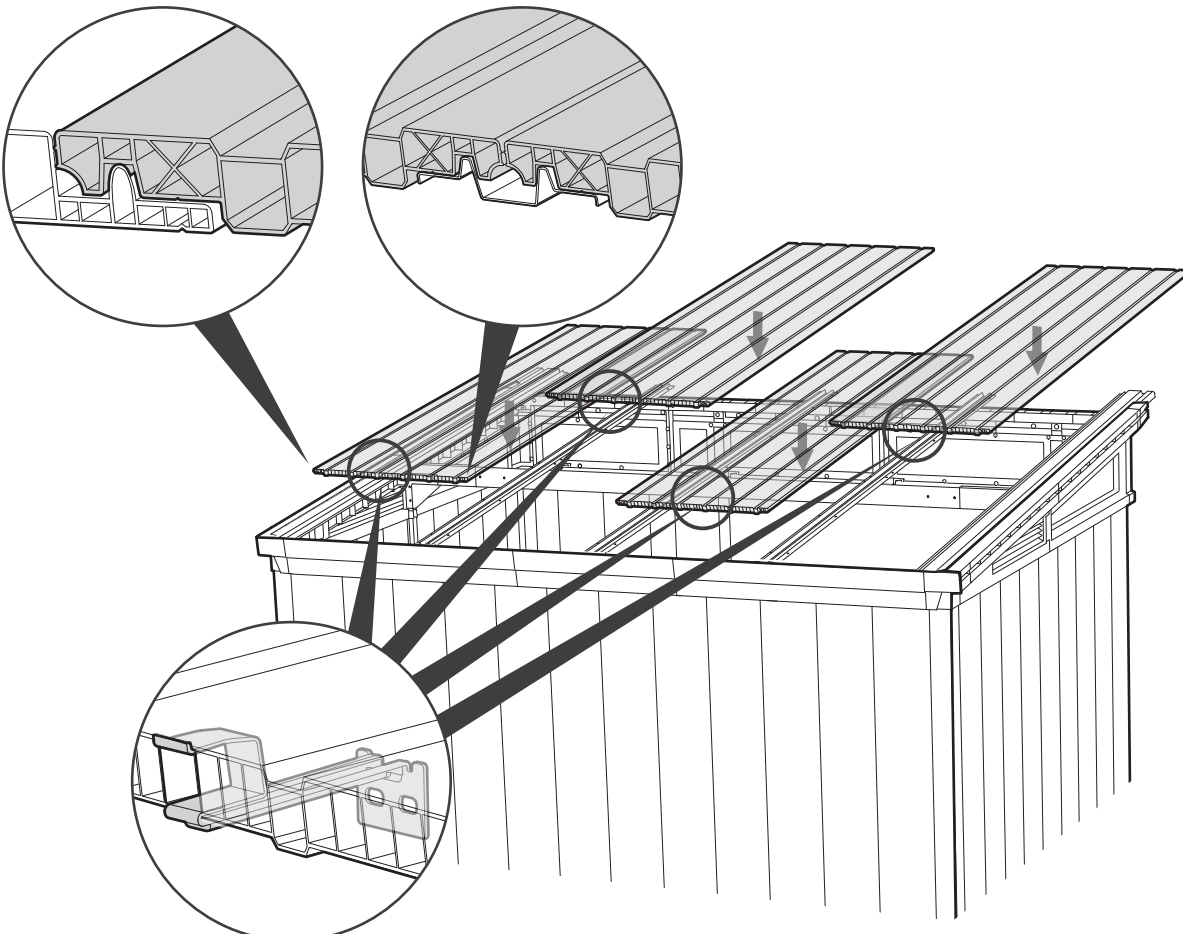

52

 sc15 (x8)

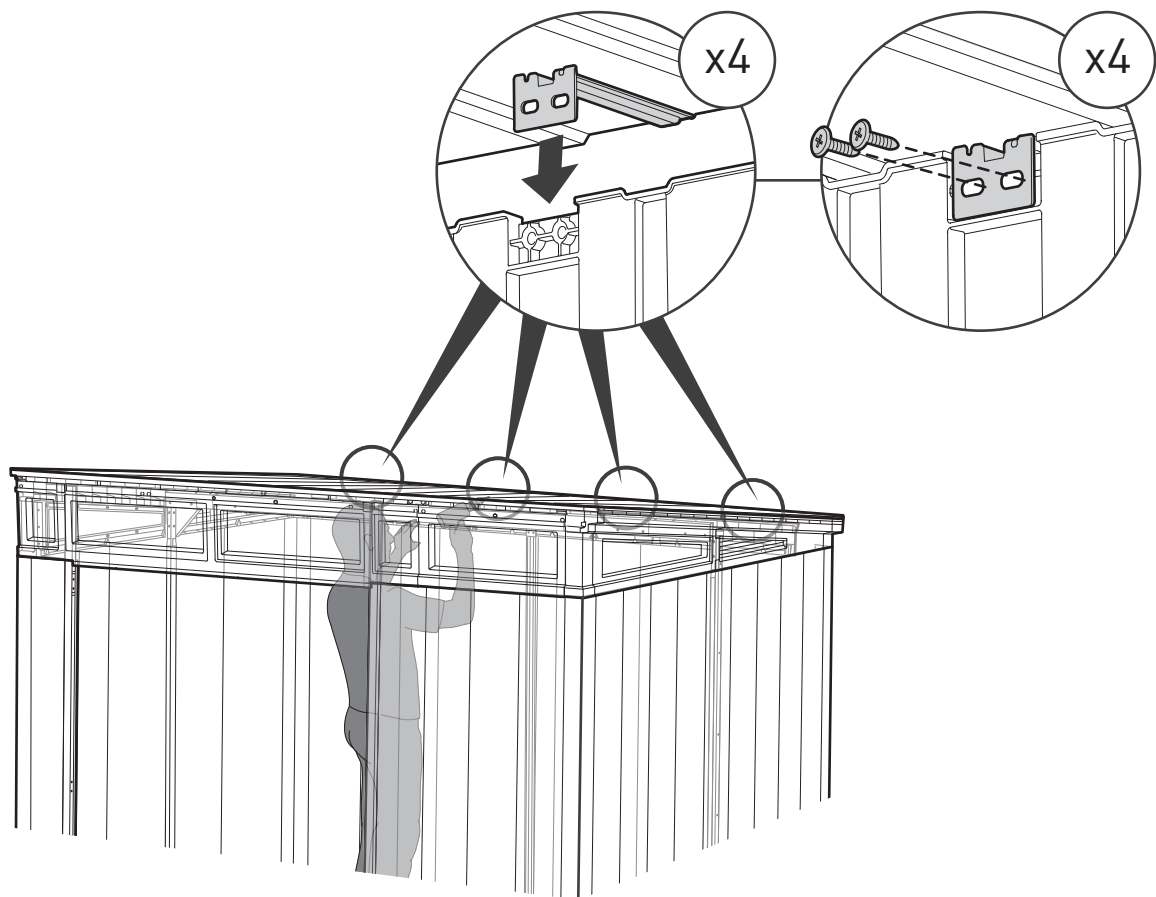

53

 NELC (x1) |  NERC (x1) |  NECE (x1) |  sc15 (x4)

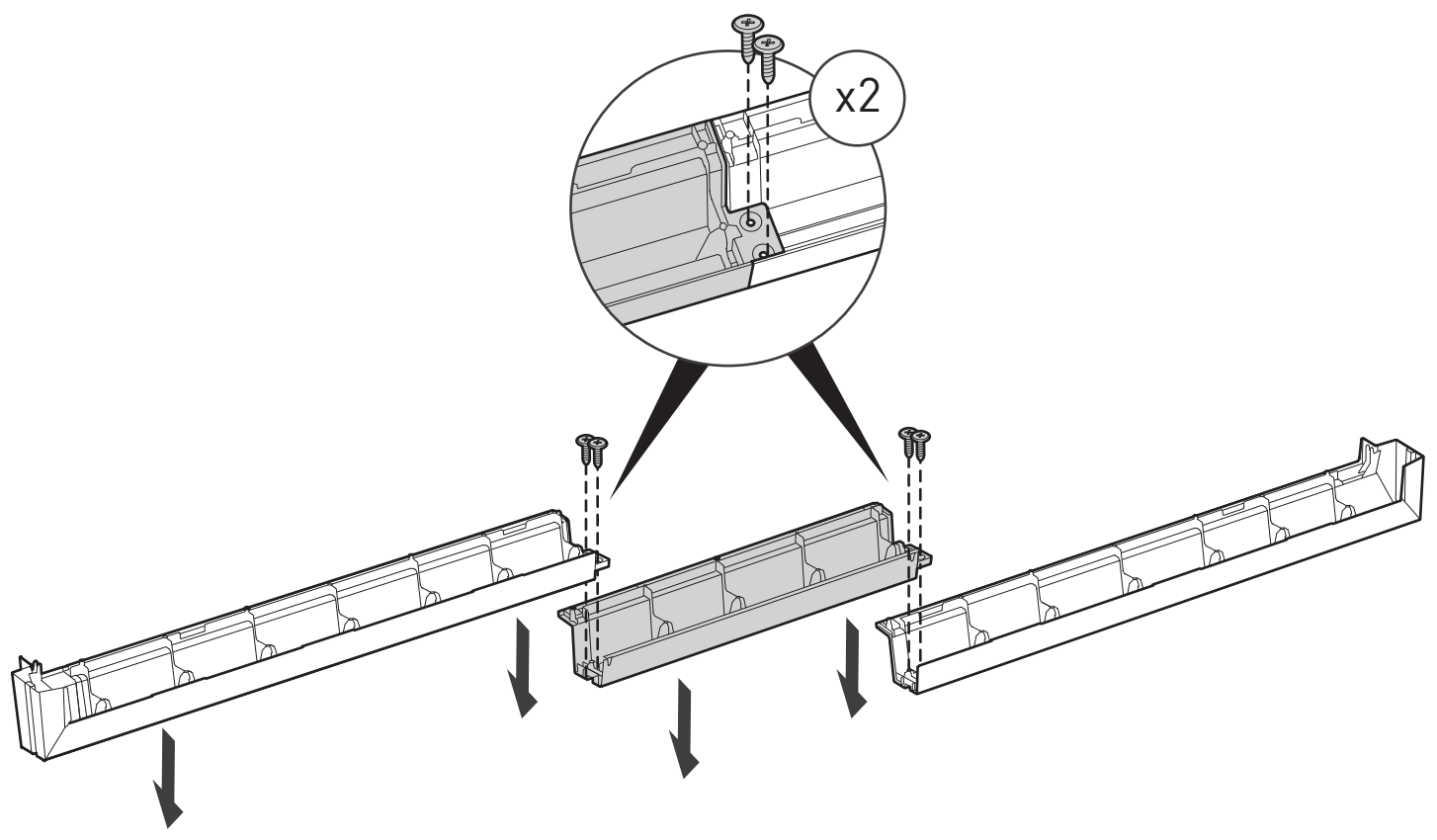



54

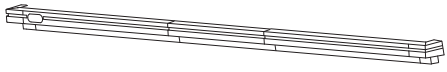

sc15 (x11)

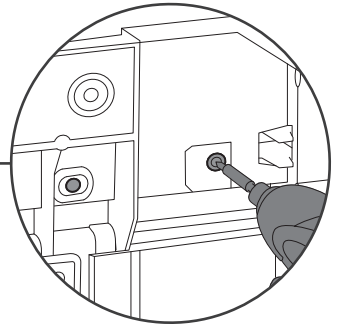
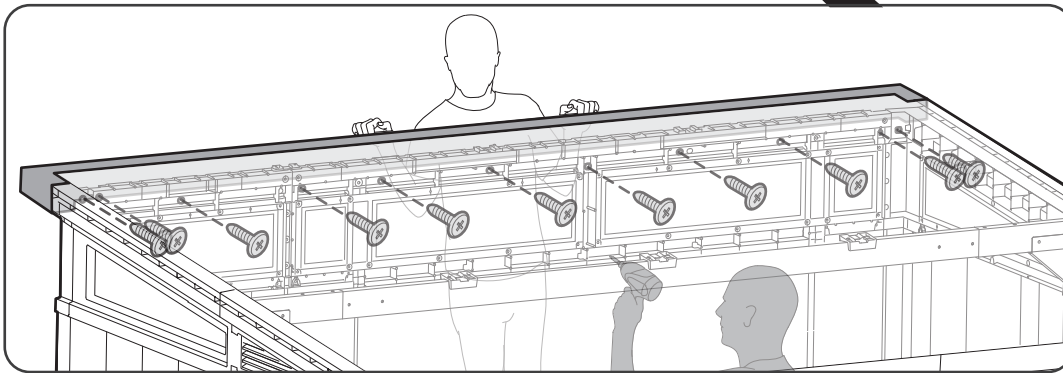
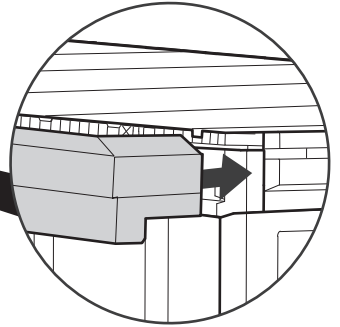
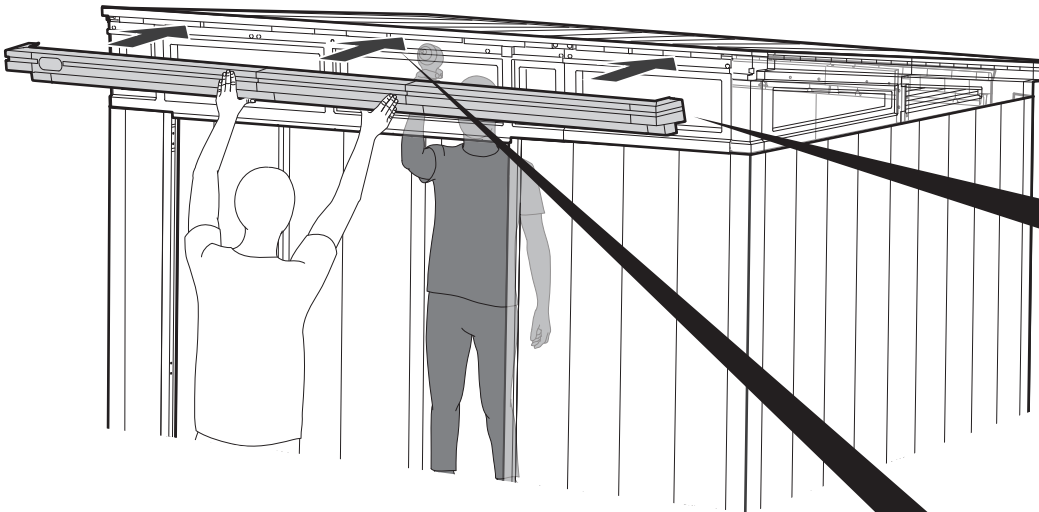

55



scw1 (x30)

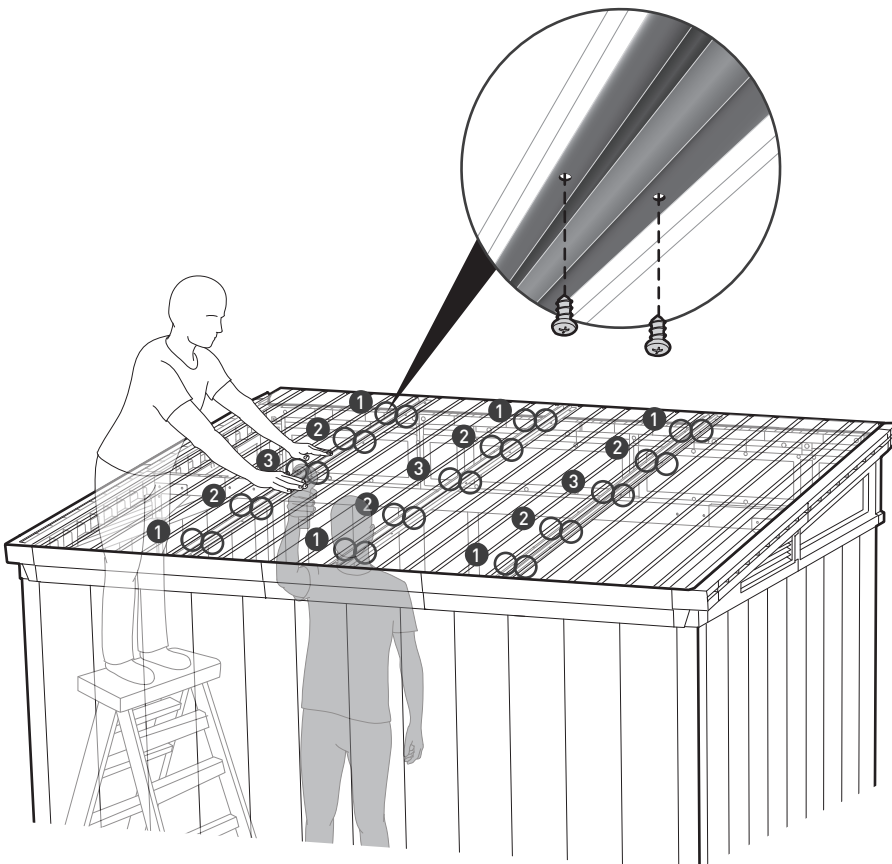



56



scw1 (x8)

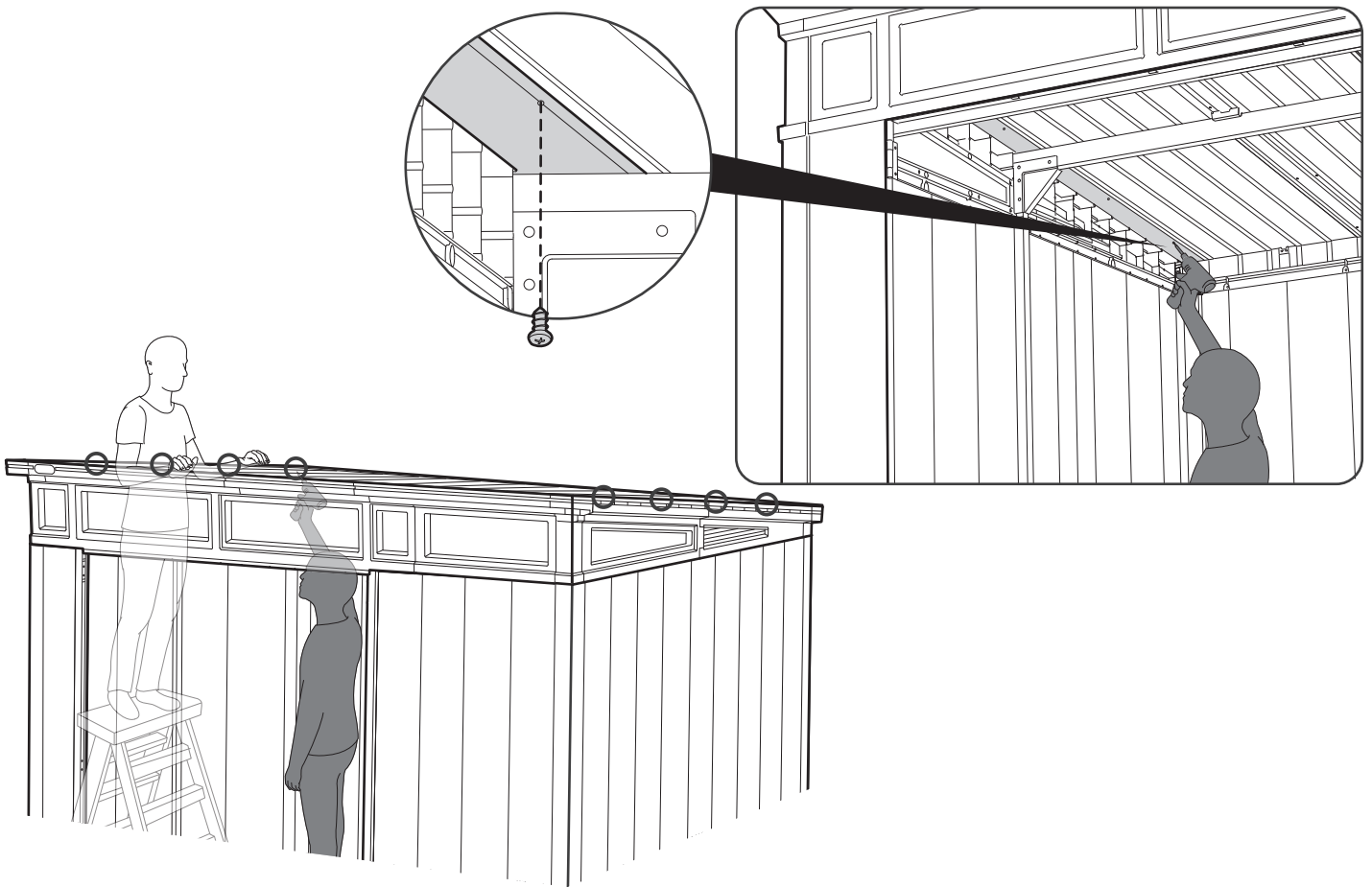



57

sc15 (x26)

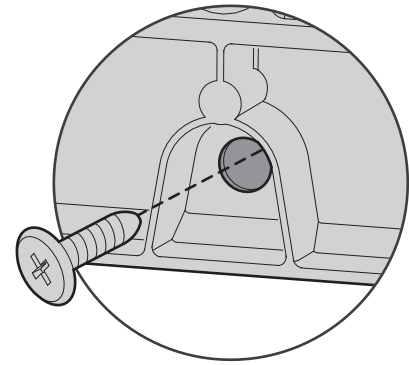
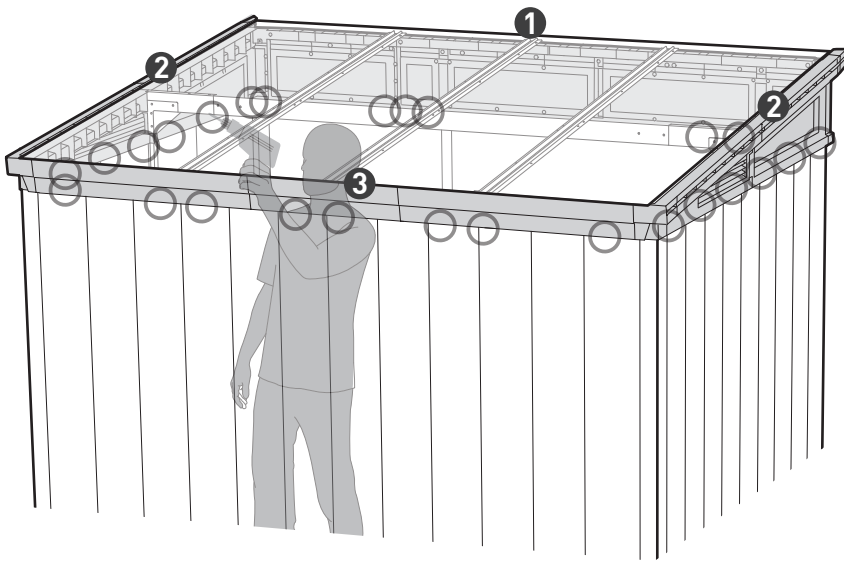

Front | 앞면

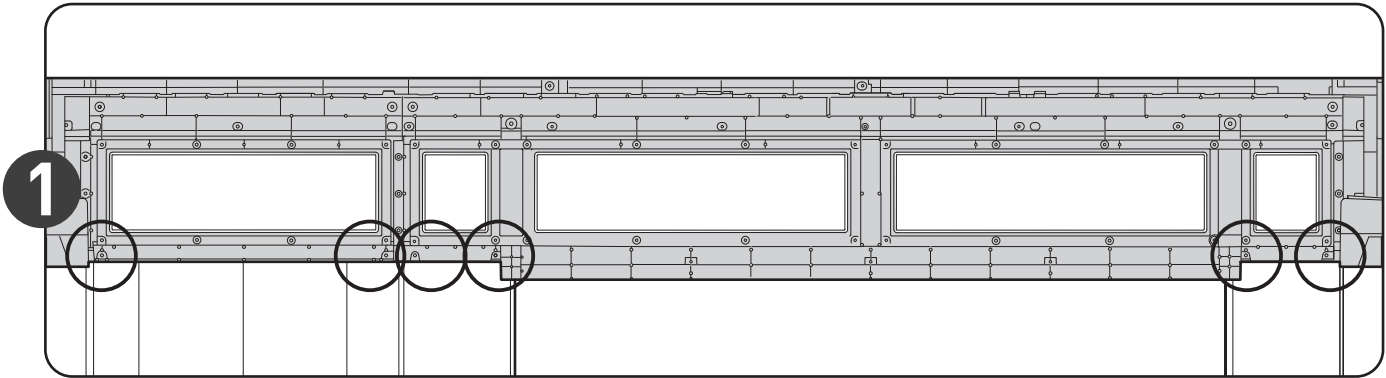

Right | 오른쪽
Left | 왼쪽

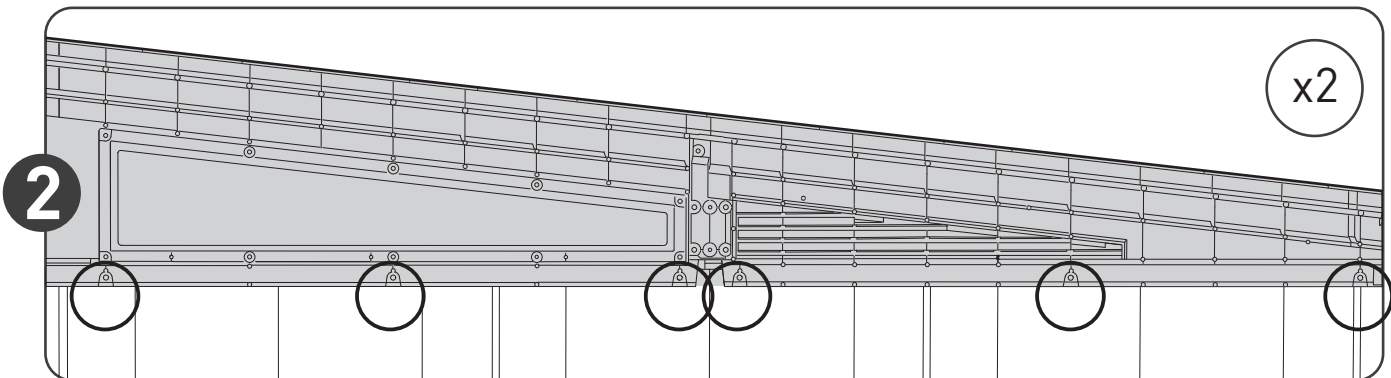

back 뒤쪽

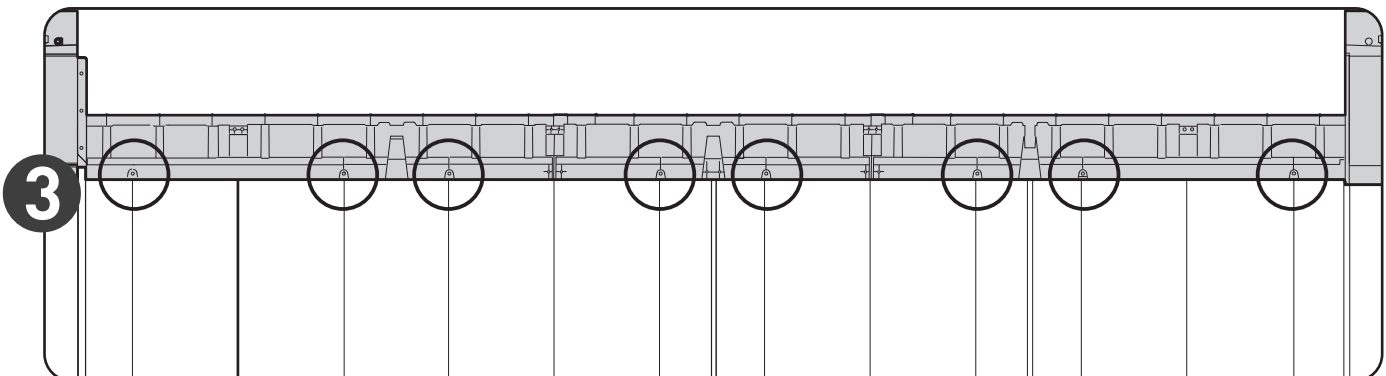



58

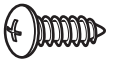

s13b (x15)

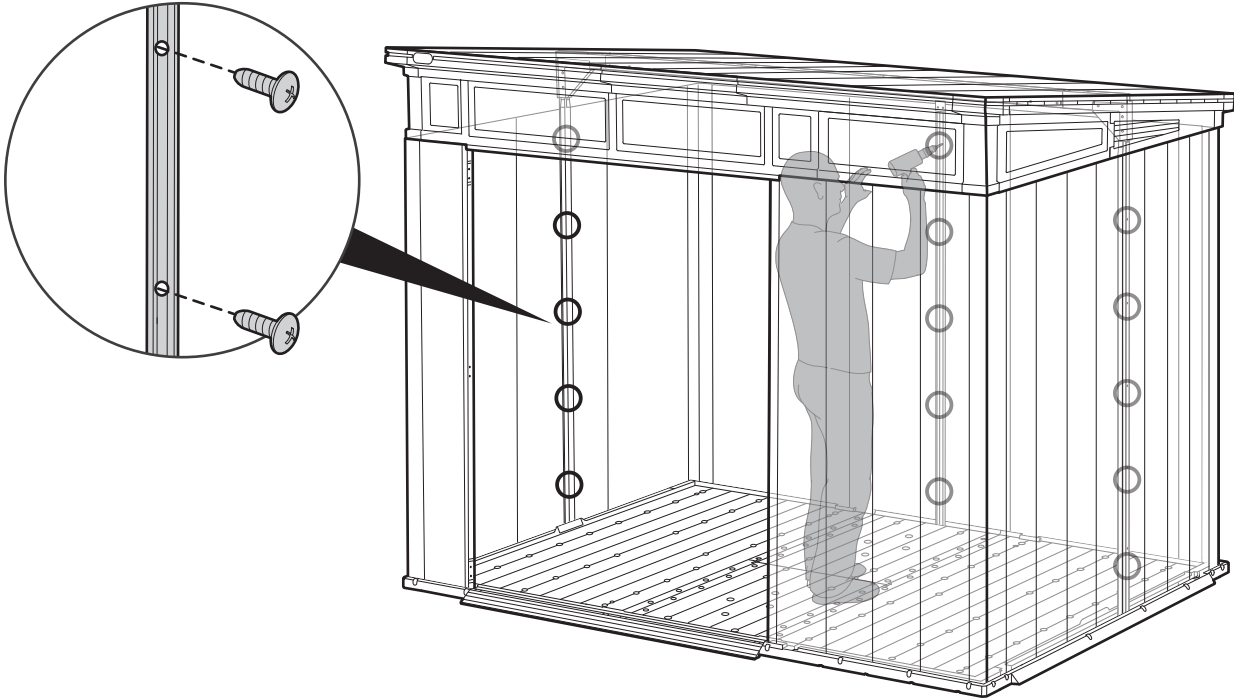

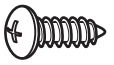

59

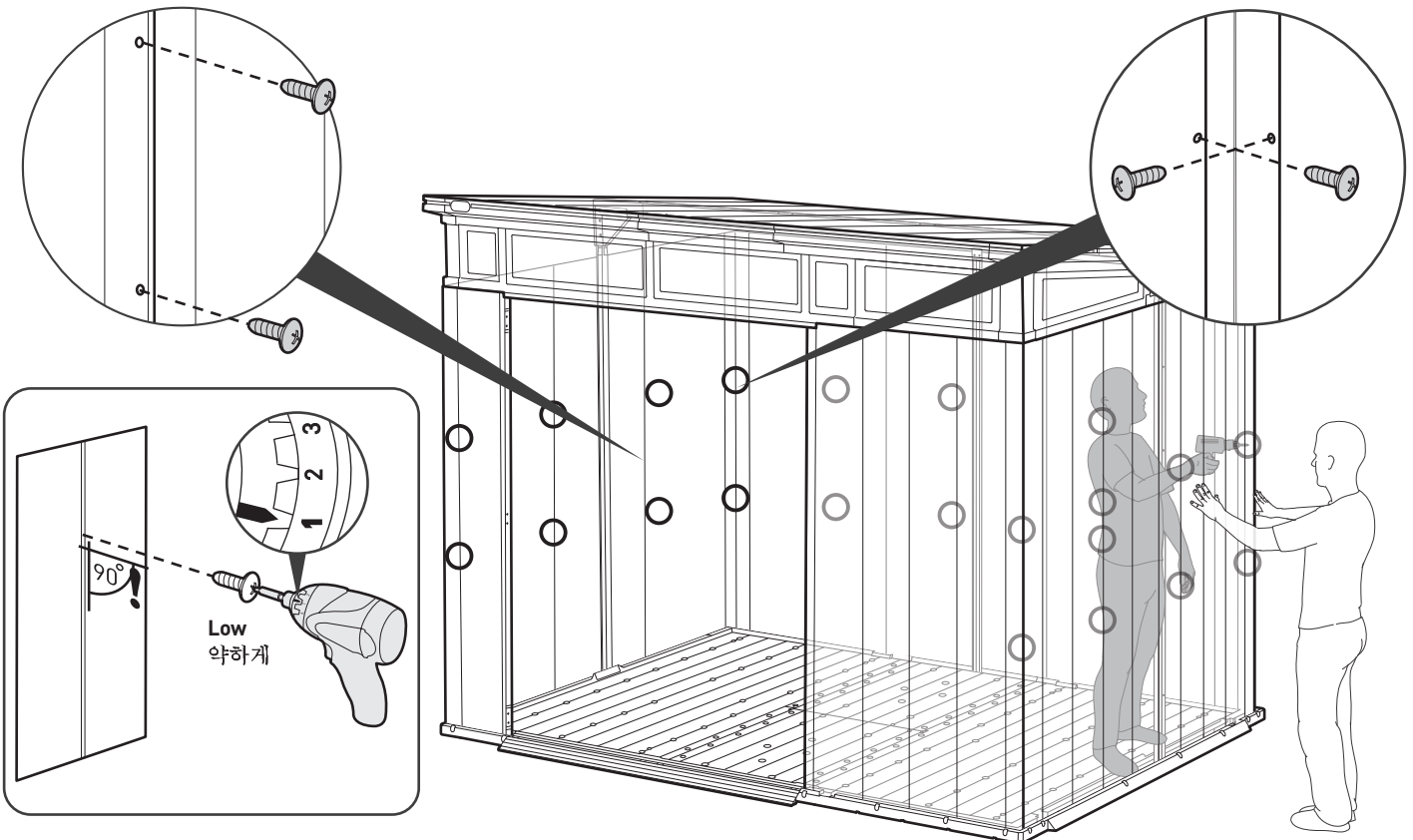

s13b (x30)



DOOR ASSEMBLY | 문 조립

60 |  NEDC (x4) |  NEDMC (x8) |  sf13 (x16)

x4

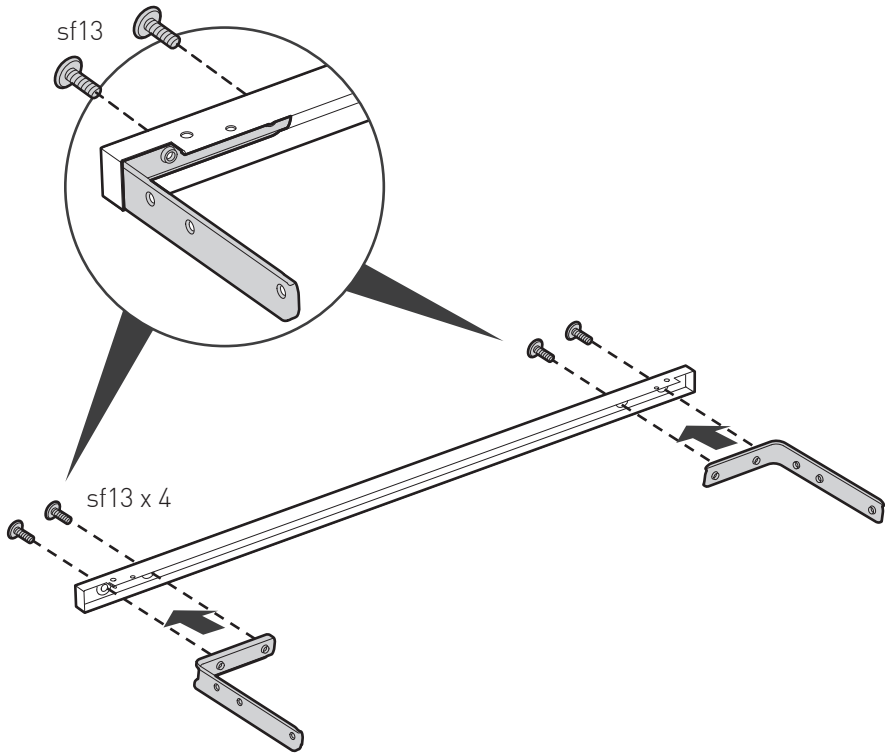

61 |  NUHF (x2) |  NEDOR (x1)

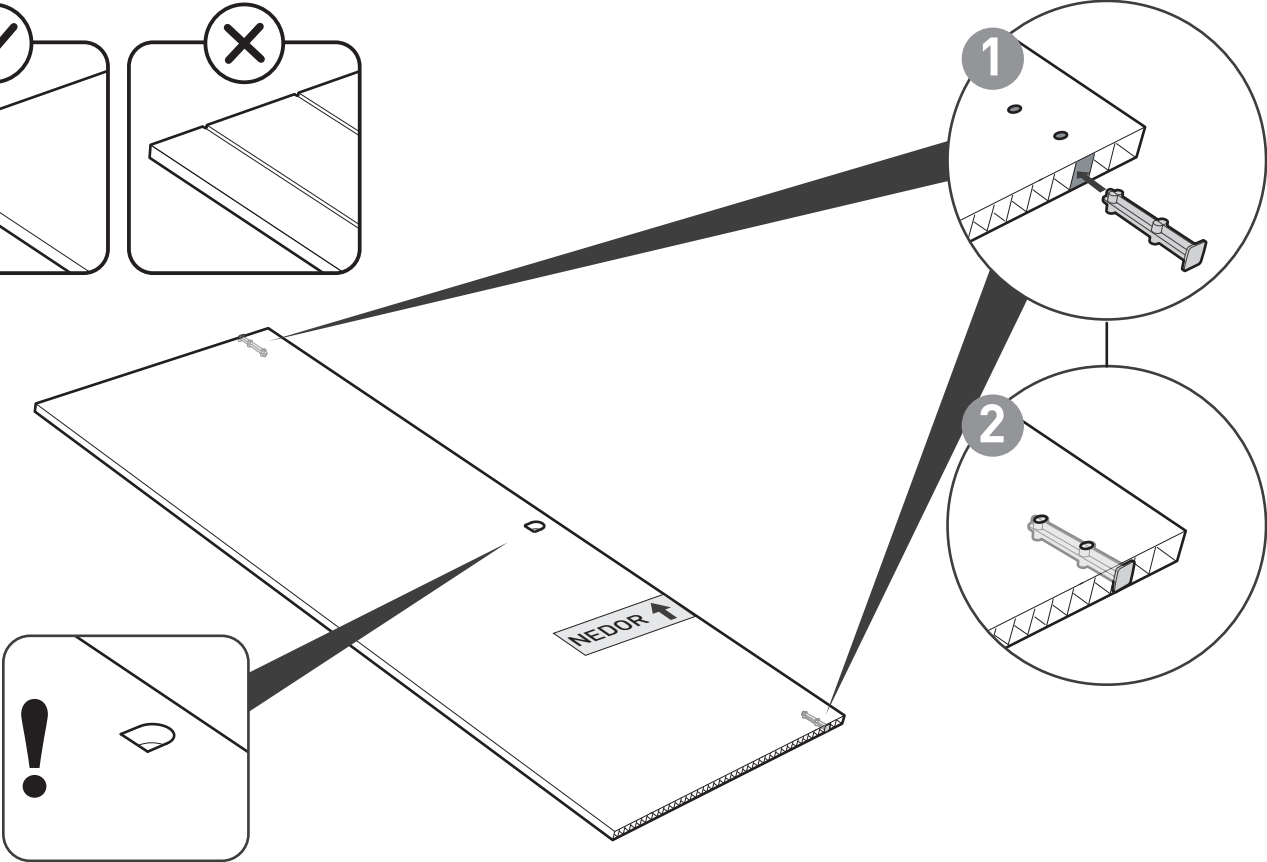
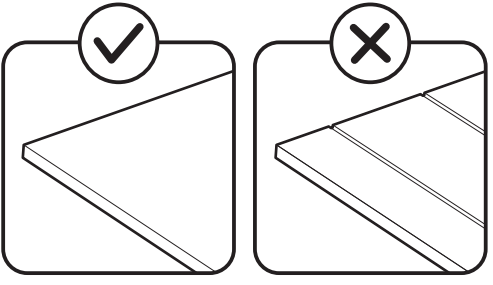



62



NE DOR (x1)



NE DOL (x1)

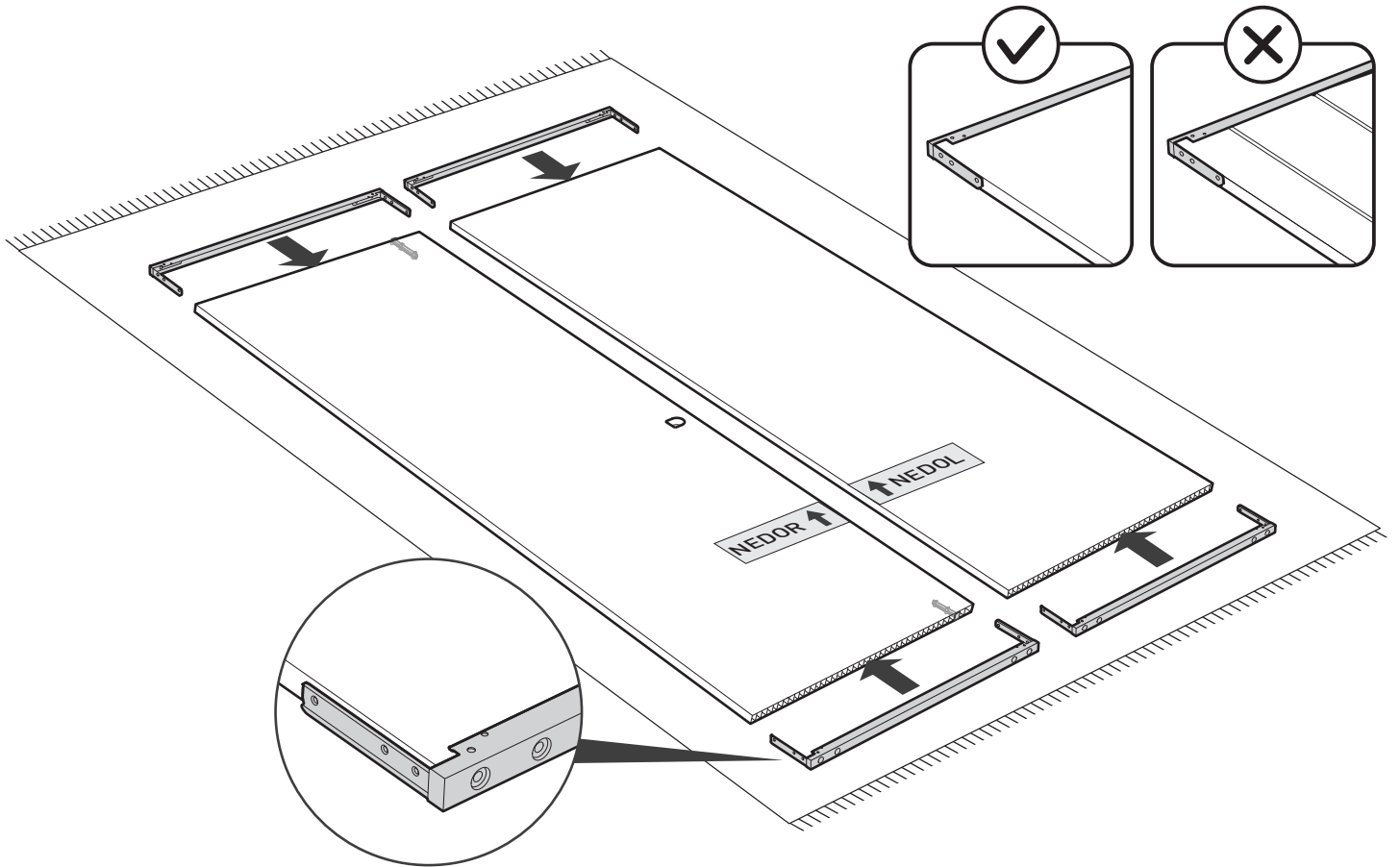

63



NE DSO (x2)



NE DSI (x1)



NE DSW (x1)

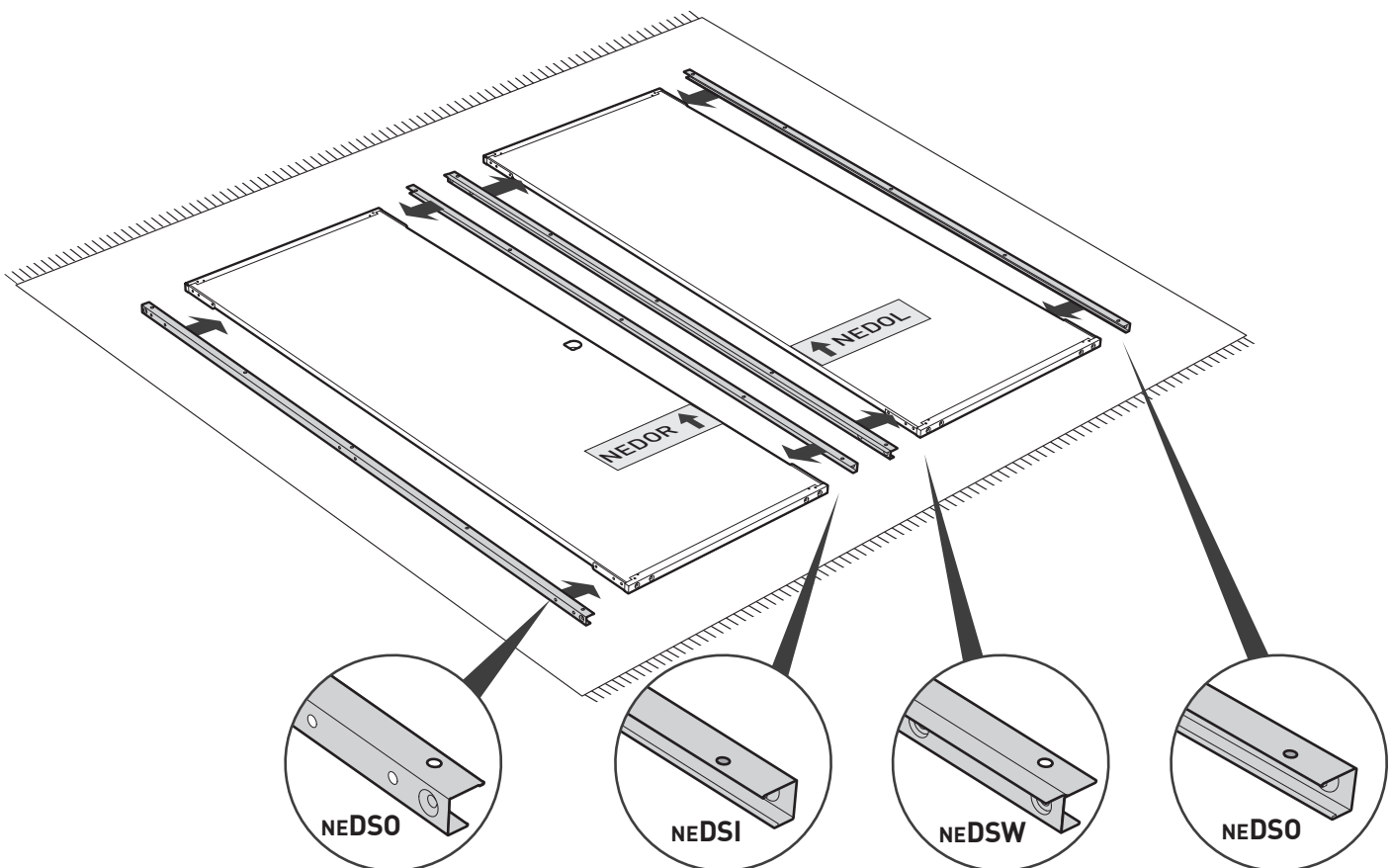



64

sc15 (x12)

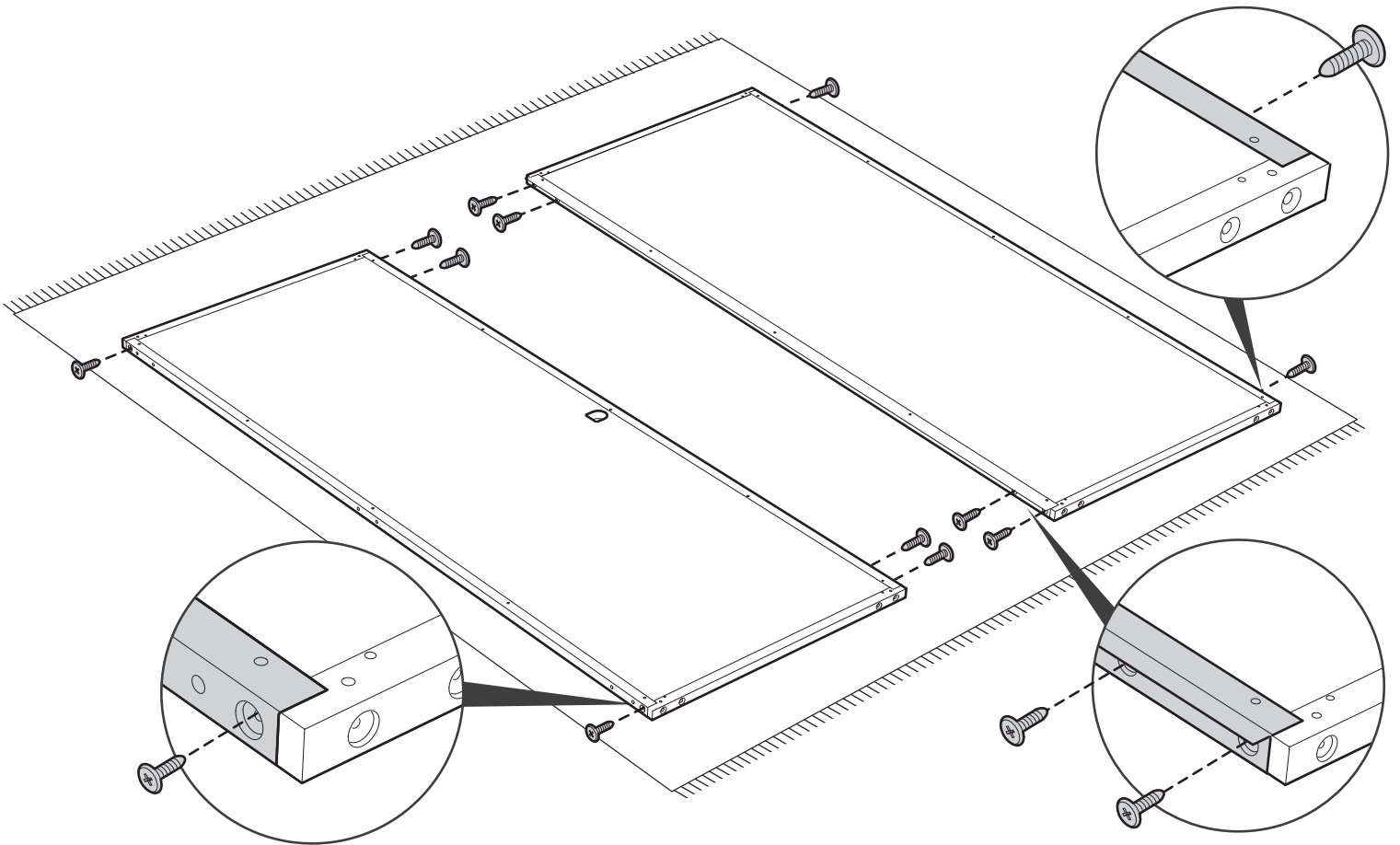

65

nuHG (x2)

NUHH (x2)

sc15 (x4)

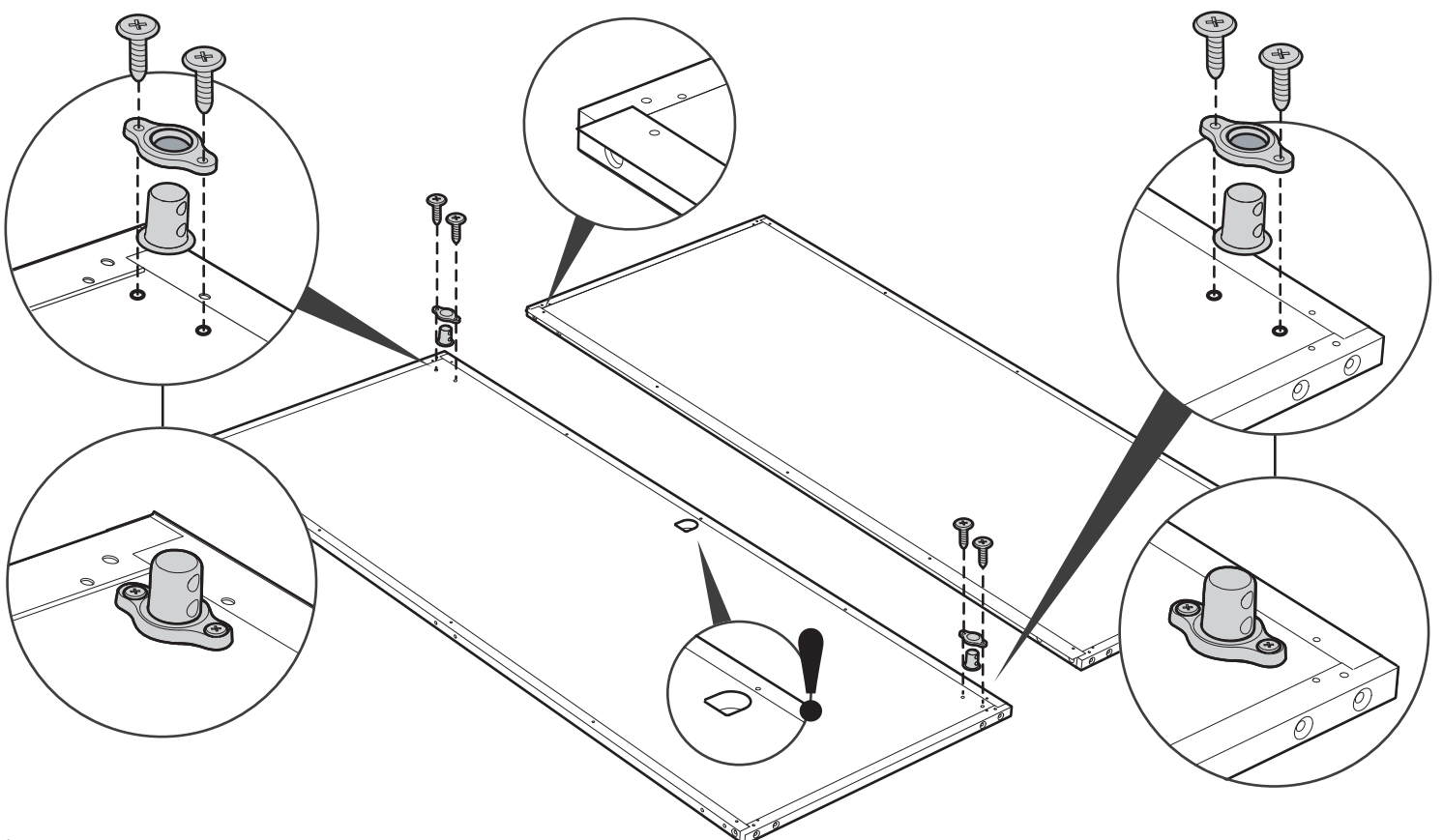



66

!  s13b (x28)

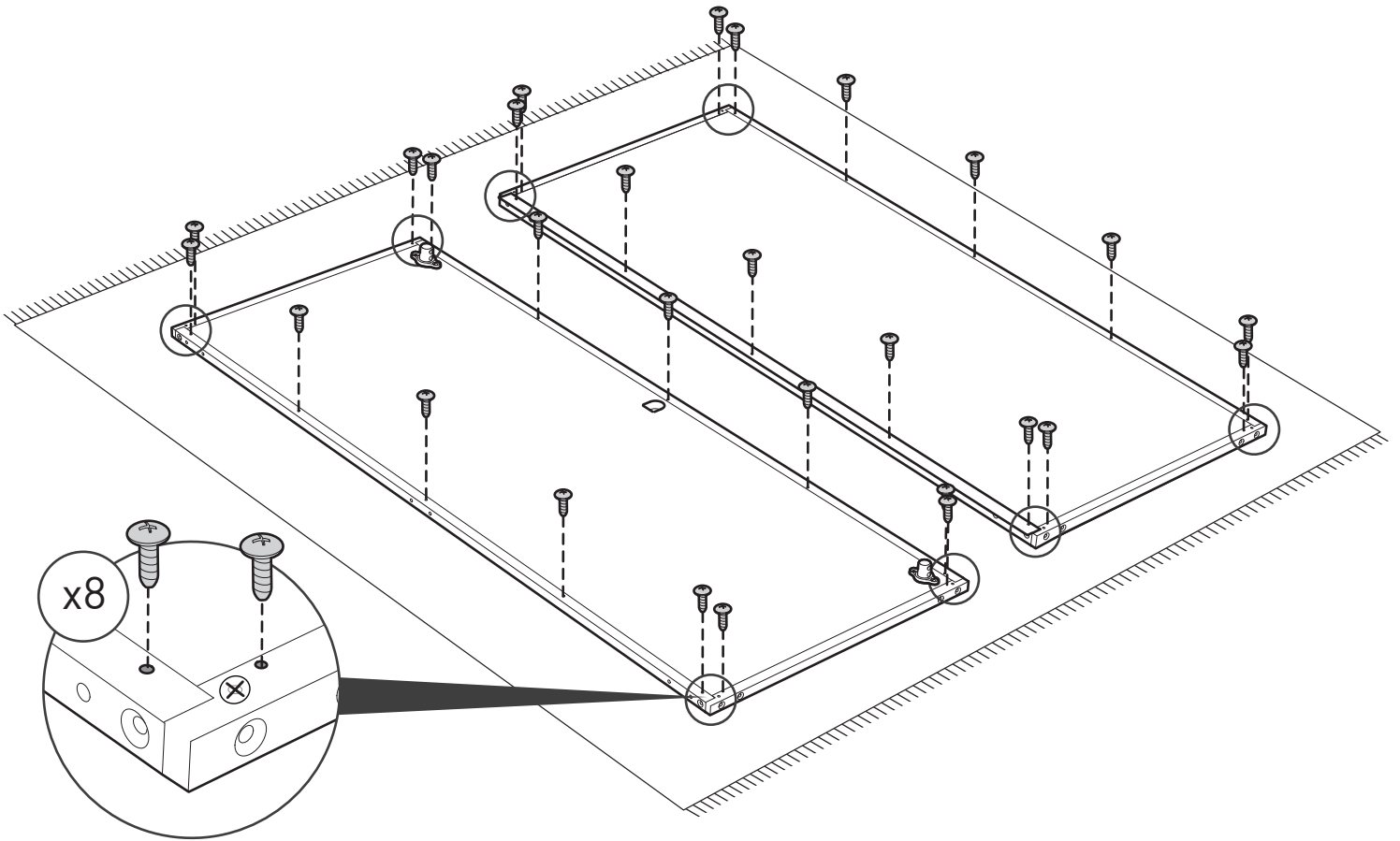

67

 NEDH (x6)

 sc15 (x12)

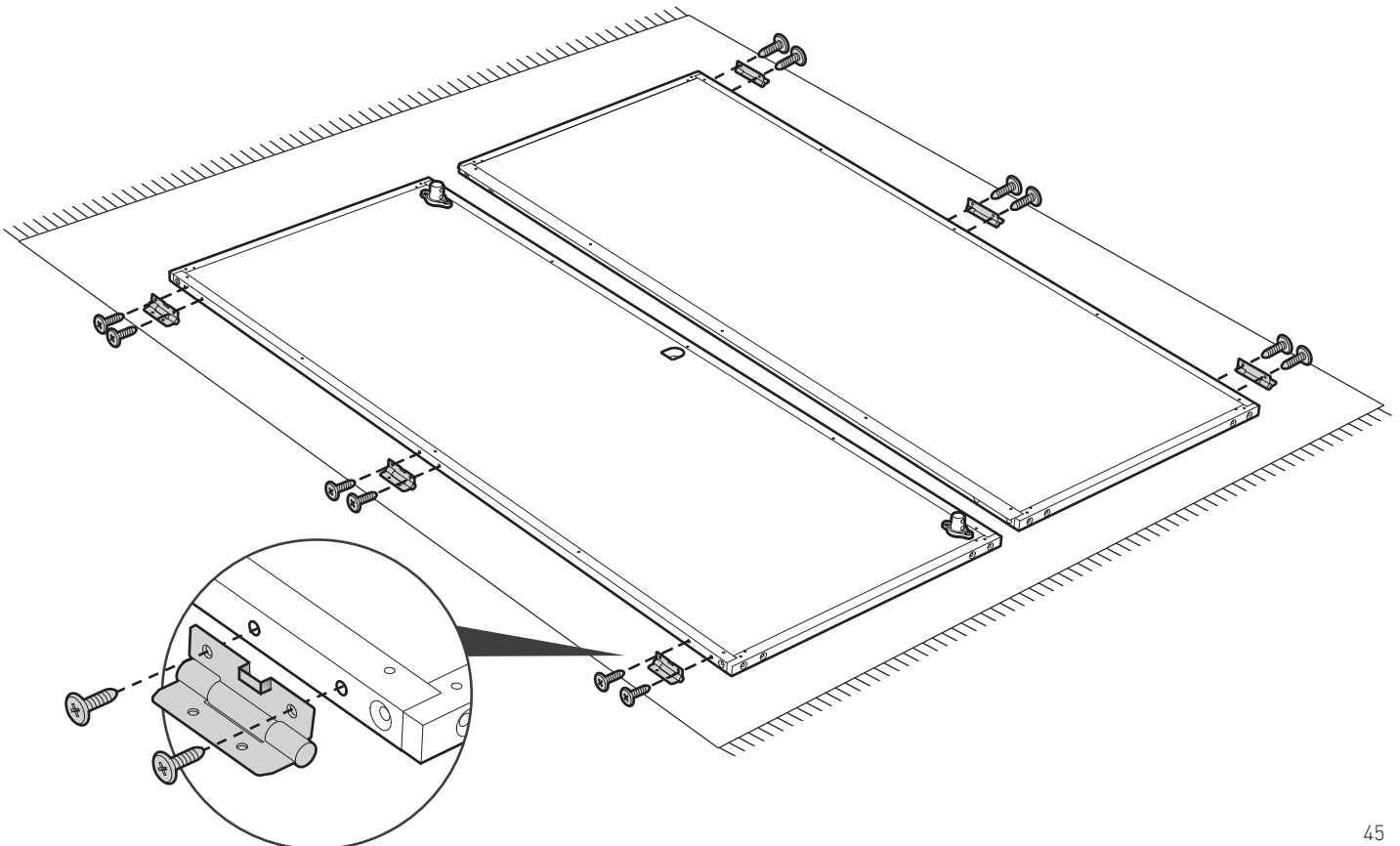

68

sc7t (x12)

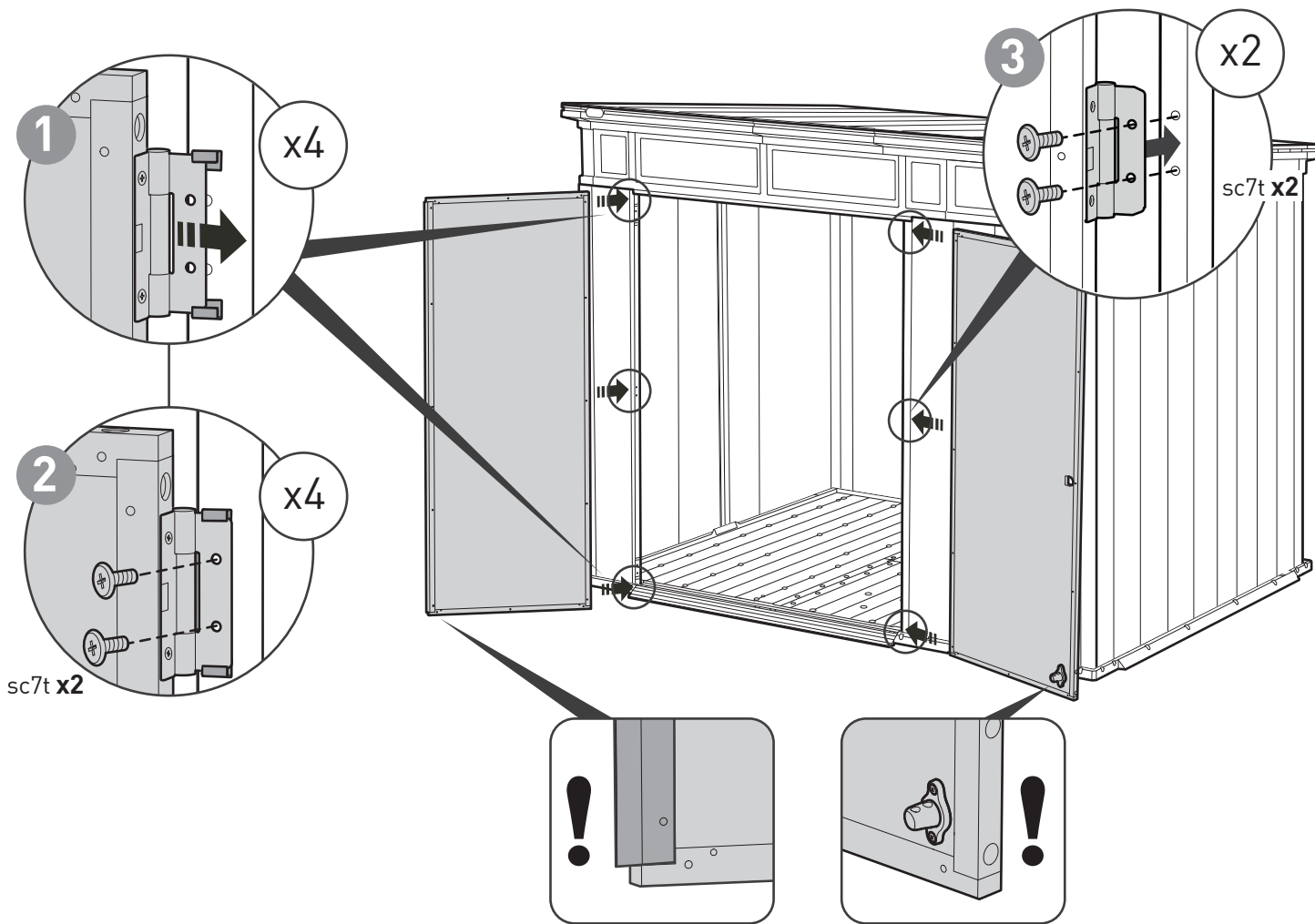

69

NUHB (x1)

NUHA (x1)

NUHC (x1)

NUHD (x1)

sc8 (x1)

scn8 (x1)

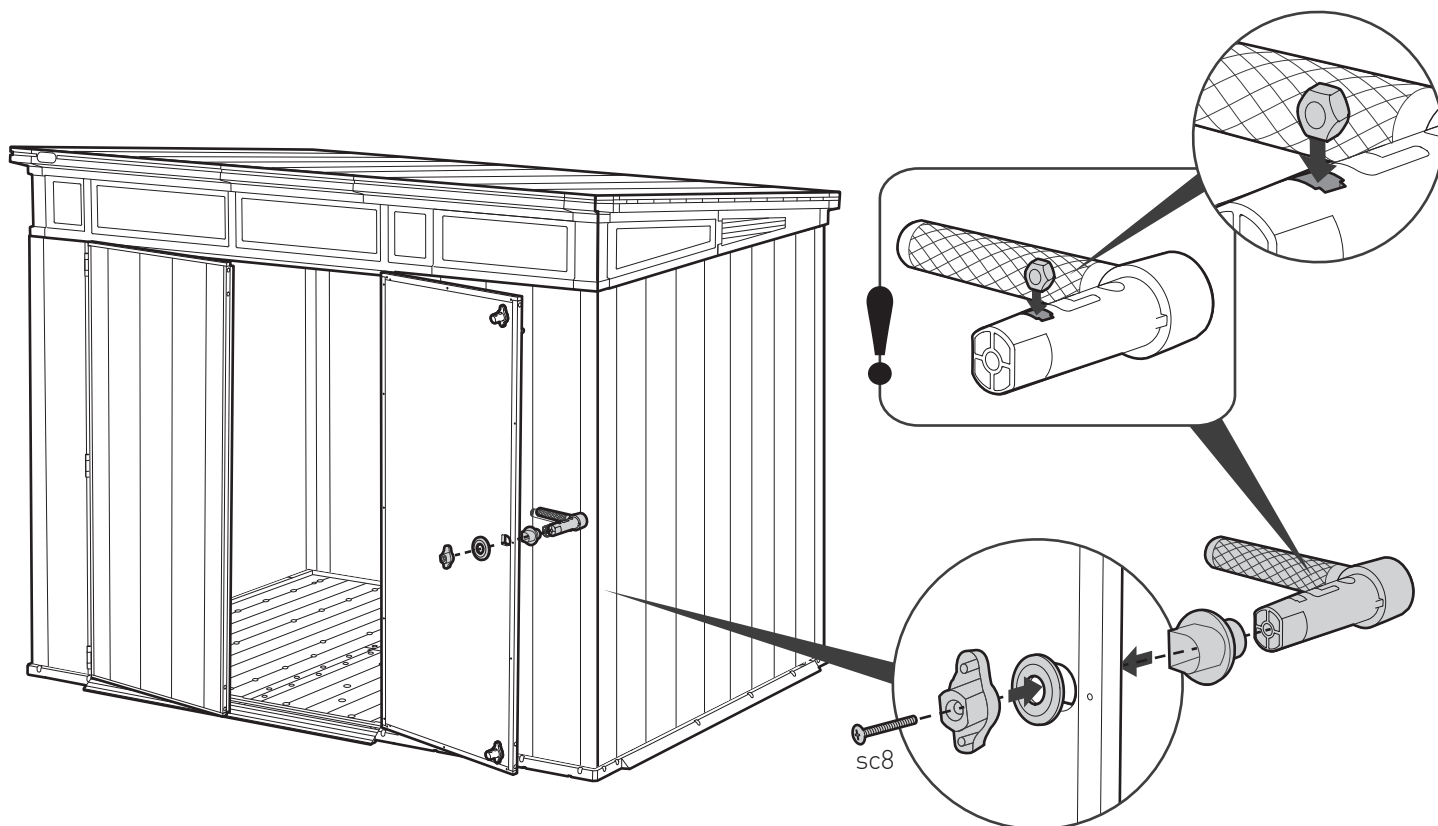

70



NUHE (x1)



NEMB (x2)



sc15 (x2)

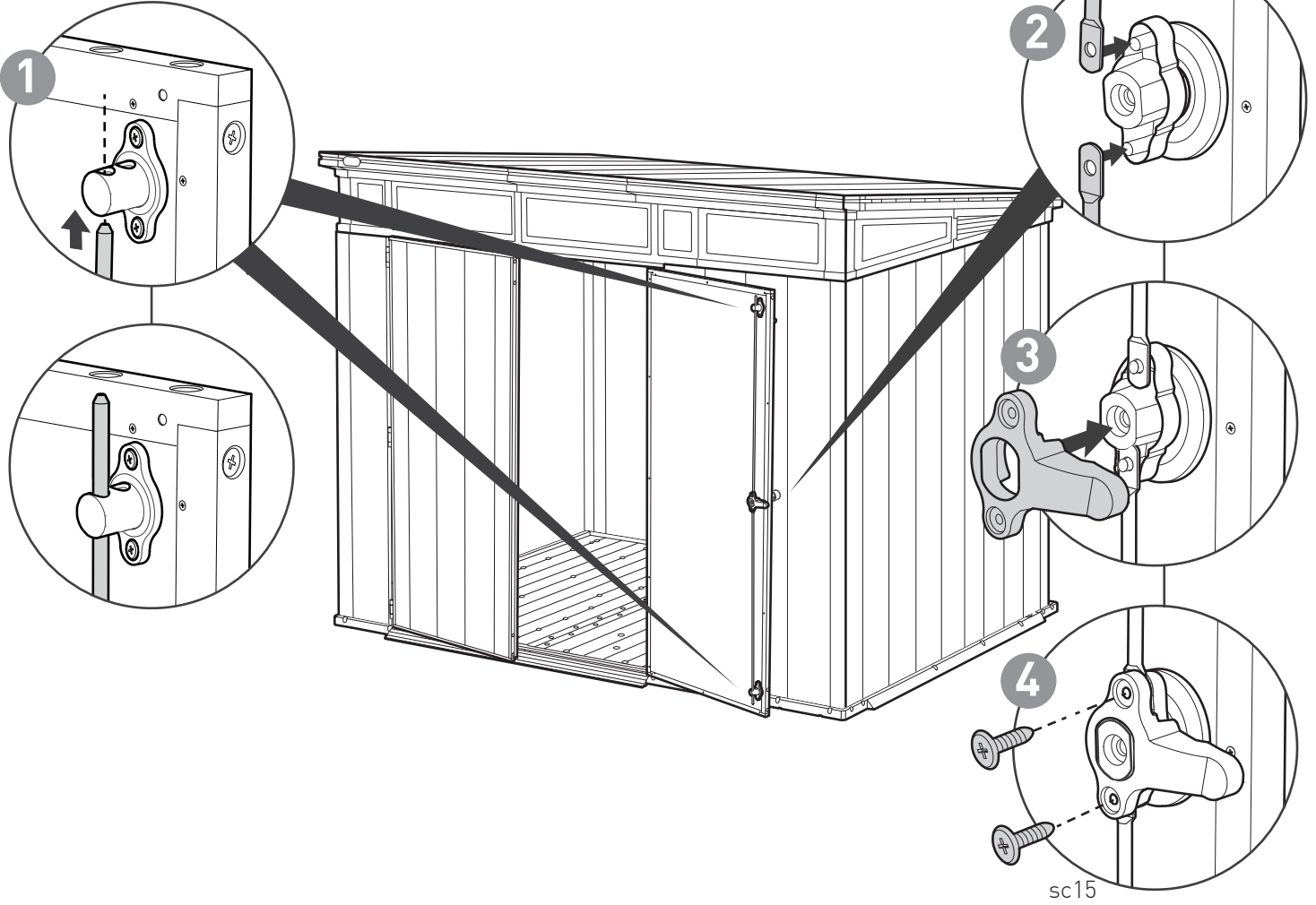

71



s45b (x30)

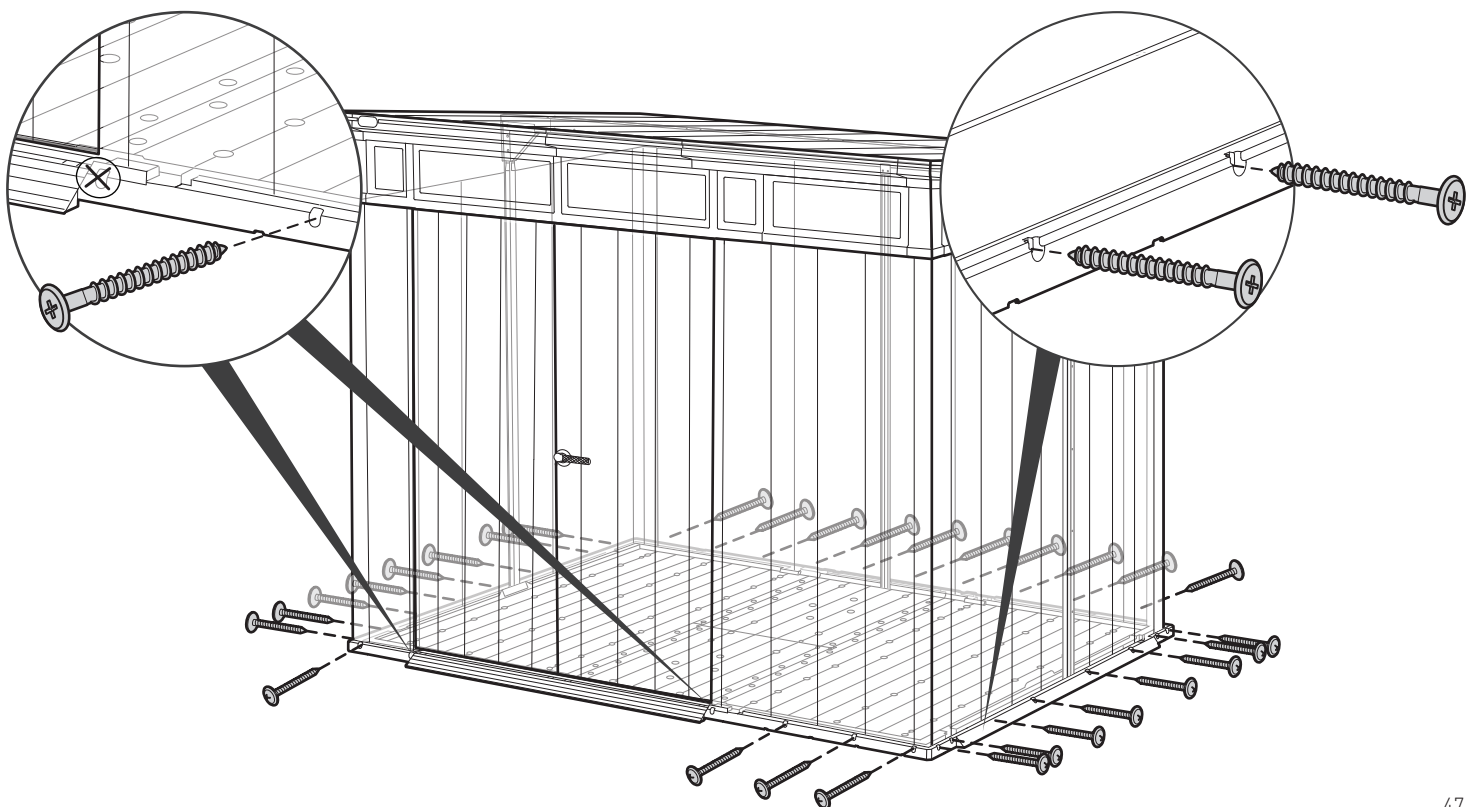



72



NE DPC (x2)



sc15 (x4)



s45b (x2)

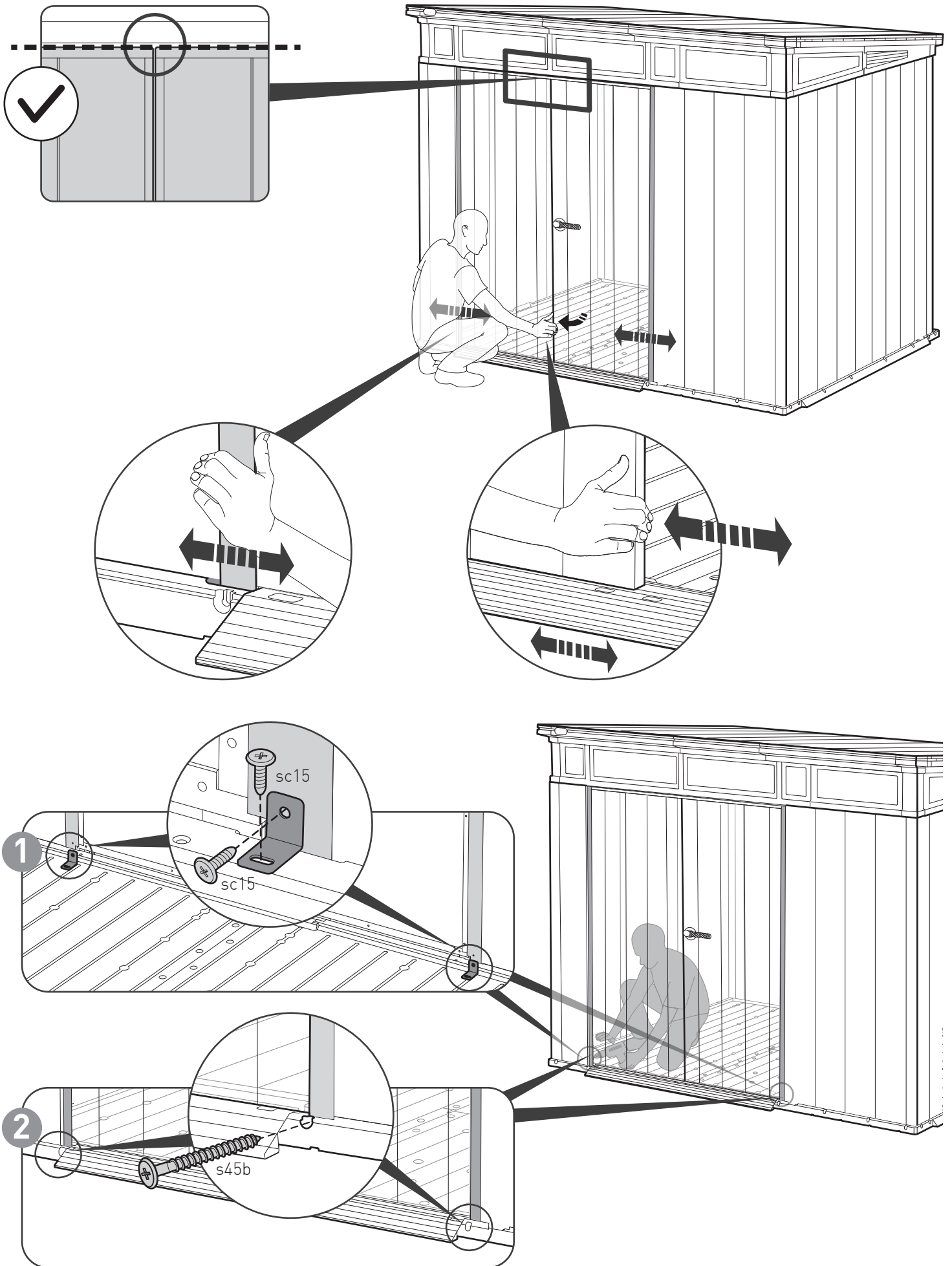



OPTION | 옵션

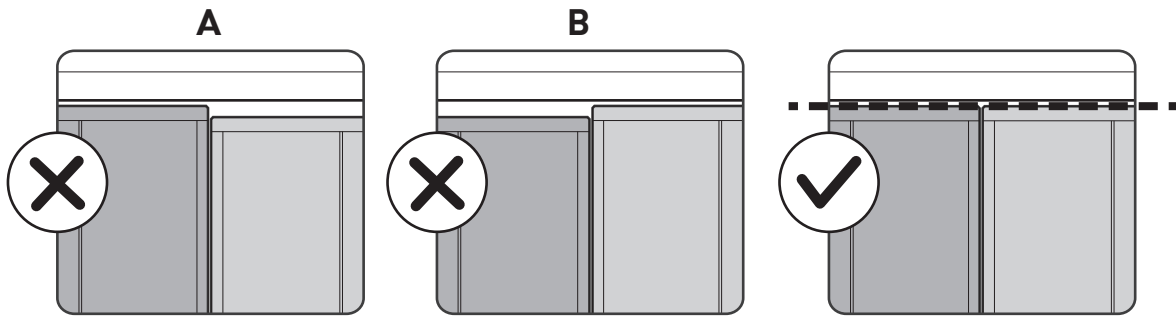
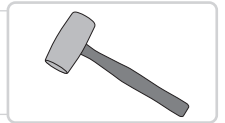

If you find that the shed is not level, use shims on either side of the shed or door | 설치장소 바닥 수평이 맞지 않아 문 높이가 맞지 않을 경우 별도의 썸을 사용하여 문 높이를 맞춰 주십시오.

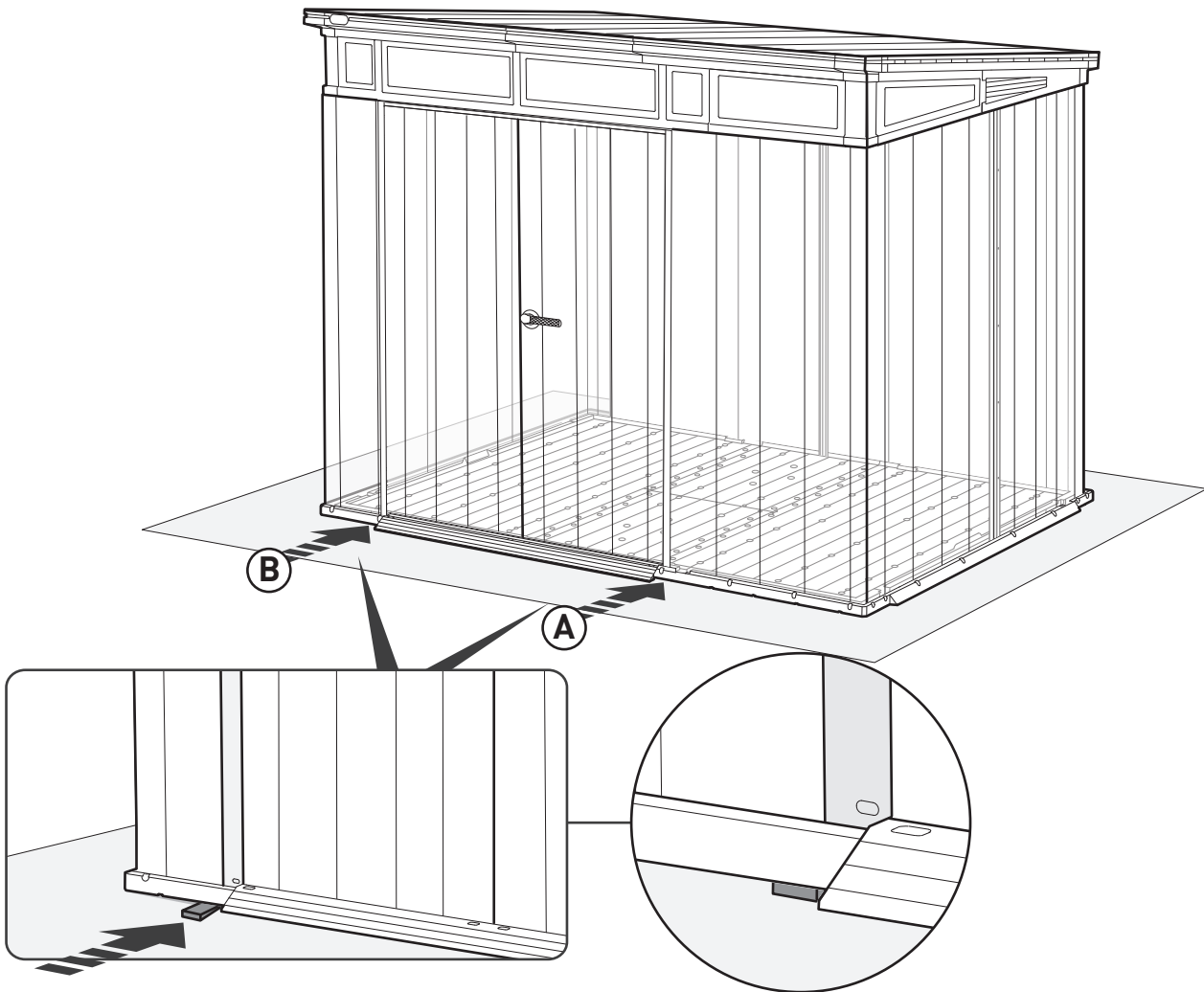

73

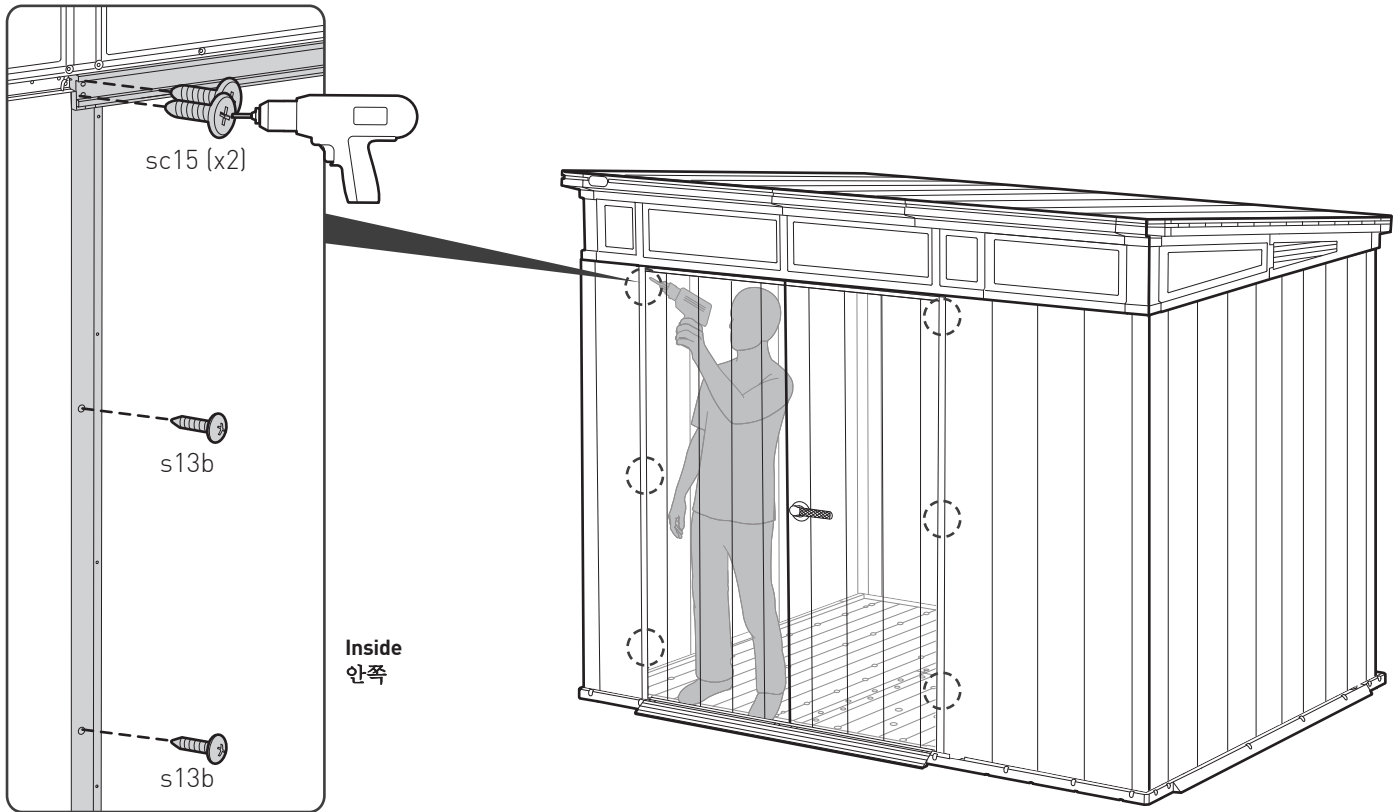

74

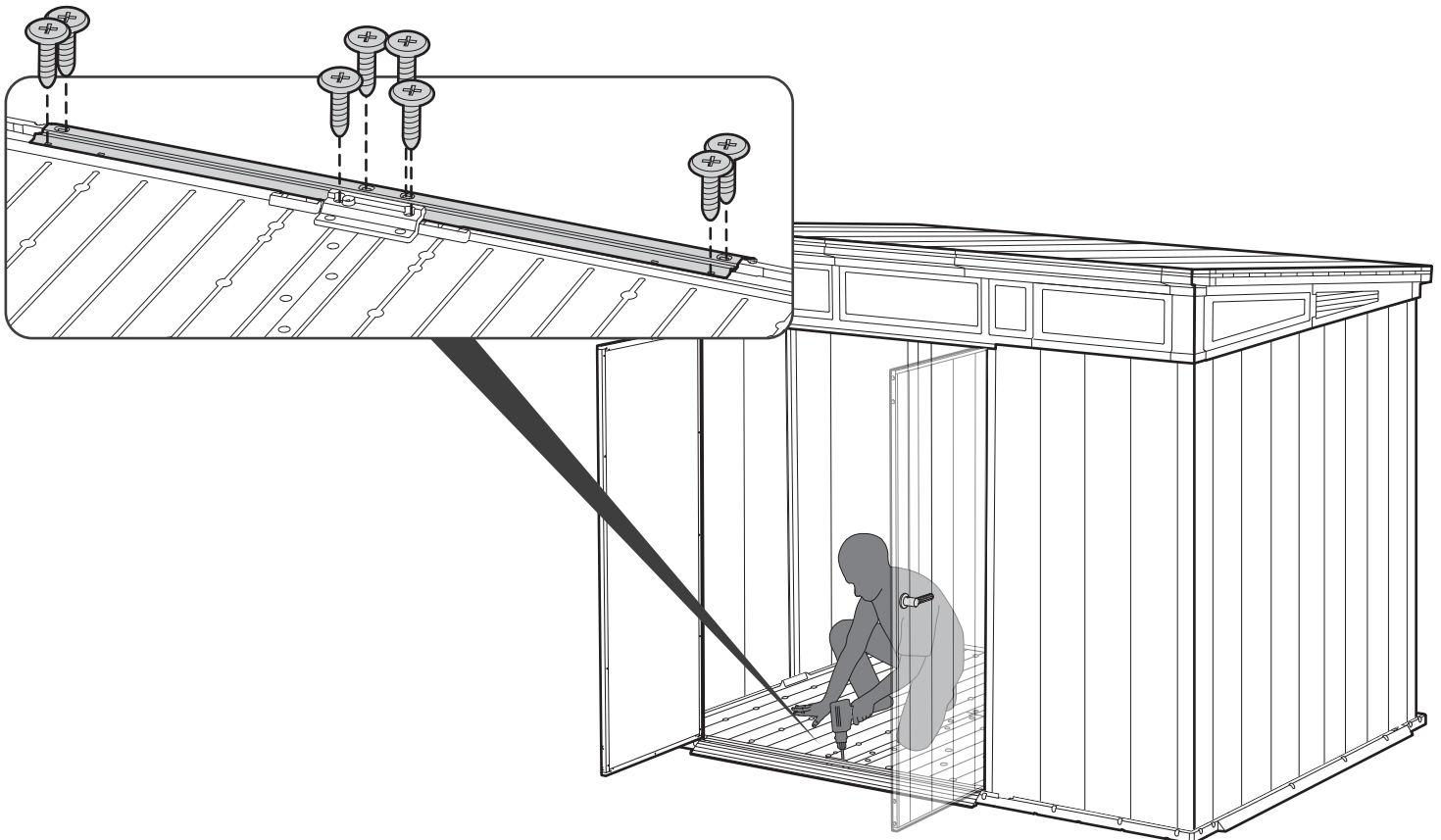



OPTION | 옵션

SECURING THE SHED TO A FOUNDATION

Affix the shed to the foundation by drilling holes in the shed floor at the pre-marked locations and screwing it into the foundation using appropriate screws (screws not included).

설치 장소 바닥에 창고 고정하기

창고 바닥에 표시된 곳에 구멍을 뚫어 나사나 앵커를 이용하여 설치 장소 바닥에 창고를 고정시킬 수 있습니다. (나사와 앵커는 포함되어 있지 않습니다)

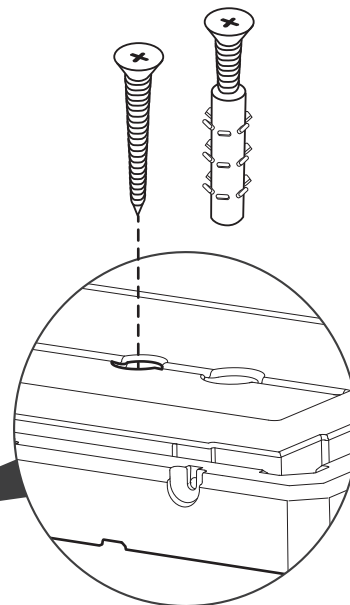
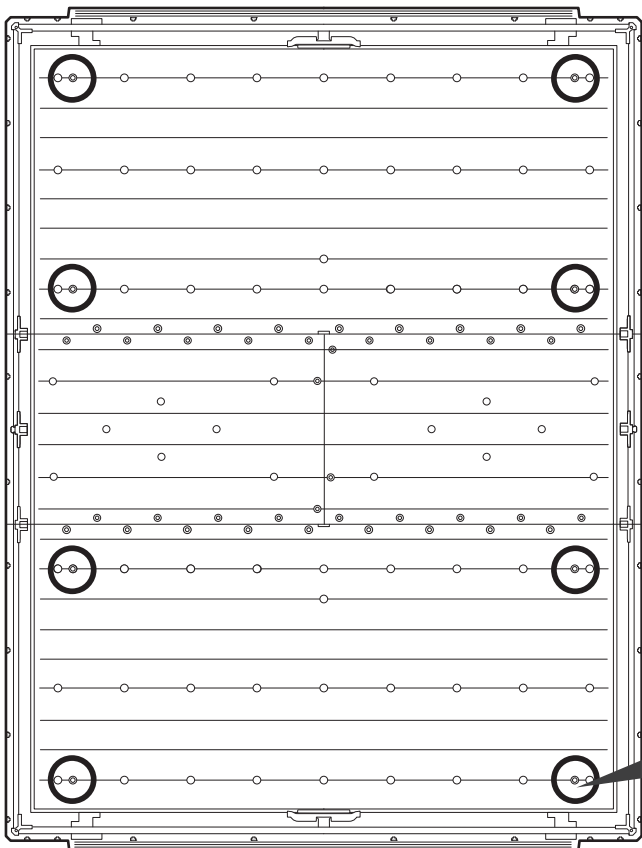
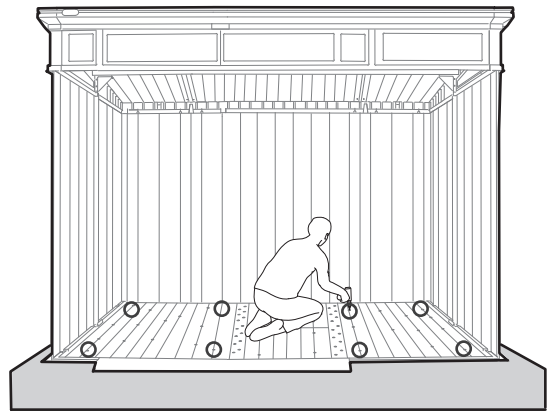



OPTION | 옵션

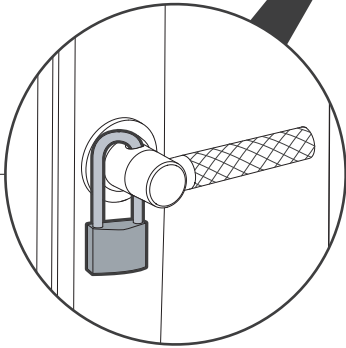
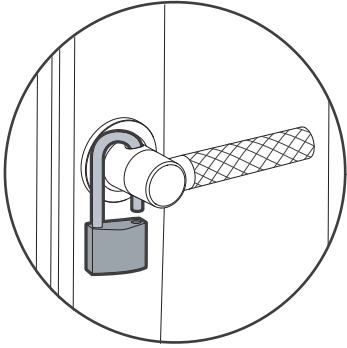
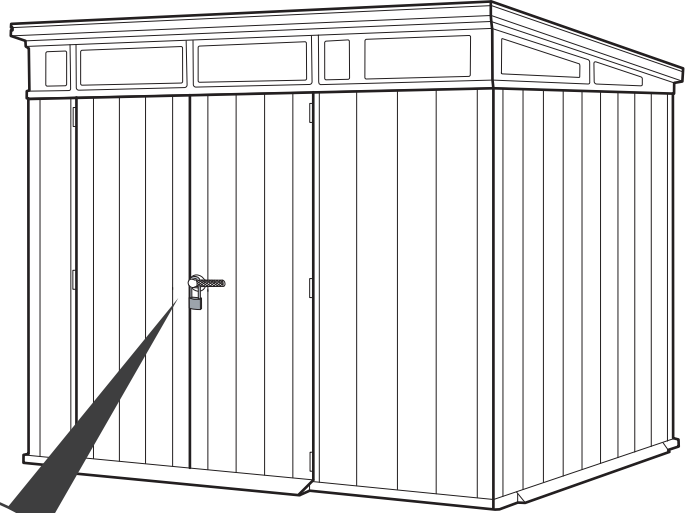
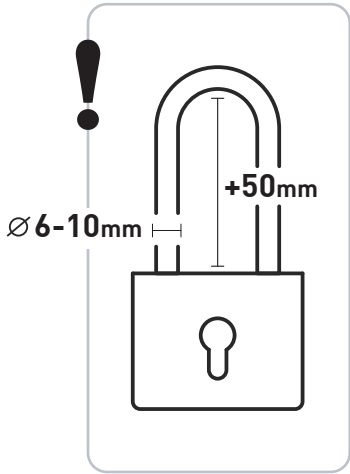
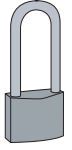

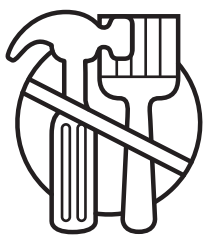

This shed is maintenance free. Paint or varnish are not necessary.
유지보수가 간편하며 별도의 페인트나 니스 작업이 필요 없습니다.



KETER DUOTECH™ SHEDS - UNIQUE PAINTABLE WALLS

This maintenance-free shed is made of a unique compound which enables the brushed wall-panels to be painted. The shed can be used in its original color, or the walls can be painted to match your landscape, deck, patio, or outdoor setting. Prior to painting, refer to the detailed care and maintenance instructions:

- Type of paint: The walls of the shed can be painted with a water-based acrylic paint for exterior use. Recommended: Solid, light shades, satin or semi-gloss finish. Consult with your color consultant or paint professional when choosing paint.
 - Application: Use a roller to apply the paint on the wall dry surface. Do not paint the beam-like crevices in the walls.
 - Do not paint windows, doors or door beam, roof, floor, or any other part of sheds.
- Keep in mind: Painting requires maintenance. After some time, repainting may be required.
For your safety - make sure you follow the paint's care & safety guide prior to application.

KETER DUOTECH™ SHEDS - 페인트칠이 가능한 특별한 벽

특별한 제작방식으로 페인트칠이 가능한 브러쉬드 창고입니다. 원래의 색으로 사용하거나, 창고의 벽을 주변 풍경, 정원, 또는 야외 환경에 맞게 페인트를 칠 할 수 있게 제작되었습니다. 페인트칠을 시작하기전에 다음 세부 관리 및 유지 방법 지침을 참조하십시오.

- 수성 아크릴 페인트를 이용하여 벽을 칠할 수 있습니다.
- (권장하는 페인트 종류: 솔리드, 라이트 새도, 새틴 또는 세미 글로스 마감.)
- 작업에 앞서 반드시 전문가와 페인트 타입, 색상과 작업 방식을 상의하십시오.
- 롤러를 이용하여 마른 브러쉬드 벽면에 페인트칠을 해주십시오.
- 바깥면에만 칠하시고 벽면에 틈이 있거나 갈라짐이 있을 경우 페인트칠을 하지마십시오.
- 창문, 문, 문기둥, 지붕, 바닥, 작은 부품에는 페인트칠을 하지 마십시오.
- 페인트칠은 시간이 지남에 따라 재작업이 필요할 수 있습니다.
- 안전을 위해 올바른 방법을 숙지하고 보호 장비를 갖추고 작업하십시오.

CARE AND SAFETY GUIDELINES

- The shed is intended for storage purposes only. It is not designed for habitation.
- It is strongly recommended to secure the shed to an immovable object or anchor to the ground by drilling holes in the shed floor (at the pre-marked locations) and inserting proper screws into the ground (screws are not included).
- Do not attempt assembly on windy or cold days.
- Periodically check the shed to ensure that it is stable and that the site is level.
- Be careful when handling parts with steel edges.
- When assembling or handling the shed, use only those tools listed in the user manual.
- Avoid using a lawnmower or mechanical scythe near the shed.
- Wear safety goggles and always follow the manufacturer's instructions when using power tools.
- Wash the shed with a garden hose or a mild detergent solution. Do not use a stiff brush or abrasive cleaners, including degreasers and oil- or acetone-based cleaning materials, as these may stain or damage the shed.
- Do not store hot items, such as recently used grills and blowtorches, and volatile chemicals in the shed.
- Avoid placing heavy items against the walls, as this may cause distortion.
- Keep the roof clear of accumulated snow and leaves. Large amounts of snow on the roof can damage the shed, making it unsafe to enter.
- Wind direction is an important factor to consider when determining the location of the shed. Reduce exposure to the wind, in general, and of the door side in particular. Keep doors closed and locked when the shed is not in use to prevent wind damage.
- Do not stand on the roof.
- Consult your local authorities to check if permits are required to erect the shed.

조립, 관리 및 안전에 관한 주의사항

- 창고는 반드시 물건 보관용으로 사용하시고 주거용으로 사용하지 마십시오.
- 창고를 움직이지 않는 물체에 고정시키거나 (창고 바닥에 표시되어 있는 부분을 뚫어)나사를 이용해 땅에 박아 고정할 것을 권장합니다. (나사는 포함되어 있지 않습니다.)
- 바람이 불거나 비가 오는 날, 추운 날에는 조립하지 마십시오,
- 주기적으로 창고의 조립 상태나 설치 장소의 지면 상태를 확인해주시시오.
- 부품의 모서리가 날카로우니 주의를 기울여 작업하십시오.
- 창고를 조립할 때에는 조립설명서에 나온 도구를 사용하십시오.
- 안전을 위해 항상 장갑, 고글, 긴소매 옷을 착용하십시오.
- 창고 주변에서 잔디깎기나 낫을 사용할 경우 주의하십시오.
- 청소할 때에는 물이나 연한 세제를 사용하고 뾰뾰한 솔, 연마용 도구, 기름 종류의 재료는 사용하지 마십시오.
- 방금 사용한 그릴, 토치 같은 뜨거운 물건이나 휘발성 제품은 창고에 보관하지 마십시오.
- 무거운 물건을 창고 벽에 기대어 놓으면 창고가 손상될 수 있습니다.
- 사람이 다치거나 창고가 손상될 수 있으니 지붕에 쌓인 눈이나 낙엽들은 바로바로 치워주십시오.
- 창고 위치는 바람의 영향을 최대한 받지 않는 곳으로 결정하시고 항상 문단속을 철저히 하고 자물쇠도 설치해주시시오.
- 지붕에 올라가지 마시고 물건도 올려놓지 마십시오.
- 창고 설치 전에 반드시 해당 공공기관으로 문의하시고 별도의 삽지를 참고해 주십시오. 더 궁금한 사항이 있는 분들은 고객센터로 연락하십시오.
- 지상에 설치할 경우 해당 공공기관에 신고를 해야합니다 .
- 농막의 경우도 농지 전용 절차 없이 설치 가능하나 농업 경영에 이용하는 토지에 설치하는 시설일 것,
- 주거 목적이 아닌 농기자재 및 농약 등의 보관, 작업 중 휴식 및 간이 취사 시설일 것,
- 전기/수도/가스 등 간선 공급 시설을 요하지 않을 것 등의 요건을 갖추어야 하며 역시 신고를 해야 합니다.
- 옥상의 경우 어떠한 가설 건축물이든지 반드시 허가를 받아야 합니다 .
- 제품의 재질이 합성수지이므로 허가 가능 재질인지 설치 전 꼭 해당 공공기관에 문의하시기 바랍니다 .
- 각 지역의 특성상 유권 해석이 상이하기 때문에 법적으로 더 자세한 내용을 알고 싶으시면
- 설치전에 반드시 해당 공공기관으로 문의하여 문제가 발생하지 않도록 하시기 바랍니다.



LIMITED LIFETIME WARRANTY

Your Keter shed (“the Product”) was manufactured from high-quality, recyclable materials under rigorous control and supervision.

Should a problem occur with the Product, please address your claim to Keter customer service on our website (www.keter.com) or by phone.

This warranty covers product failure resulting from defects in manufacturing or materials for an unlimited period from the date of original retail purchase. (The term “defects” is defined as imperfections that impair the use of the Product).

This warranty does not cover defects resulting from normal wear and tear, including, but not limited to, scuffing, scratches or fractures caused during use, discoloration or fading, rusting, unreasonable use, abuse, negligence, alterations, painting, moving, transporting or relocating the Product, “acts of Nature,” including, but not limited to, hail, any type of storm, flood and fire, and consequential or incidental damages.

Assembly and handling not in accordance with the recommendations, guidelines and restrictions as described in the Product’s user manual, and usage for commercial or public applications, will void this warranty.

Keter is not responsible for any damage incurred by consumer and/or third parties or damage to or loss of objects inside or near the shed.

품질 보증 설명

KETER의 조립식 창고는 엄격한 관리 아래 고품질의 재료와 재활용이 가능한 재료로 제작하고 있습니다.

제품에 문제가 발생한 경우 웹사이트 고객센터에 접속하거나 연락하여 클레임을 해결하십시오.

제품에 결함이 있을 경우 구매일로부터 10년 동안 품질보증이 적용됩니다. (결함은 제품 기능이 저하되는 것을 의미합니다).

사용 중에 발생한 마모, 찢김, 구멍, 흠집, 균열, 변색, 색 바램, 녹, 오남용, 과실, 개조, 도장, 이동, 제품의 운반 및 재 조립을 포함한 우박, 태풍, 강풍,

홍수, 화재, 대설 등의 자연 재해로 인한 문제에 대해서는 품질보증을 하지 않습니다.

조립 설명서대로 조립하지 않았거나 주의사항 무시, 상업적 용도 혹은 공적인 용도로 사용 할 경우에도 품질보증을 하지 않습니다.

제 3자에 의한 피해나 창고 내 외부에 있는 물건의 분실에 대해서도 KETER는 책임지지 않습니다.





**IF THERE ARE MISSING OR BROKEN PARTS, PLEASE DO NOT RETURN THE PRODUCT TO THE STORE.
Please log onto our website, or contact Customer Service at:**

조립시에 궁금한 점이나 부품에 문제가 있어 교환이 필요하신 분들은 고객센터로 연락주시기 바랍니다.

고객 센터
TEL.031-767-2492
FAX.031-767-2492
E-mail.info@keter.co.kr

WWW.KETER.COM



NOUS SOUCIONS | NOS IMPORTA

A better world with Keter.

From material innovation to manufacturing processes we encourage sustainable consumption.

Made in Israel by |

Keter Plastic Ltd., 1 Sapir St. Industrial Area, Herzliya 46852, Israel

