



STORE-IT-OUT MAX

USER MANUAL | 조립 설명서

IMPORTANT 중요

RETAIN FOR FUTURE REFERENCE: READ CAREFULLY 조립 설명서를 보관하시고 주의 깊게 읽어주세요.

For outdoor use only. Not for commercial use 실외용. 상업적 용도가 아님.

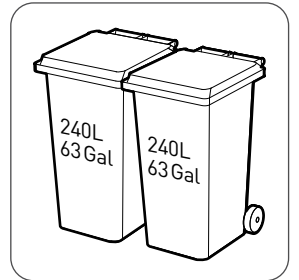
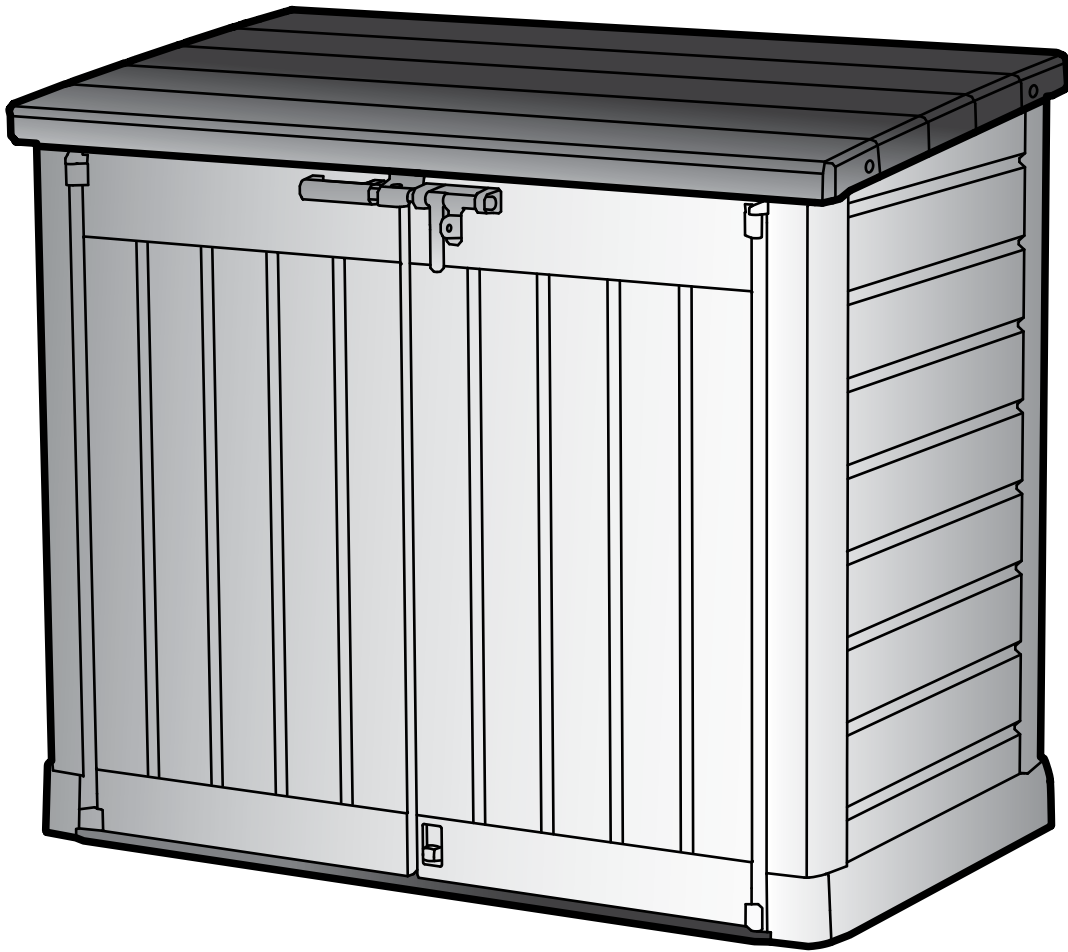

A-1404 581054

SKU: 17199416 | 17199418

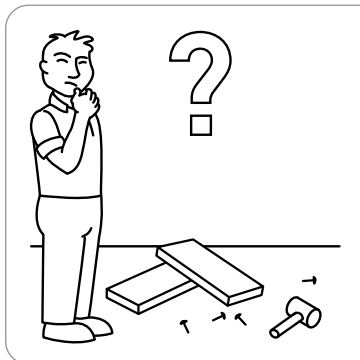

고객 센터
TEL.031-767-2492
FAX.031-717-2497
E-mail.info@keter.co.kr
월 - 금 10:00am - 5:30pm

WWW.KETER.COM

WARRANTY ACTIVATION

Thank you for your purchase of the Keter shed. In order to activate your warranty, please log onto our website and fill in the form under warranty activation.

보증 활성화 | 케터 창고를 구입해 주셔서 감사합니다. 보증을 활성화하려면 당사 웹 사이트에 로그인하여 보증 활성화 양식을 작성하십시오.

LEVEL THE GROUND SURFACE | 땅 고르기

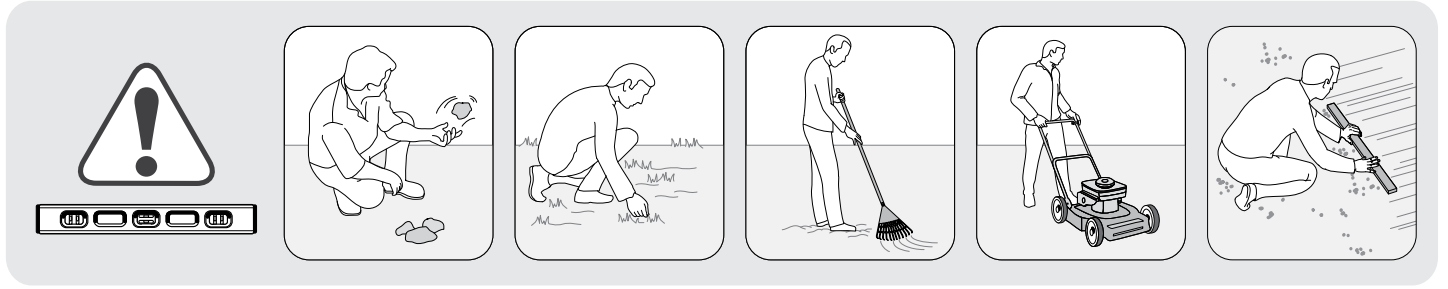

REQUIRED TOOLS | 필요한 도구

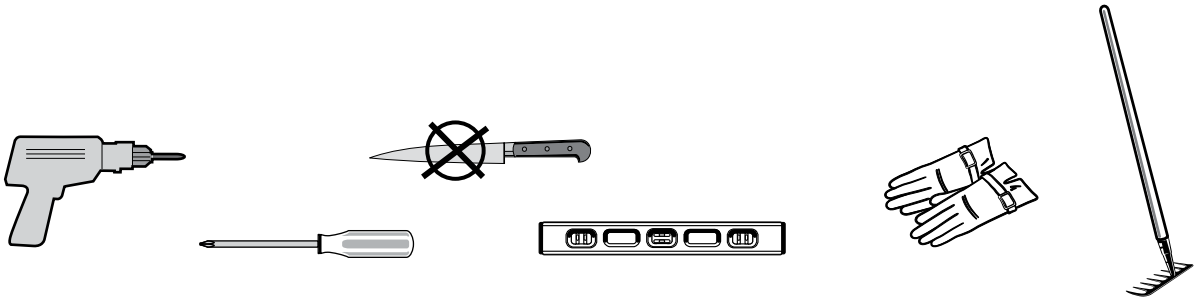







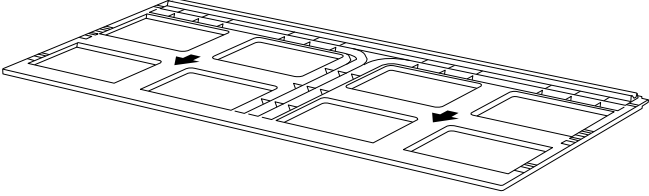
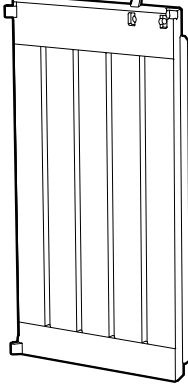
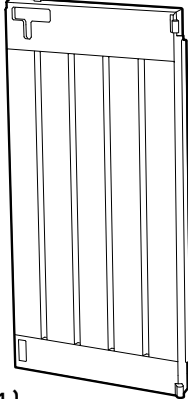
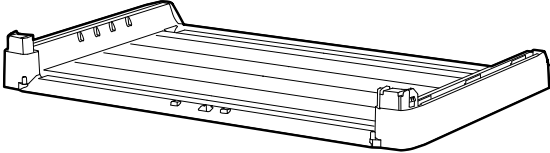
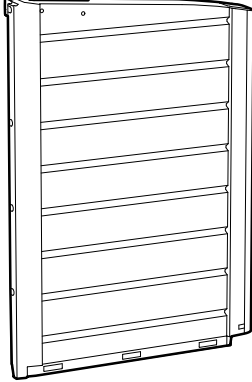
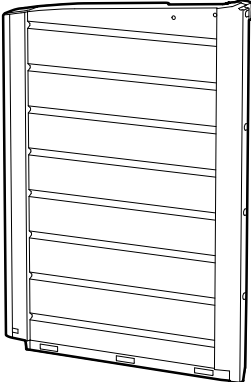
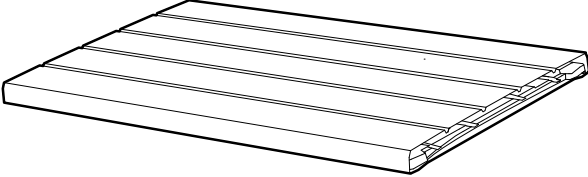
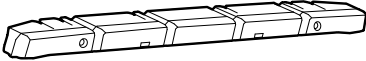

BEFORE STARTING ASSEMBLY | 조립을 시작하기 전에 확인할 내용

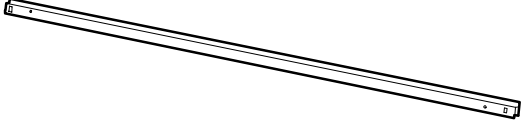
Read the care and safety guidelines at the end of this manual | Check to ensure that there are no missing or damaged parts BEFORE starting or arranging assembly | Remove all parts from the package(s) and spread them out on a clean work surface | Review all assembly instructions | Assemble all the parts according to the directions in this manual. Do not skip any steps.

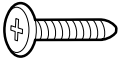
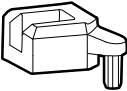
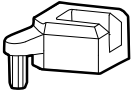
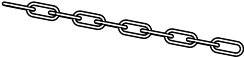
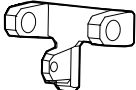
뒤쪽에 있는 조립, 관리 및 안전에 관한 주의사항을 읽어주십시오 | 시작하기 전에 누락되거나 손상된 부품이 없는지 확인하십시오 | 모든 부품을 포장지에서 제거하고 깨끗한 작업 표면에 펼쳐 놓으십시오 | 조립 설명서 전체 내용을 확인해보십시오 | 반드시 조립 설명서대로 조립하시고 어떤 단계도 건너뛰지 마십시오.

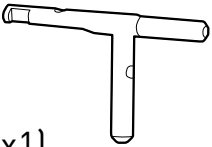
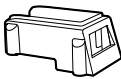
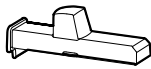
Code letters are imprinted on each part for easy identification | 부품 번호는 각 부품에 표시되어 있습니다.

 <p>WLPM (x2)</p>	 <p>WLDL (x1)</p>	 <p>WLDR (x1)</p>	
 <p>WLF (x1)</p>	 <p>WLDA (x1)</p>	 <p>WLDB (x1)</p>	
 <p>WLR (x1)</p>	 <p>WLAC (x2)</p>	 <p>WLPS (x2)</p>	 <p>WLBM (x1)</p>
 <p>WLCC (x2) WLCO (x2)</p>	 <p>s26b (x46)</p>	 <p>WLHL (x1)</p>	 <p>WLHR (x1)</p>
 <p>WLCN (x2)</p>	 <p>WLBP (x1)</p>	 <p>WLGN (x1)</p>	 <p>WLHD (x1)</p>
<p>WLCN (x2)</p>	 <p>WLBL (x1)</p>	 <p>WLBS (x1)</p>	 <p>WLDC (x1)</p>

Packaging may contain some additional small parts for use as spare parts | 예비 부품이 포함되어 있을 수 있습니다.

NOTE: Due to variations in production, the actual assembled size may vary slightly from the specified dimensions.

참고: 제작 특성상 명시된 사이즈와 실제 사이즈는 조금 다를 수 있습니다.



ASSEMBLY REQUIRES TWO PEOPLE | 2명 이상의 성인이 조립하시길 바랍니다.

1



WLF (x1)



WLDA (x1)



WLDB (x1)

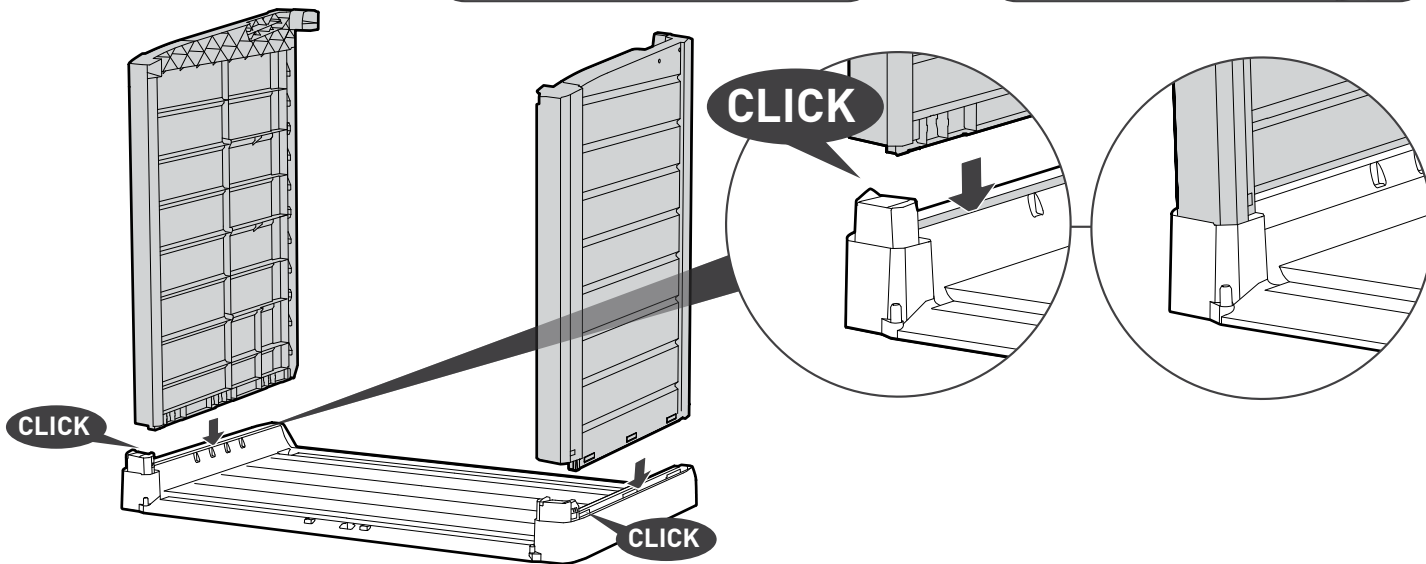
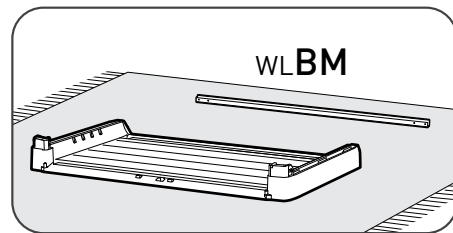
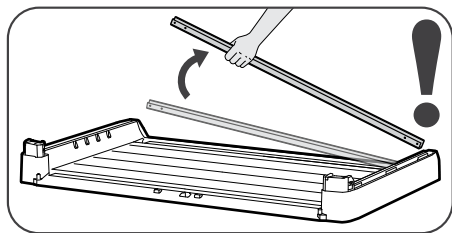

2

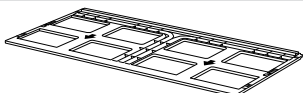

WLPM (x2)

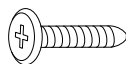

s26b (x5)

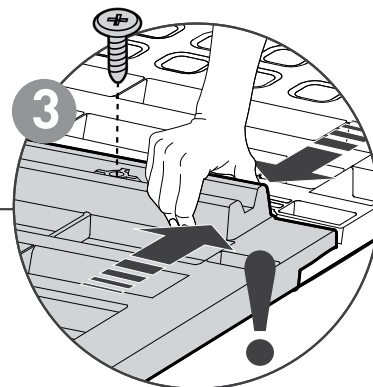
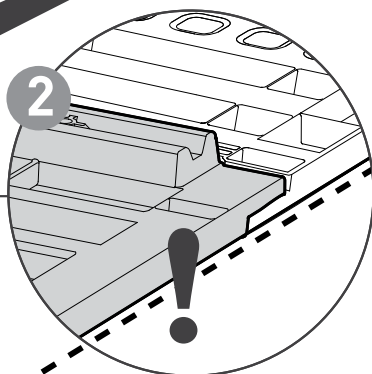
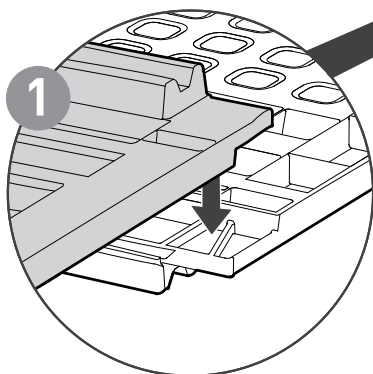
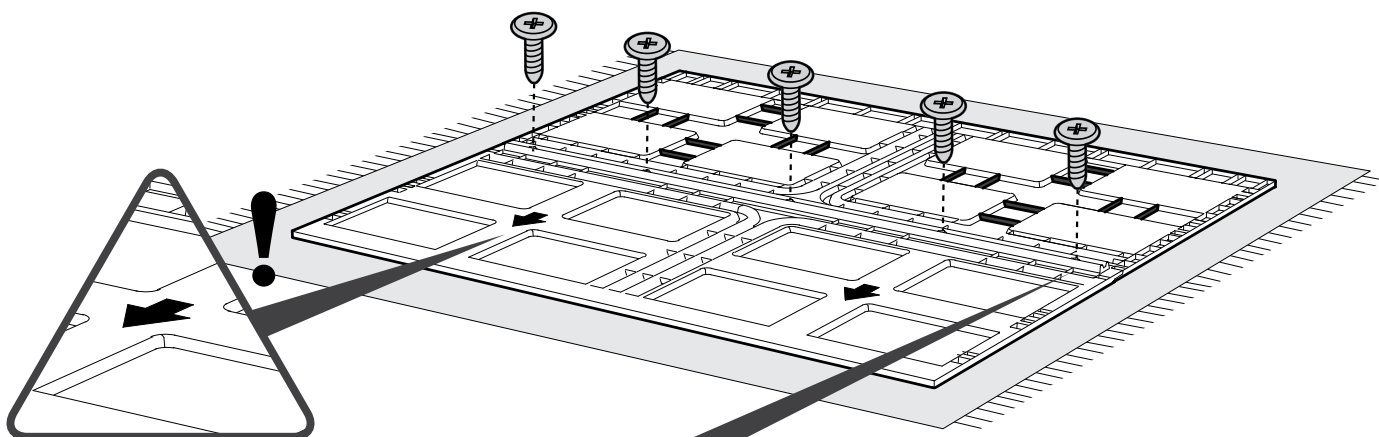

3

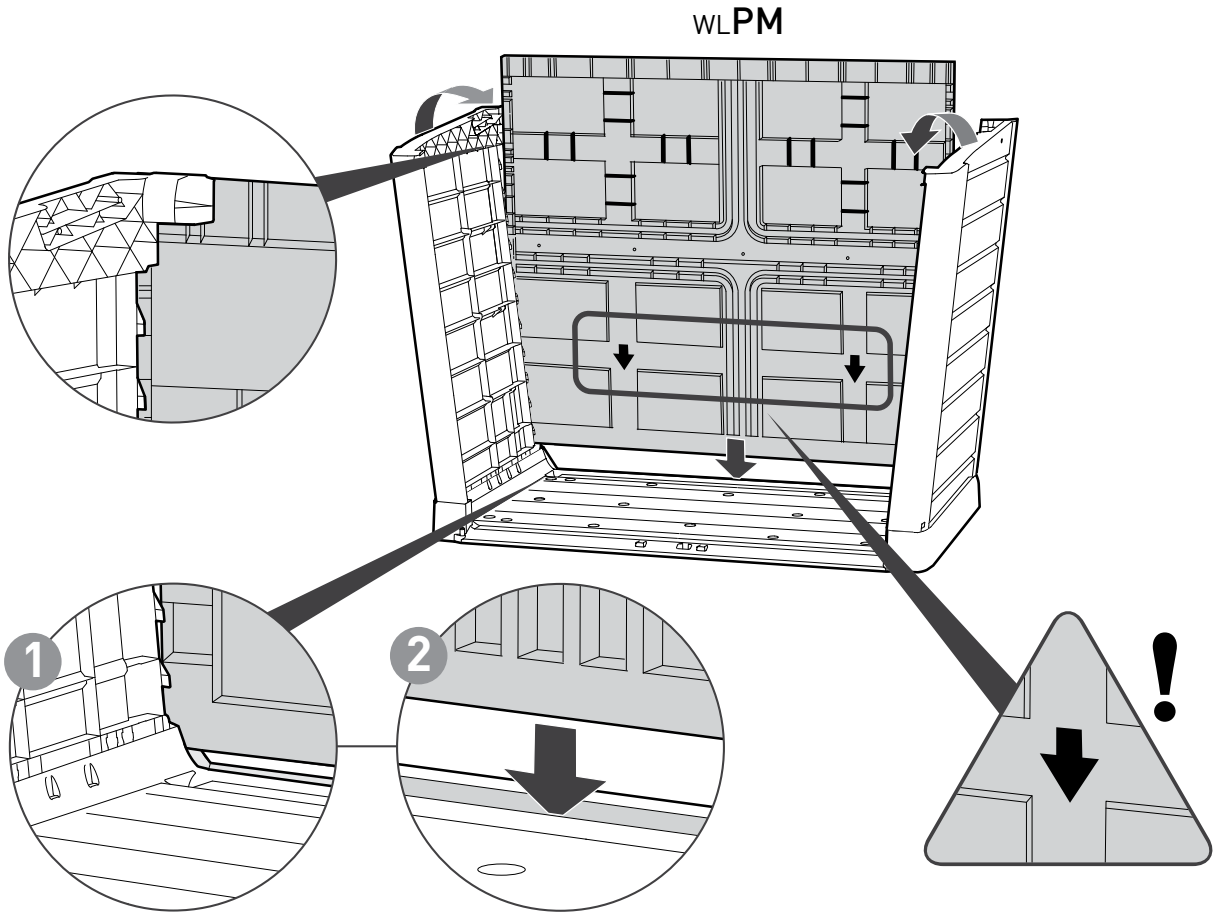

4



wLBM (x1)

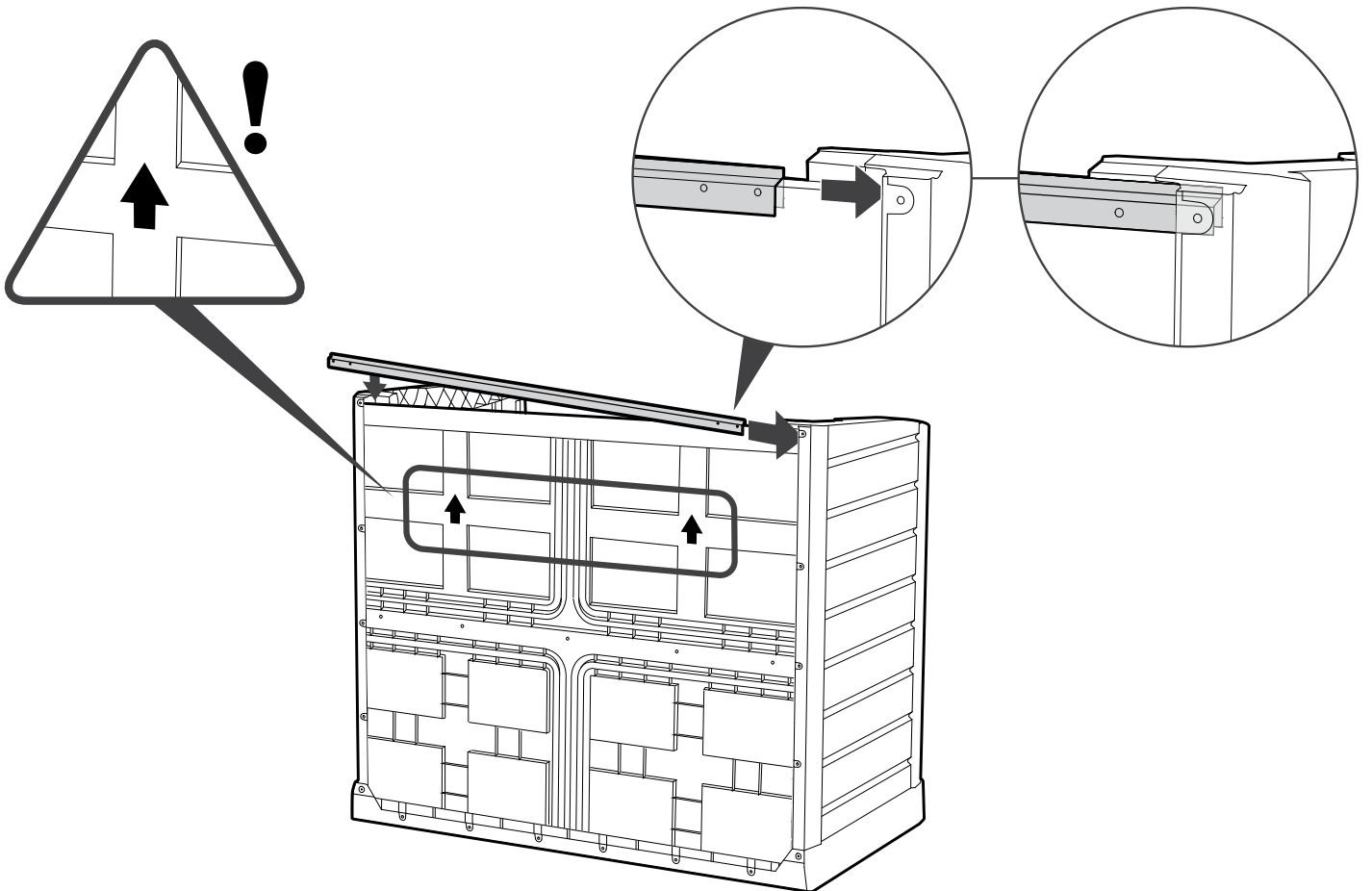

5

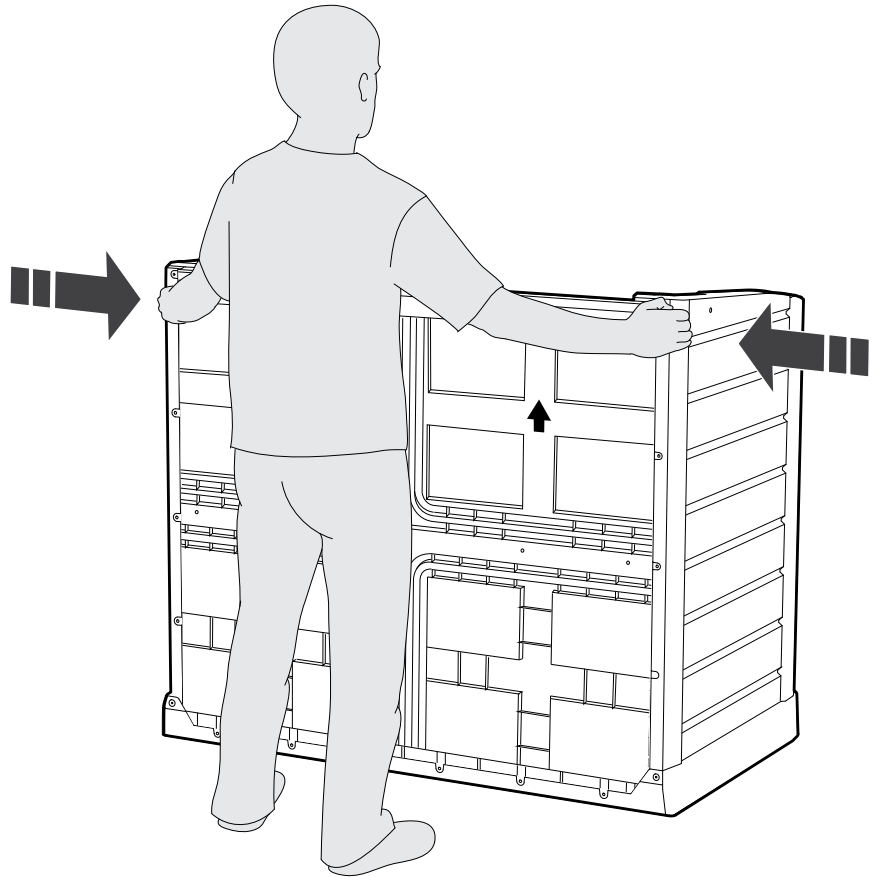

6

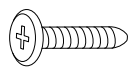

s26b (x18)

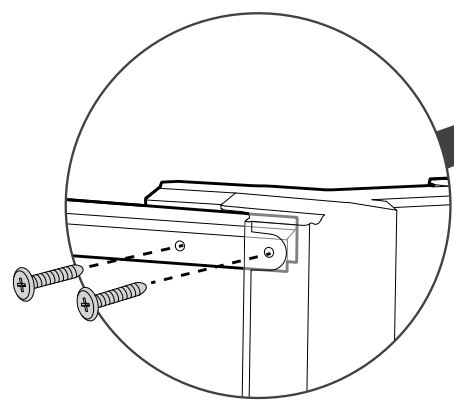
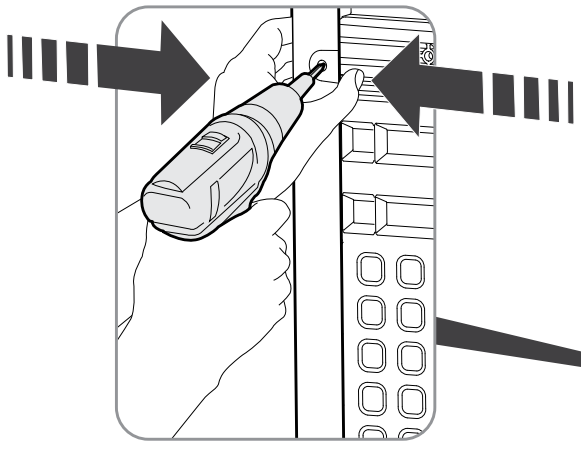

s26b (x18)

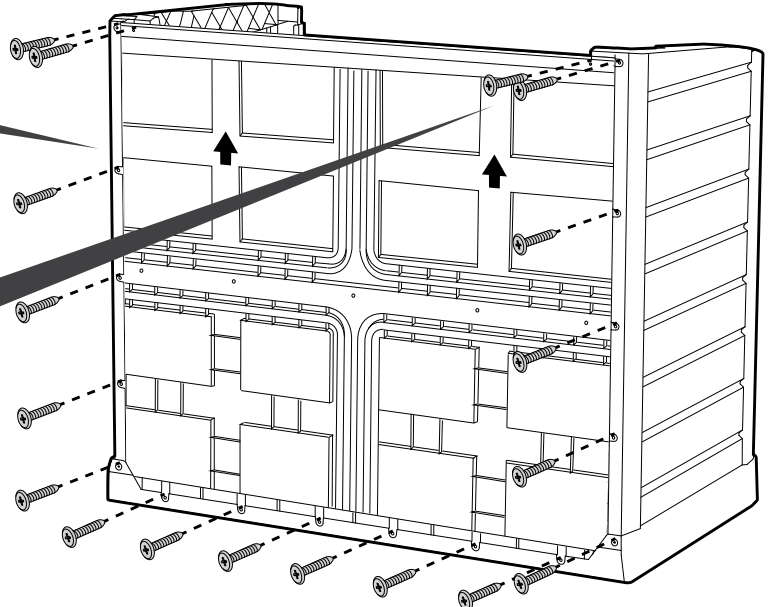

7



WLR (x1)

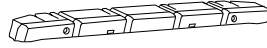

WLAC (x2)

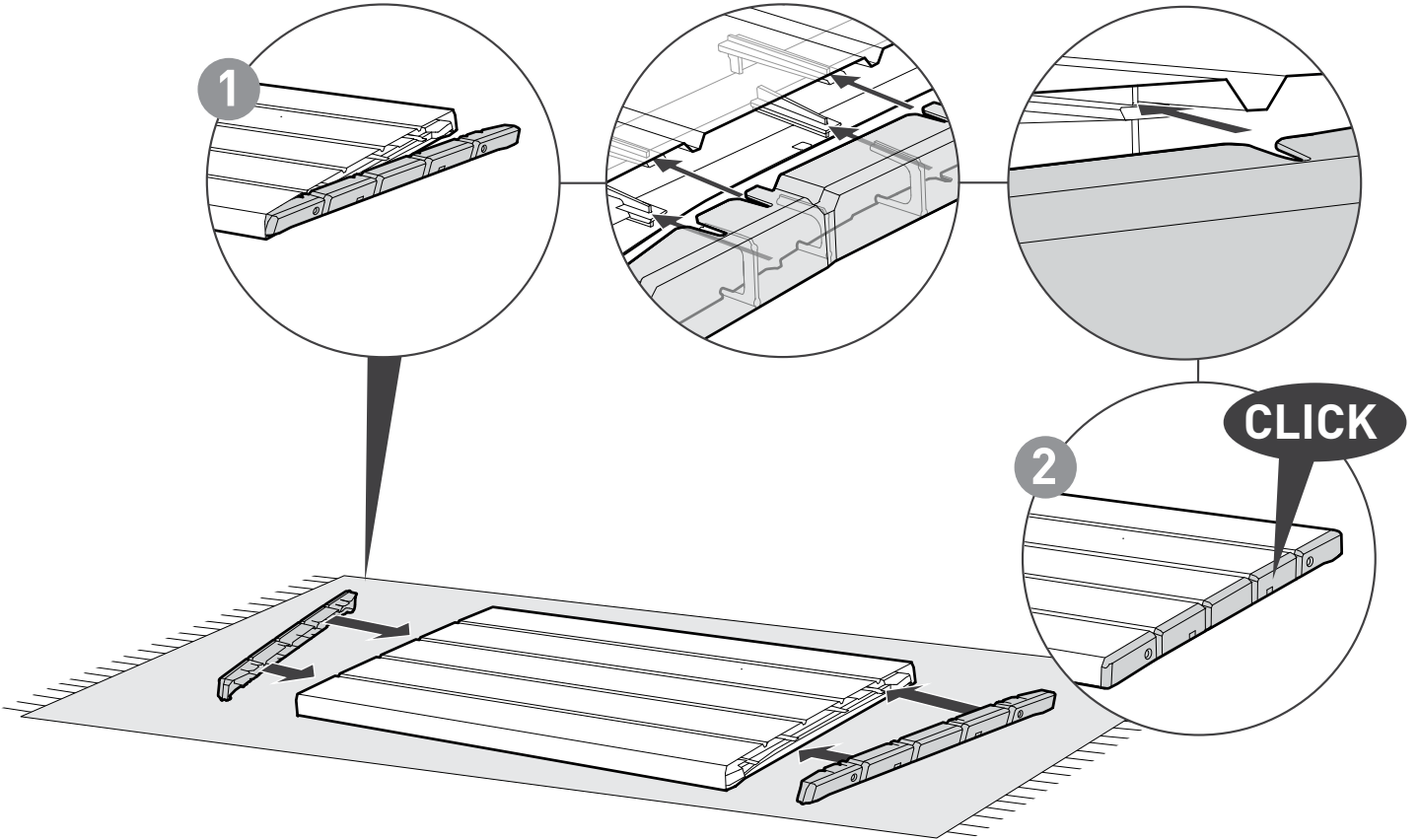

8

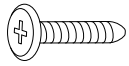

s26b (x4)

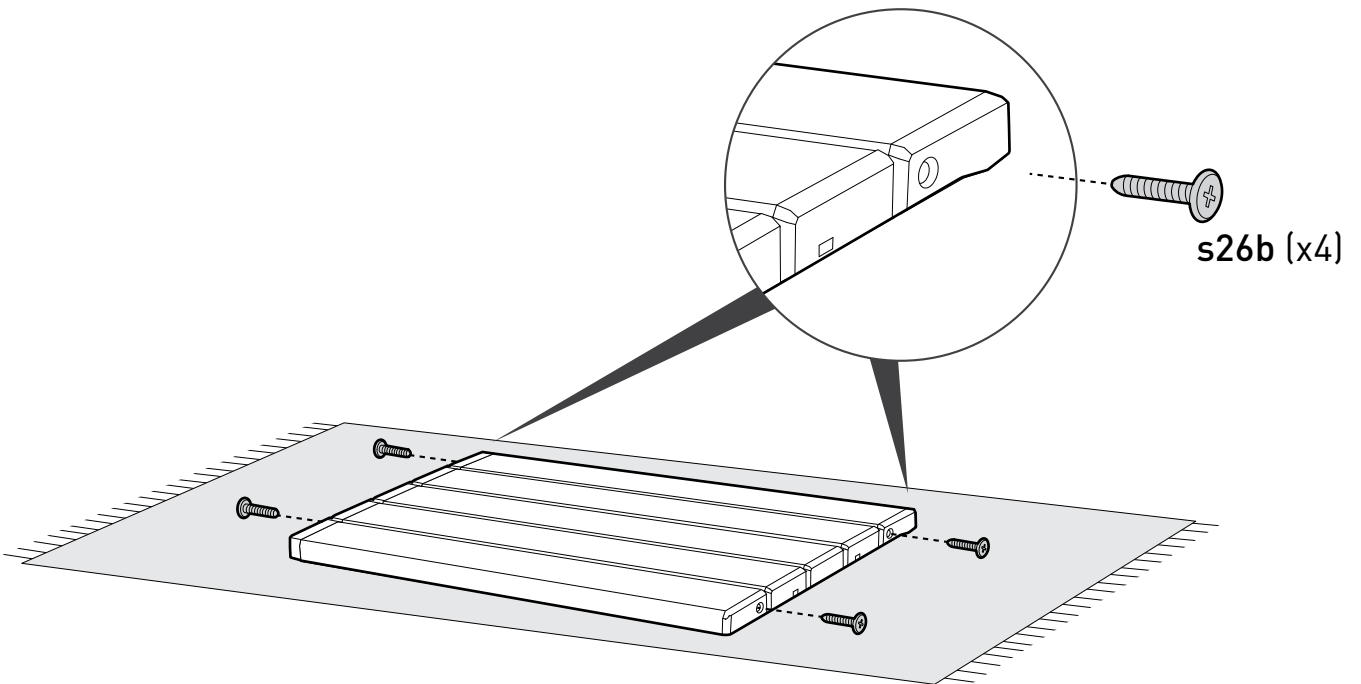

9



WLPS (x2)

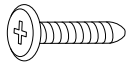

s26b (x4)

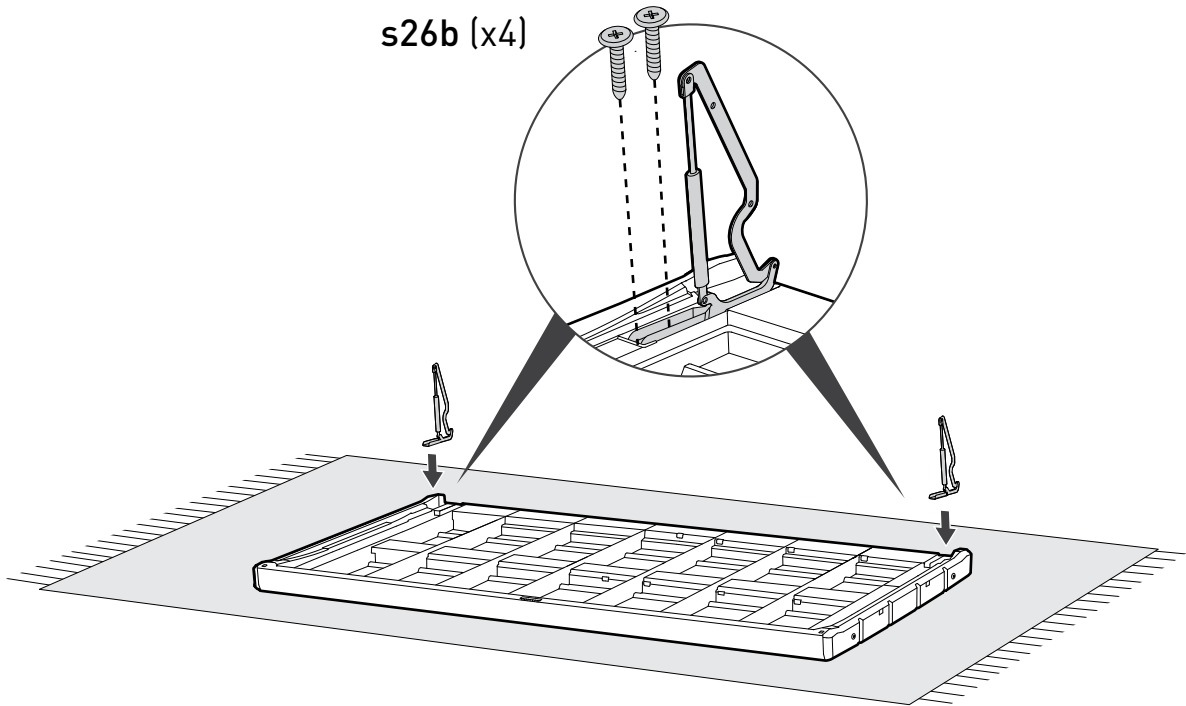

10



WLDC (x1)

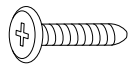

s26b (x2)

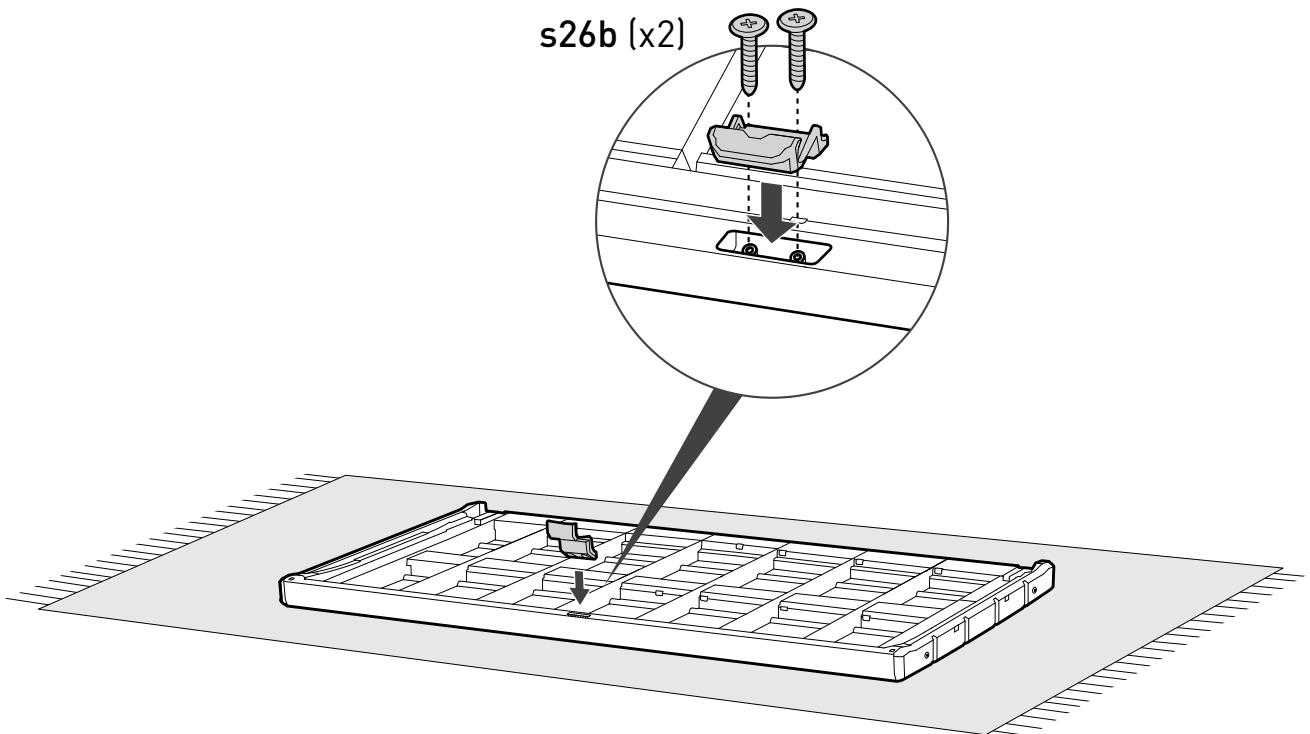

11

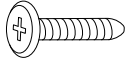

s26b (x4)

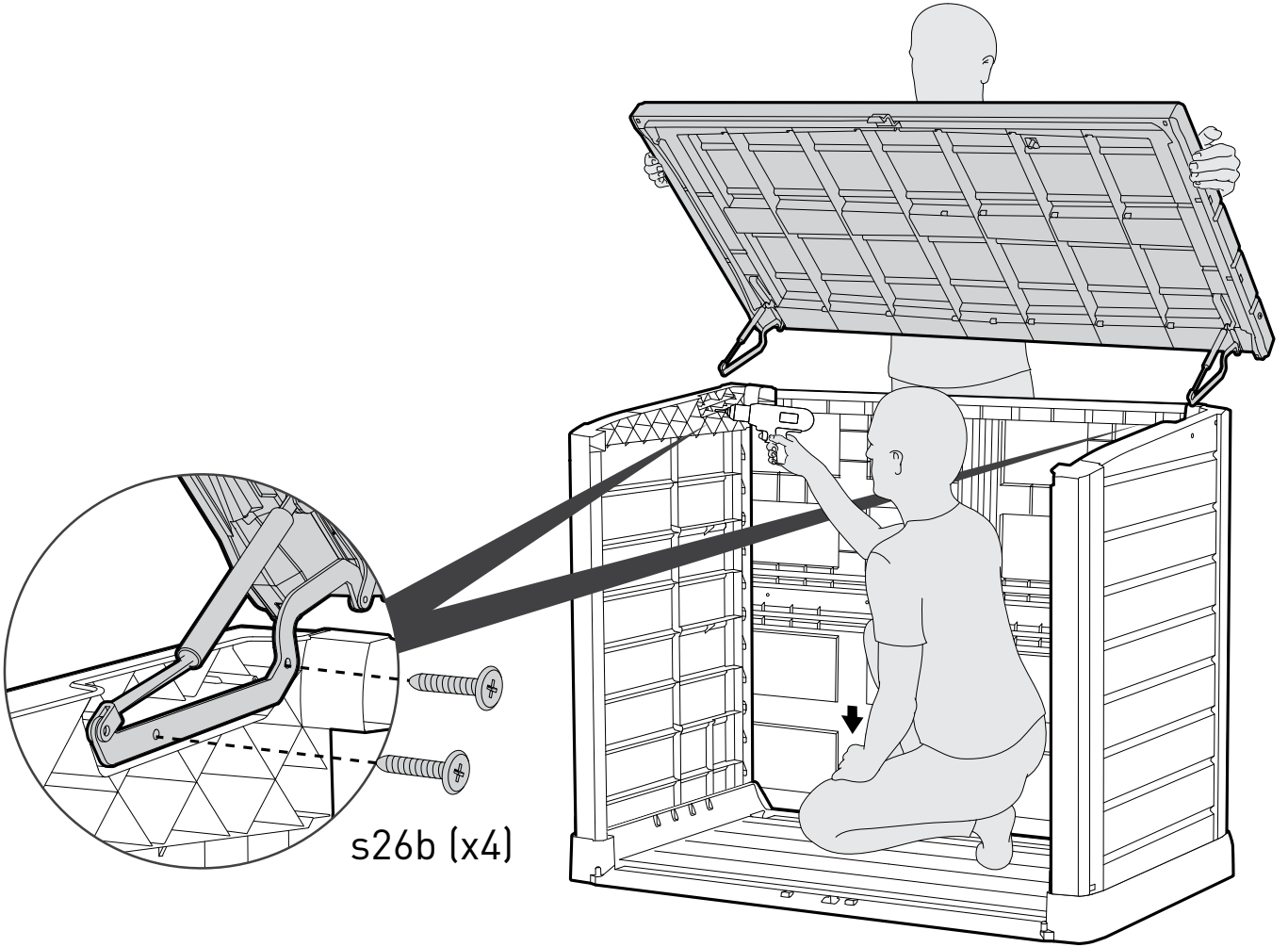

12



WLDR (x1)

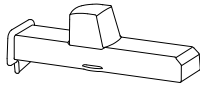

WLBS (x1)

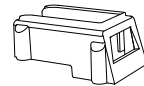

WLBL (x1)

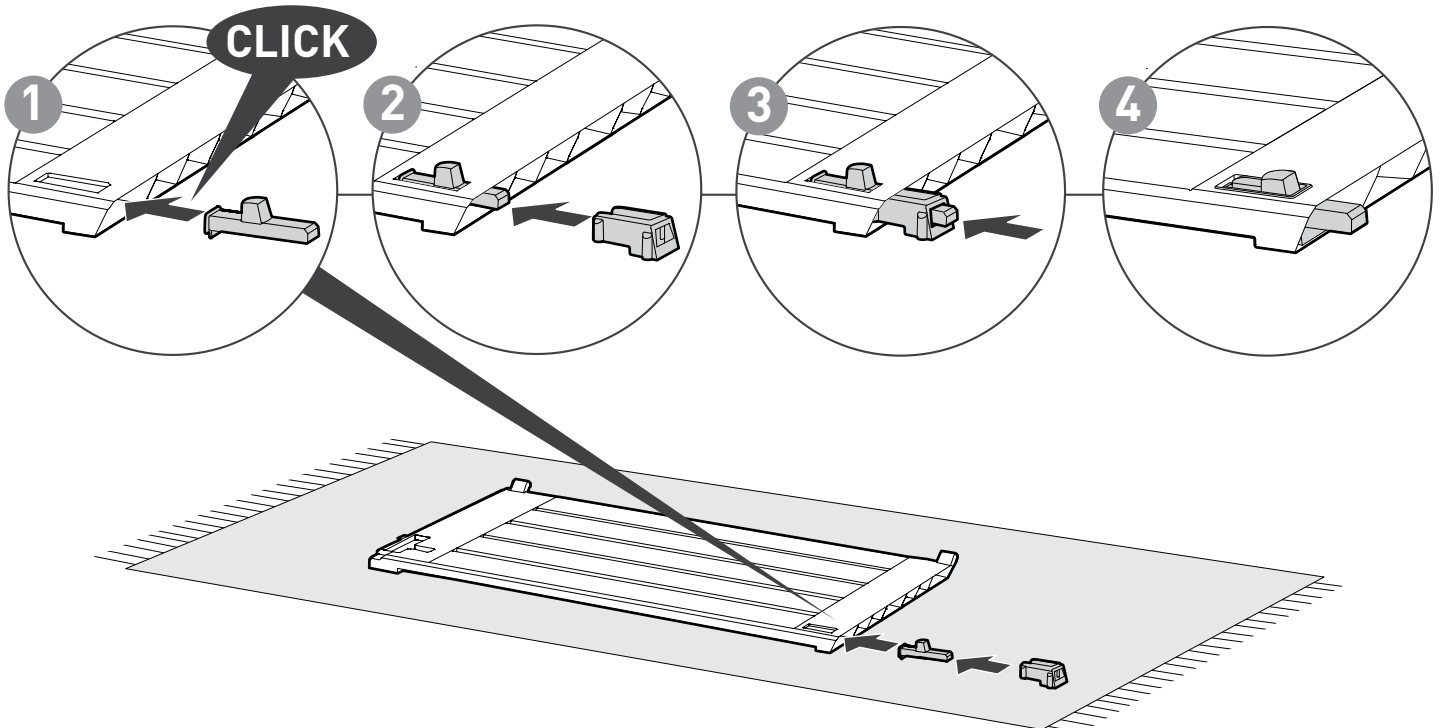

13

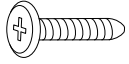

s26b (x3)

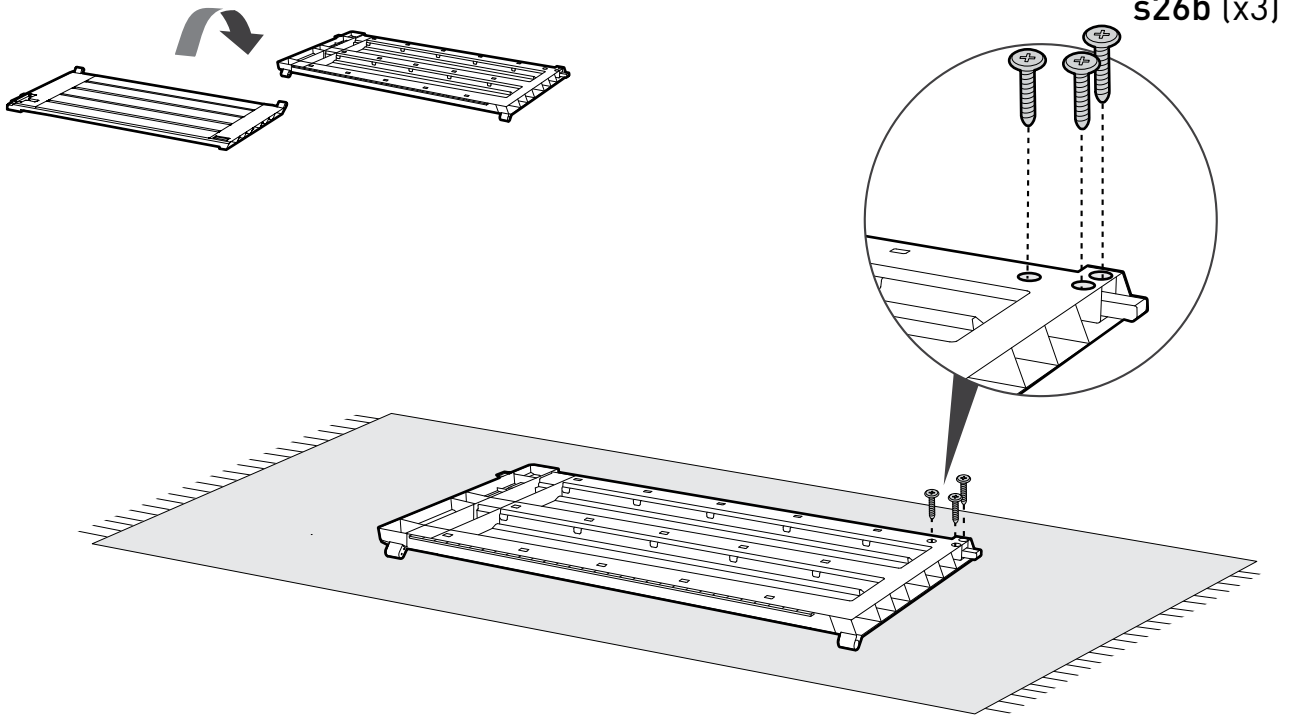

14

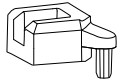

WLHL (x1)

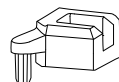

WLHR (x1)

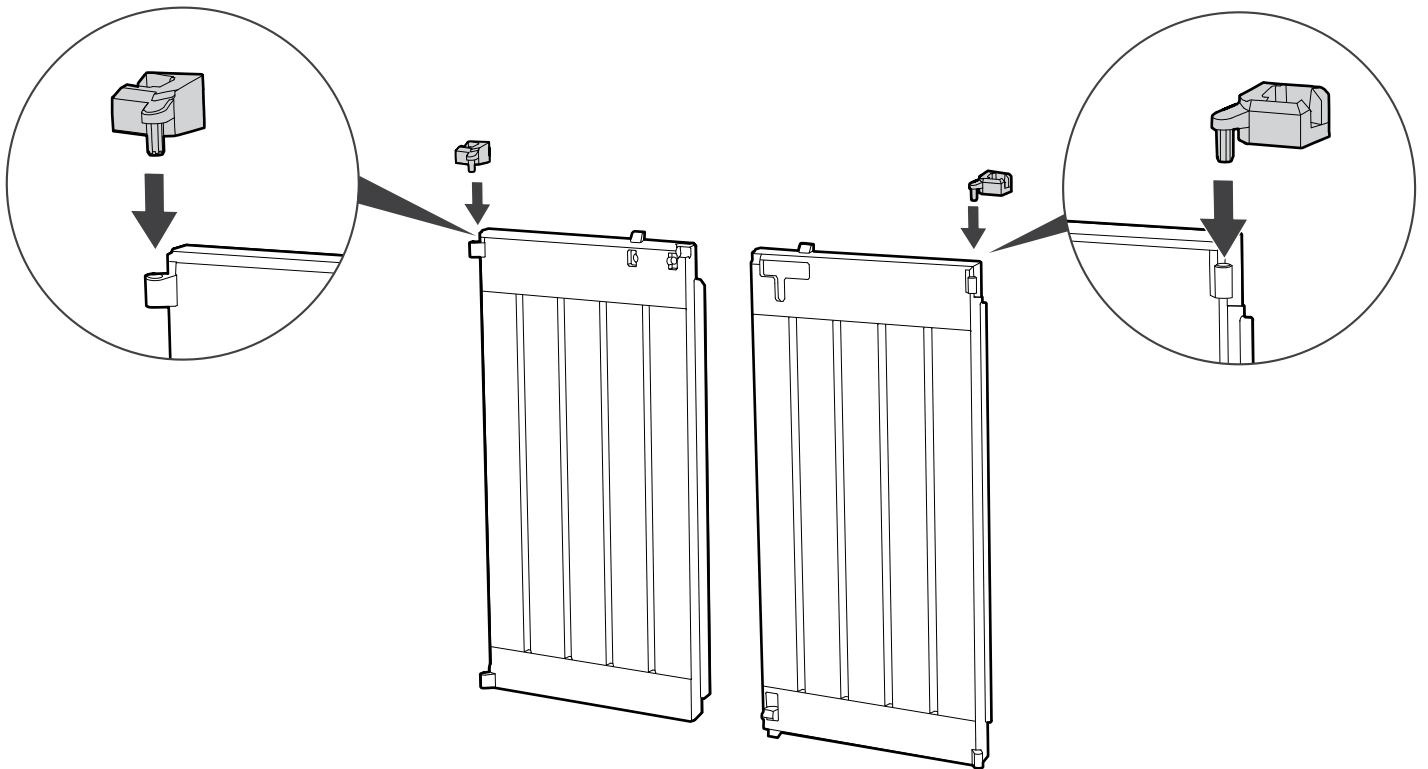

15



wLDL (x1)



wLDR (x1)

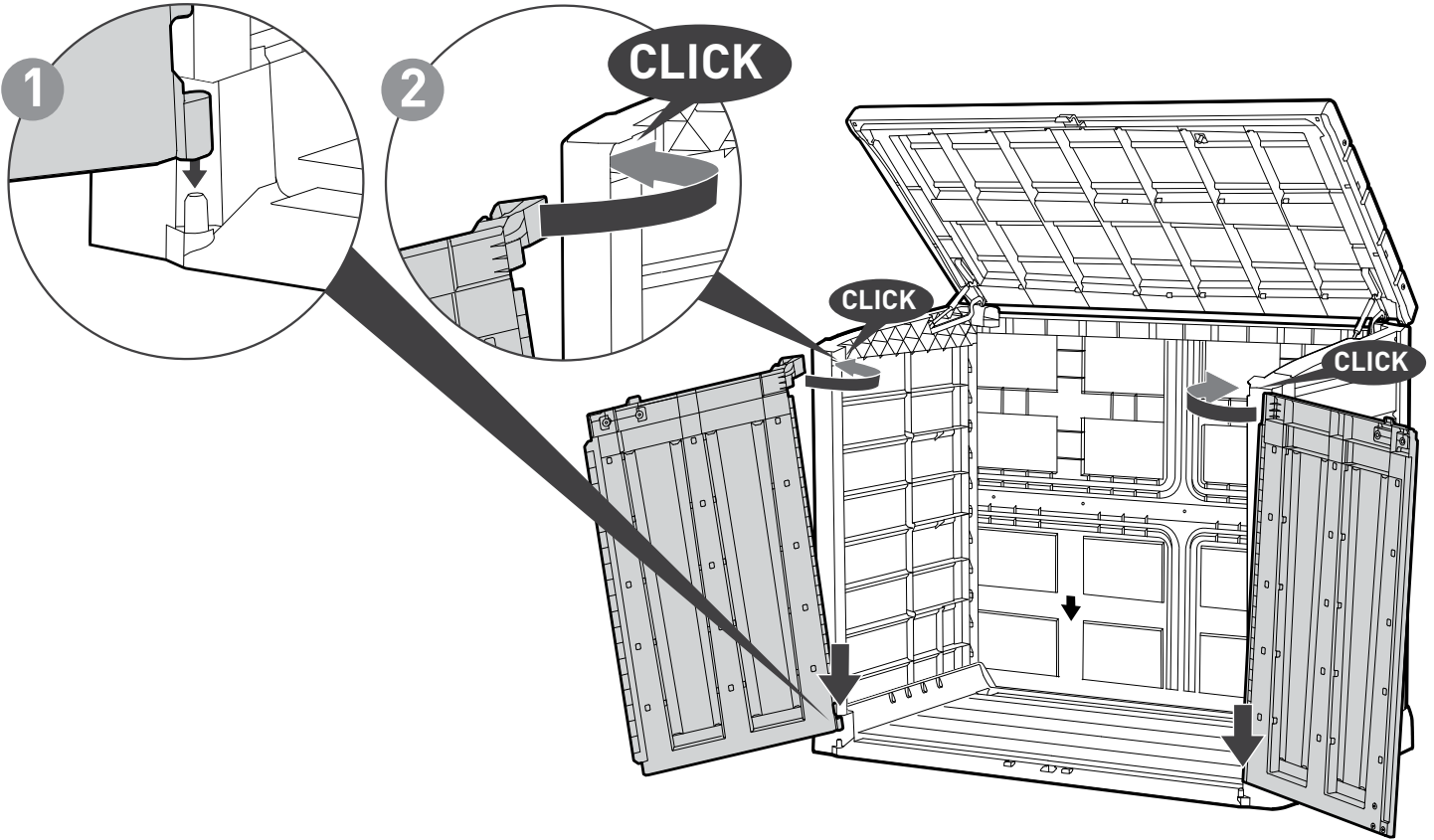

16

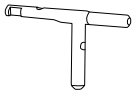

wLHD (x1)

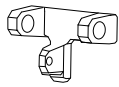

wLBP (x1)

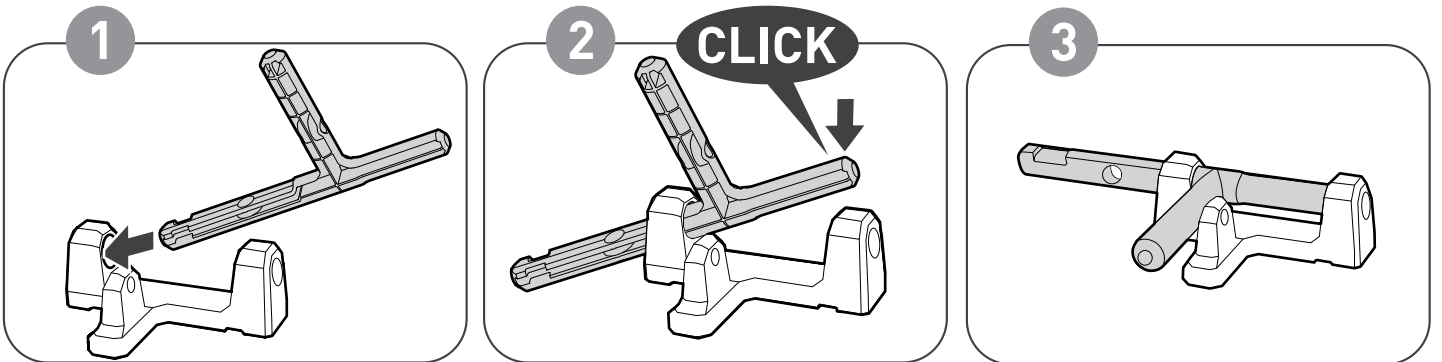

17

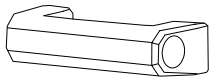

WLGN (x1)

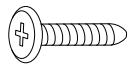

s26b (x4)

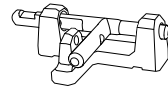

WLHD & WLBP (x1)

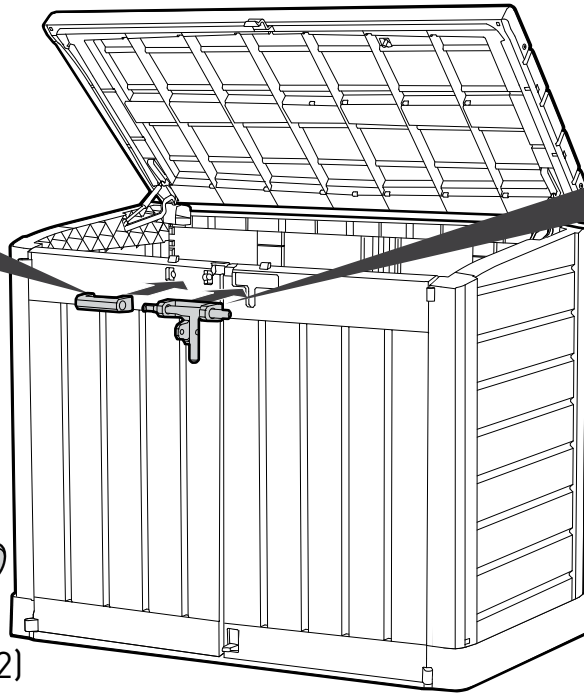
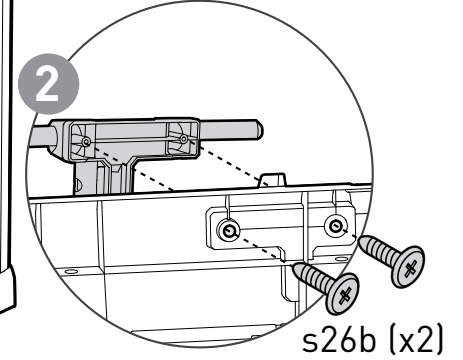
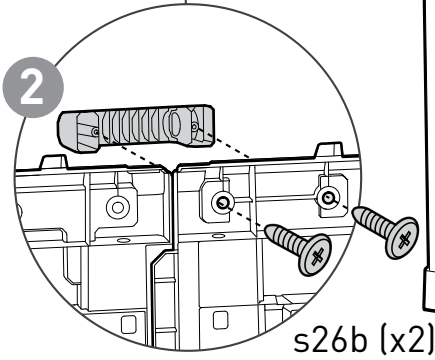
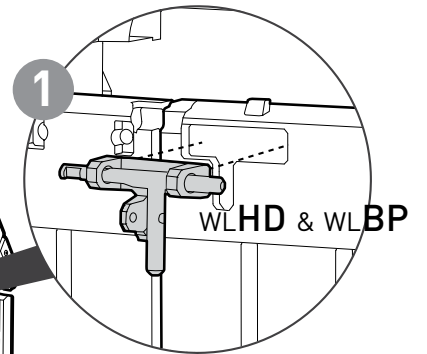
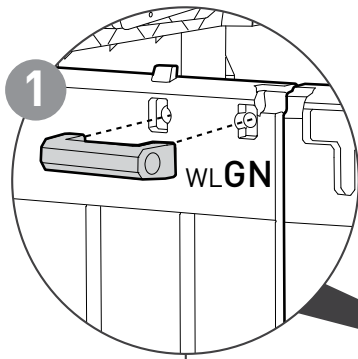

A OPTION | 옵션



WLCO (x2)



WLCC (x2)



WLCN (x2)



s26b (x2)

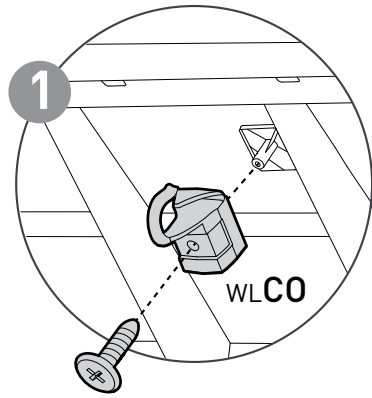
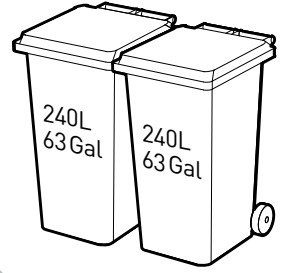

1

WLCO

s26b (x2)

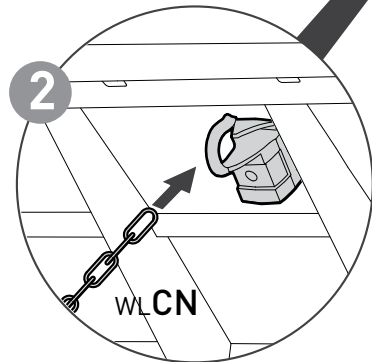

2

WLCN

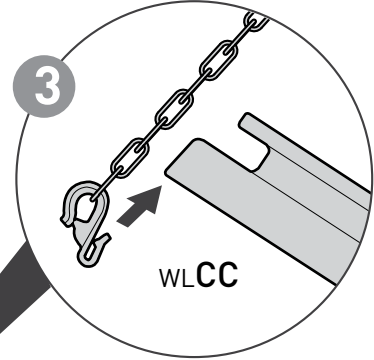

3

WLCC

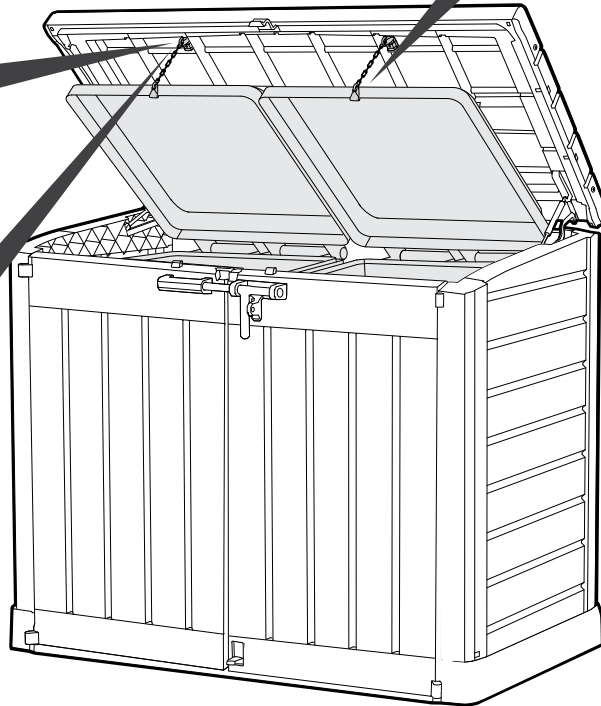

B

OPTION | 옵션

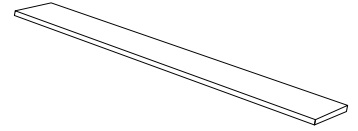

Shelves | 선반

It is optional to purchase a wooden plank and use it as a shelf.

나무판을 구매하여 선반으로 사용하는 것은 선택 사항입니다.

선반이 필요한 경우, 아래 사이즈로 재단하여 사용하십시오.

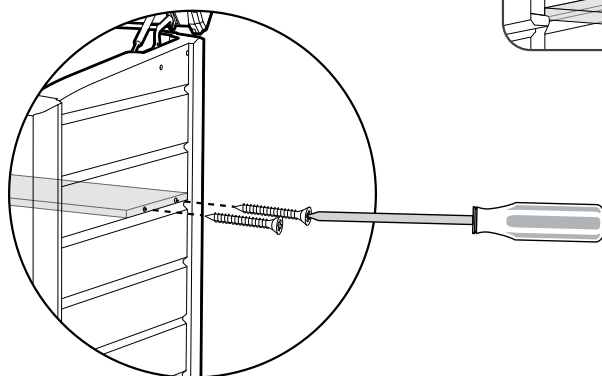
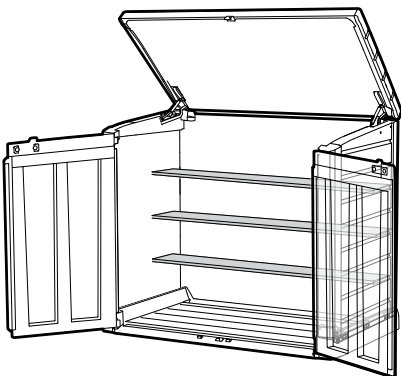
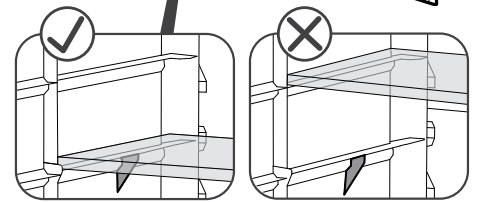
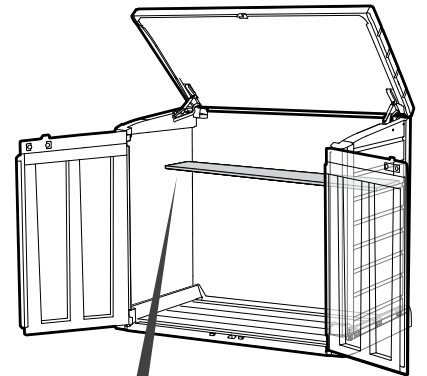
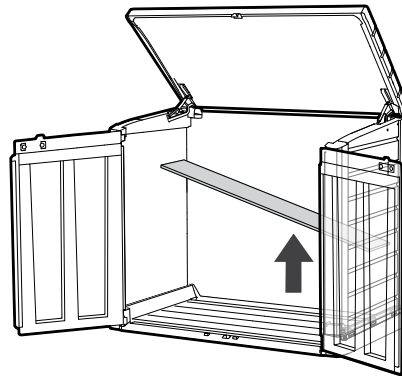
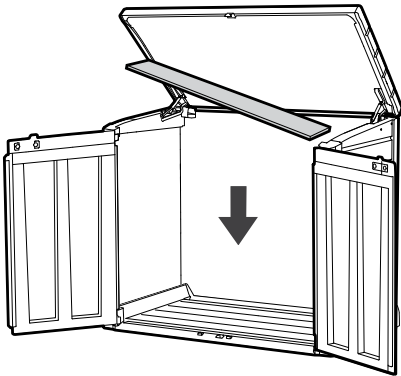
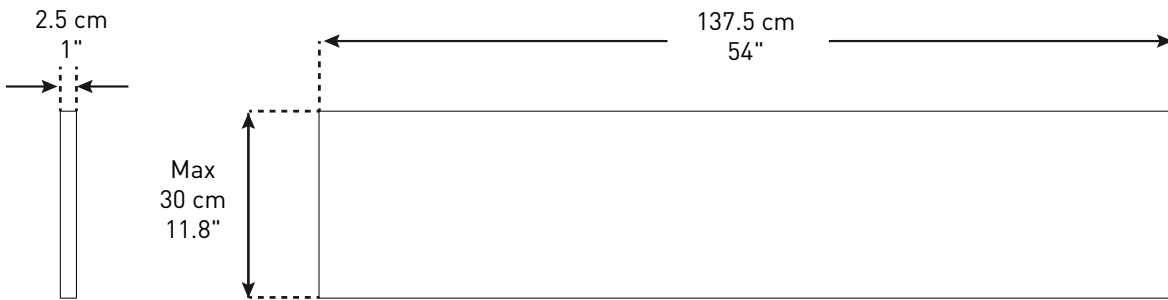

Max 20kg/per shelf 선반 당 최대 하중 : 20kg

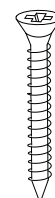

not included

나사는 포함되어 있지 않습니다.

C

OPTION | 옵션

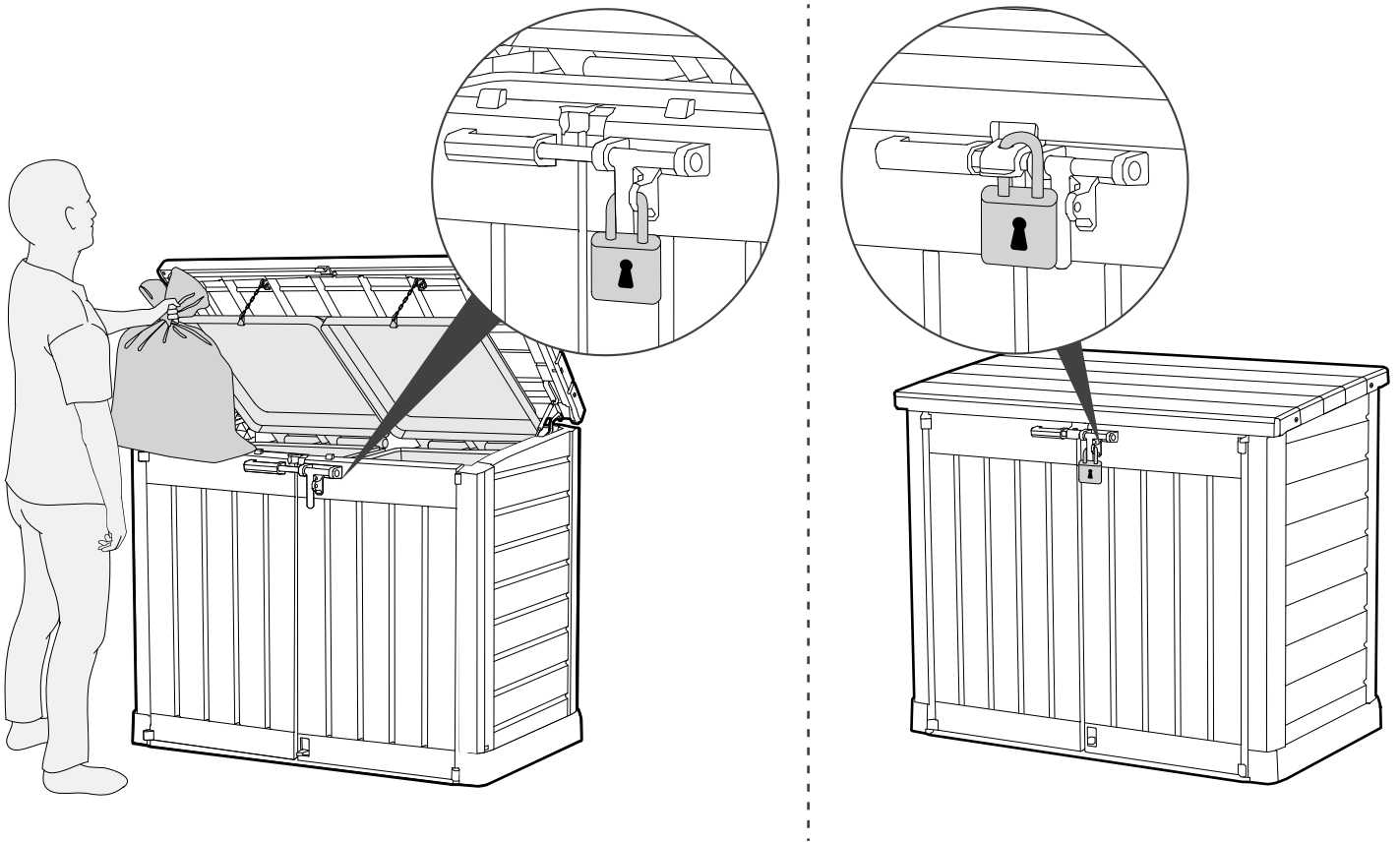

D

OPTION | 옵션

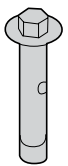

not included
나사는 포함되어 있지 않습니다.

- Secure shed to loor
- 창고를 바닥에 고정하십시오.

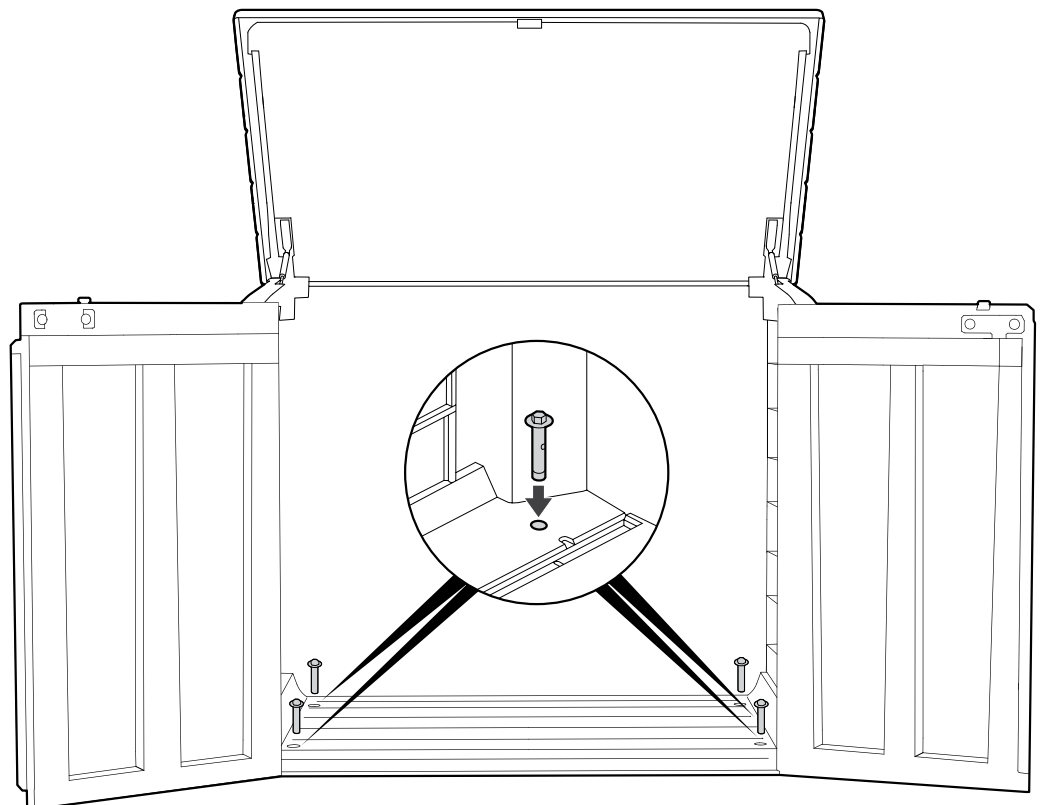

CARE AND SAFETY GUIDELINES

- The shed is intended for storage purposes only. It is not designed for habitation.
- It is strongly recommended to secure the shed to an immovable object or anchor to the ground by drilling holes in the shed floor (at the pre-marked locations) and inserting proper screws into the ground (screws are not included).
- Do not attempt assembly on windy or cold days.
- Periodically check the shed to ensure that it is stable and that the site is level.
- Be careful when handling parts with steel edges.
- When assembling or handling the shed, use only those tools listed in the user manual.
- Always wear work gloves, safety goggles and long sleeves when assembling or performing any maintenance on your shed.
- Avoid using a lawnmower or mechanical scythe near the shed.
- Wear safety goggles and always follow the manufacturer's instructions when using power tools.
- Wash the shed with a garden hose or a mild detergent solution. Do not use a stiff brush or abrasive cleaners, including degreasers and oil- or acetone-based cleaning materials, as these may stain or damage the shed.
- Do not store hot items, such as recently used grills and blowtorches, and volatile chemicals in the shed.
- Avoid placing heavy items against the walls, as this may cause distortion.
- Keep the roof clear of accumulated snow and leaves. Large amounts of snow on the roof can damage the shed, making it unsafe to enter.
- Wind direction is an important factor to consider when determining the location of the shed. Reduce exposure to the wind, in general, and of the door side in particular. Keep doors closed and locked when the shed is not in use to prevent wind damage.
- Do not stand on the roof.
- Consult your local authorities to check if permits are required to erect the shed.

조립, 관리 및 안전에 관한 주의사항

- 창고는 반드시 물건 보관용으로 사용하시고 주거용으로 사용하지 마십시오.
- 창고를 움직이지 않는 물체에 고정시키거나 (창고 바닥에 표시되어 있는 부분을 뚫어)나사를 이용해 땅에 박아 고정할 것을 권장합니다. (나사는 포함되어 있지 않습니다.)
- 바람이 불거나 비가 오는 날, 추운 날에는 조립하지 마십시오.
- 주기적으로 창고의 조립 상태나 설치 장소의 지면 상태를 확인해 주십시오.
- 부품의 모서리가 날카로우니 주의를 기울여 작업하십시오.
- 창고를 조립할 때에는 조립설명서에 나온 도구를 사용하십시오.
- 안전을 위해 항상 장갑, 고글, 긴소매 옷을 착용하십시오.
- 창고 주변에서 잔디 깎기나 낫을 사용할 경우 주의하십시오.
- 청소할 때에는 물이나 연한 세제를 사용하고 뿔뿔한 솔, 연마용 도구, 기름 종류의 재료는 사용하지 마십시오.
- 방금 사용한 그릴, 토치 같은 뜨거운 물건이나 휘발성 제품은 창고에 보관하지 마십시오.
- 무거운 물건을 창고 벽에 기대어 놓으면 창고가 손상될 수 있습니다.
- 사람이 다치거나 창고가 손상될 수 있으니 지붕에 쌓인 눈이나 낙엽들은 바로바로 치워 주십시오. • 창고 위치는 바람의 영향을 최대한 받지 않는 곳으로 결정하시고 항상 문단속을 철저히 하고 자물쇠도 설치해 주십시오.
- 지붕에 올라가지 마시고 물건도 올려놓지 마십시오.
- 창고 설치 전에 반드시 해당 공공기관으로 문의하시고 별도의 샵지를 참고해 주십시오. 더 궁금한 사항이 있는 분들은 고객센터로 연락 주십시오.
- 지상에 설치할 경우 해당 공공기관에 신고를 해야 합니다.
- 농막의 경우도 농지 전용 절차 없이 설치 가능하나 농업 경영에 이용하는 토지에 설치하는 시설일 것,
- 주거 목적이 아닌 농기자재 및 농약 등의 보관, 작업 중 휴식 및 간이 취사 시설일 것,
- 전기/수도/가스 등 간선 공급 시설을 요하지 않을 것 등의 요건을 갖추어야 하며 역시 신고를 해야 합니다.
- 옥상의 경우 어떠한 가설 건축물이든지 반드시 허가를 받아야 합니다.
- 제품의 재질이 합성수지이므로 허가 가능 재질인지 설치 전 꼭 해당 공공기관에 문의하시기 바랍니다.
- 각 지역의 특성상 유권 해석이 상이하기 때문에 법적으로 더 자세한 내용을 알고 싶으시면
- 설치전에 반드시 해당 공공기관으로 문의하여 문제가 발생하지 않도록 하시기 바랍니다.

2-YEAR LIMITED WARRANTY

Your Keter shed ("the Product") was manufactured from high-quality, recyclable materials under rigorous control and supervision. Should a problem occur with the Product, please address your claim to Keter customer service on our website (www.keter.com) or by phone. This warranty covers product failure resulting from defects in manufacturing or materials for a period of 2 years from the date of original retail purchase. (The term "defects" is defined as imperfections that impair the use of the Product). This warranty does not cover defects resulting from normal wear and tear, including, but not limited to, scuffing, scratches or fractures caused during use, discoloration or fading, rusting, unreasonable use, abuse, negligence, alterations, painting, moving, transporting or relocating the Product, "acts of Nature" , including, but not limited to, hail, any type of storm, flood and fire, and consequential or incidental damages. Assembly and handling not in accordance with the recommendations, guidelines and restrictions as described in the Product's user manual, and usage for commercial or public applications, will void this warranty. Keter is not responsible for any damage incurred by third parties or damage to or loss of objects inside or near the shed.

품질보증설명

KETER의 조립식 창고는 엄격한 관리 아래 고품질의 재료와 재활용이 가능한 재료로 제작하고 있습니다.

제품에 문제가 발생한 경우 웹사이트 고객센터에 접속하거나 연락하여 클레임을 해결하십시오.

제품에 결함이 있을 경우 구매일로부터 2년 동안 품질보증에 적용됩니다. (결함은 제품 기능이 저하되는 것을 의미합니다).

사용 중에 발생한 마모, 찢김, 구멍, 흠집, 균열, 변색, 색바래, 녹, 오남용, 과실, 개조, 도장, 이동, 제품의 운반 및 재 조립을 포함한 우박, 태풍, 강풍, 홍수, 화재, 대설 등의 자연 재해로 인한 문제에 대해서는 품질 보증을 하지 않습니다.

조립 설명서대로 조립하지 않았거나 주의사항 무시, 상업적 용도 혹은 공적인 용도로 사용할 경우에도 품질보증을 하지 않습니다.

제 3자에 의한 피해나 창고 내 외부에 있는 물건의 분실에 대해서도 KETER는 책임지지 않습니다.



For assistance with assembly, or to request replacement parts, log onto our website or call Customer Service.

DO NOT RETURN THE PRODUCT TO THE STORE.

조립시에 궁금한 점이나 부품에 문제가 있어 교환이 필요하신 분들은 고객센터로 연락주시기 바랍니다.

고객 센터

TEL.031-767-2492

FAX.031-717-2497

E-mail.info@keter.co.kr

월 - 금 10:00am - 5:30pm

WWW.KETER.COM